**UNITED STATES
SECURITIES AND EXCHANGE COMMISSION**
Washington, D.C. 20549

FORM 20-F

- REGISTRATION STATEMENT PURSUANT TO SECTION 12(b) OR (g) OF THE SECURITIES EXCHANGE ACT OF 1934**

OR

- ANNUAL REPORT PURSUANT TO SECTION 13 OR 15(d) OF THE SECURITIES EXCHANGE ACT OF 1934**

For the fiscal year ended December 31, 2006

OR

- TRANSITION REPORT PURSUANT TO SECTION 13 or 15(d) OF THE SECURITIES EXCHANGE ACT OF 1934**

For the transition period from _____ to _____

OR

- SHELL COMPANY REPORT PURSUANT TO SECTION 13 OR 15 (d) OF THE SECURITIES EXCHANGE ACT OF 1934**

Commission file number 1-12158

中国石化上海石油化工股份有限公司

(Exact name of Registrant as specified in its charter)

Sinopec Shanghai Petrochemical Company Limited
(Translation of Registrant's name into English)

The People's Republic of China
(Jurisdiction of incorporation or organization)

No. 48 Jinyi Road, Jinshan District, Shanghai, PRC 200540
(Address of principal executive offices)

Securities registered or to be registered pursuant to Section 12(b) of the Act.

Title of each class	Name of each exchange on which registered
American Depositary Shares, each representing 100 Class H Ordinary Shares, par value RMB1.00 per Share Class H Ordinary Shares, par value RMB1.00 per Share	New York Stock Exchange The Stock Exchange of Hong Kong Limited

Securities registered or to be registered pursuant to Section 12(g) of the Act.

None
(Title of Class)

Securities for which there is a reporting obligation pursuant to Section 15(d) of the Act.

None
(Title of Class)

Indicate the number of outstanding shares of each of the issuer's classes of capital or common stock as of the close of the period covered by the annual report.

2,330,000,000 H Shares, par value RMB1.00 per Share
4,870,000,000 Domestic Shares, par value RMB1.00 per Share

Indicate by check mark if the registrant is a well-known seasoned issuer, as defined in Rule 405 of the Securities Act. Yes No

If this report is an annual or transition report, indicate by check mark if the registrant is not required to file reports pursuant to Section 13 or (15) (d) of the Securities Exchange Act of 1934. Yes No

Indicate by check mark whether the registrant (1) has filed all reports required to be filed by Section 13 or 15(d) of the Securities Exchange Act of 1934 during the preceding 12 months (or for such shorter period that the registrant was required to file such reports), and (2) has been subject to such filing requirements for the past 90 days. Yes No

Indicate by check mark whether the registrant is a large accelerated filer, an accelerated filer, or a non-accelerated filer. See definition of "accelerated filer and large accelerated filer" in Rule 12b-2 of the Exchange Act. (Check one):

Large Accelerated Filer Accelerated Filer Non-Accelerated Filer

Indicate by check mark which financial statement item the registrant has elected to follow. Item 17 Item 18

If this is an annual report, indicate by check mark whether the registrant is a shell company (as defined in Rule 12b-2 of the Exchange Act). Yes No

	<u>CAUTIONARY STATEMENT REGARDING FORWARD-LOOKING STATEMENTS</u>	II
	<u>EXCHANGE RATES</u>	II
	<u>CERTAIN TERMS AND CONVENTIONS</u>	II
	<u>PART I</u>	1
ITEM 1.	<u>IDENTITY OF DIRECTORS, SENIOR MANAGEMENT AND ADVISORS.</u>	1
ITEM 2.	<u>OFFER STATISTICS AND EXPECTED TIMETABLE.</u>	1
ITEM 3.	<u>KEY INFORMATION.</u>	1
ITEM 4.	<u>INFORMATION ON THE COMPANY.</u>	12
ITEM 4A.	<u>UNRESOLVED STAFF COMMENTS</u>	36
ITEM 5.	<u>OPERATING AND FINANCIAL REVIEW AND PROSPECTS</u>	36
ITEM 6.	<u>DIRECTORS, SENIOR MANAGEMENT AND EMPLOYEES.</u>	53
ITEM 7.	<u>MAJOR SHAREHOLDERS AND RELATED PARTY TRANSACTIONS.</u>	63
ITEM 8.	<u>FINANCIAL INFORMATION.</u>	67
ITEM 9.	<u>THE OFFER AND LISTING.</u>	68
ITEM 10.	<u>ADDITIONAL INFORMATION.</u>	70
ITEM 11.	<u>QUANTITATIVE AND QUALITATIVE DISCLOSURES ABOUT MARKET RISK.</u>	94
ITEM 12.	<u>DESCRIPTION OF SECURITIES OTHER THAN EQUITY SECURITIES.</u>	96
	<u>PART II</u>	96
ITEM 13.	<u>DEFAULTS, DIVIDEND ARREARAGES AND DELINQUENCIES.</u>	96
ITEM 14.	<u>MATERIAL MODIFICATIONS TO THE RIGHTS OF SECURITY HOLDERS AND USE OF PROCEEDS.</u>	96
ITEM 15.	<u>CONTROLS AND PROCEDURES</u>	96
ITEM 16A.	<u>AUDIT COMMITTEE FINANCIAL EXPERT</u>	99
ITEM 16B.	<u>CODE OF ETHICS</u>	99
ITEM 16C.	<u>PRINCIPAL ACCOUNTANT FEES AND SERVICES</u>	99
ITEM 16D.	<u>EXEMPTIONS FROM THE LISTING STANDARDS FOR AUDIT COMMITTEES.</u>	100
ITEM 16E.	<u>PURCHASES OF EQUITY SECURITIES BY THE ISSUER AND AFFILIATED PURCHASERS.</u>	100

<u>PART III</u>		100
ITEM 17.	<u>FINANCIAL STATEMENTS.</u>	100
ITEM 18.	<u>FINANCIAL STATEMENTS.</u>	100
ITEM 19.	<u>EXHIBITS</u>	101

CAUTIONARY STATEMENT REGARDING FORWARD-LOOKING STATEMENTS

Information in this Annual Report which does not relate to historical financial information may be deemed to constitute forward-looking statements. The words or phrases “may”, “will”, “expect”, “anticipate”, “plan”, “will likely result”, “estimate”, “project”, “believe”, “intends to” or similar expressions identify “forward-looking statements” within the meaning of the Private Securities Litigation Reform Act of 1995. These statements are subject to risks and uncertainties that could cause actual results to differ materially from historical results and those presently anticipated or projected in the forward-looking statements. We caution readers not to place undue reliance on any forward looking statements, which speak only as of the date made. We undertake no obligations to update any forward-looking statements to reflect events and circumstances after the date on which the statements are made or reflect the occurrence of unanticipated events. Among the factors that could cause our actual results in the future to differ materially from the forward-looking statements are crude oil allocations, effects of the macroeconomic policy of The People’s Republic of China and government control of currency conversion and the prices of refined oil products.

EXCHANGE RATES

Unless otherwise specified, references in this Annual Report to “US dollars” or “US\$” are to United States dollars, references to “HK dollars” or “HK\$” are to Hong Kong dollars and references to “Renminbi” or “RMB” are to Renminbi yuan, the legal tender currency of the PRC.

We publish our financial statements in Renminbi. Unless otherwise indicated, all translations from Renminbi to US dollars have been made at a rate of RMB7.8041 to US\$1.00, the noon buying rate as certified for customs purposes by the Federal Reserve Bank of New York on December 29, 2006. We do not represent that Renminbi or US dollar amounts could be converted into US dollars or Renminbi, as the case may be, at any particular rate.

CERTAIN TERMS AND CONVENTIONS

References to “we” or “us” are references to Sinopec Shanghai Petrochemical Company Limited and our subsidiaries, unless the context requires otherwise. Before our formation, these references relate to the petrochemical businesses carried on by Shanghai Petrochemical Complex.

References to “China” or the “PRC” are references to The People’s Republic of China which, for the purpose of this Annual Report and for geographical reference only, excludes Hong Kong, Macau and Taiwan.

References to our “A Shares” are references to 720,000,000 of our domestic shares, par value RMB1.00 per share, which are ordinary shares subscribed for and traded exclusively on the Shanghai Stock Exchange by and between Chinese investors.

References to “ADSs” are references to our American Depositary Shares, which are listed and traded on the New York Stock Exchange. Each ADS represents 100 H Shares.

References to our “domestic shares” are references to all of our domestic shares, par value RMB1.00 per share, which are ordinary shares held by Chinese investors.

References to our “H Shares” are references to our overseas-listed foreign ordinary shares, par value RMB1.00 per share, which are listed and traded on the Stock Exchange of Hong Kong Limited (“HKSE”) under the number “338”.

“Rated Capacity” is the output capacity of a given production unit or, where appropriate, the throughput capacity, calculated by estimating the number of days in a year that the production unit is expected to operate, including downtime for regular maintenance, and multiplying that number by an amount equal to the unit’s optimal daily output or throughput, as the case may be.

All references to “tons” are to metric tons.

Unless otherwise noted, references to sales volume are to sales to entities other than us or our divisions and subsidiaries.

PART I

ITEM 1. ID ENTITY OF DIRECTORS, SENIOR MANAGEMENT AND ADVISORS.

Not applicable.

ITEM 2. OFFER STATISTICS AND EXPECTED TIMETABLE.

Not applicable.

ITEM 3. KEY INFORMATION.

A. Selected Financial Data.

Our statements of operations and cash flow data for each of the years ended December 31, 2004, 2005 and 2006 and the balance sheet data as of December 31, 2005 and 2006 are derived from our consolidated financial statements included in Item 18. Financial Statements. Our statements of operations and cash flow data for the years ended December 31, 2002 and 2003 and the balance sheet data as of December 31, 2002, 2003 and 2004 are derived from consolidated financial statements not included in this Annual Report. Our selected consolidated financial data should be read in conjunction with our consolidated financial statements, and the notes thereto, and Item 5. Operating and Financial Review and Prospects. Our consolidated financial statements have been prepared in accordance with International Financial Reporting Standards (“IFRS”). IFRS vary in certain significant respects from accounting principles generally accepted in the United States of America (“U.S. GAAP”). Information relating to the nature and effect of such differences is presented in Item 18. Financial Statements – Consolidated Financial Statements – Note 34.

Selected Consolidated Financial Data
(in thousands, except per share and per ADS data)

	Years Ended December 31,				
	2002 (RMB)	2003 (RMB)	2004 (RMB)	2005 (RMB)	2006 (RMB)
STATEMENTS OF INCOME DATA					
Amounts in accordance with IFRS:					
Net sales:					
Synthetic fibers	3,374,252	4,092,590	4,751,773	4,763,993	4,711,667
Resins and plastics	6,440,673	8,864,266	12,085,967	13,958,329	15,753,304
Intermediate petrochemicals	2,555,035	3,851,333	5,896,580	6,555,953	6,775,721
Petroleum products	7,991,243	10,329,149	13,101,919	17,954,954	19,387,666
All others	1,361,766	1,805,345	2,827,820	1,956,985	3,289,765
Other income	—	—	—	632,820	282,142
Cost of sales	19,853,928	26,396,224	33,223,604	42,887,742	49,182,232
Income from operations	1,429,629	2,006,403	5,025,152	2,527,960	552,907
Net financing costs	400,656	392,021	292,008	179,398	165,389
Income before income tax	1,045,038	1,590,365	4,696,229	2,287,594	964,200
Net income attributable to equity shareholders of the Company	916,365	1,401,690	3,971,103	1,850,449	844,407
Net income attributable to minority interests	44,179	43,610	88,065	70,845	66,555
Basic earnings per share(a)	0.13	0.20	0.55	0.26	0.12
Basic earnings per ADS(a)	12.73	19.47	55.15	25.70	11.73

	Years Ended December 31,				
	2002 (RMB)	2003 (RMB)	2004 (RMB)	2005 (RMB)	2006 (RMB)
Amounts in accordance with US GAAP					
Cost of sales	19,665,176	26,207,472	33,069,429	42,871,861	49,166,351
Profit from operations	1,628,525	2,221,729	5,191,926	2,543,841	568,788
Income before income taxes and minority interests	1,264,930	1,812,736	4,899,844	2,309,871	970,808
Taxation	115,956	174,435	665,714	369,642	54,229
Cumulative effect of adopting SFAS No.142	19,828	—	—	—	—
Net income	1,124,623	1,568,439	4,146,065	1,869,384	850,024
Basic earnings per share(a)	0.16	0.22	0.58	0.26	0.12
Basic earnings per ADS(a)	15.62	21.78	57.58	25.96	11.81
Reconciliation to net income in accordance with US GAAP:					
Net Income attributable to equity shareholders of the Company under IFRS	916,365	1,401,690	3,971,103	1,850,449	844,407
Adjustments to net income attributable to equity shareholders of the Company under IFRS:					
Foreign exchange gains and losses	37,054	37,054	2,473	—	—
Capitalization of property, plant and equipment	21,703	21,703	21,707	—	—
Depreciation charge on revalued property, plant and equipment	129,995	129,995	129,995	15,881	15,881
Capitalized interest on investment in associates, net of amortization effect	20,996	7,045	36,841	6,396	(9,273)
Goodwill and negative goodwill amortization	10,144	322	13,448	—	—
Cumulative effect of adopting SFAS No.142	19,828	—	—	—	—
Deferred tax effect of the above adjustments	(31,462)	(29,370)	(28,653)	(3,342)	(991)
Net income under US GAAP	1,124,623	1,568,439	4,146,065	1,869,384	850,024
Basic earnings per share(a)	0.16	0.22	0.58	0.26	0.12
Basic earnings per ADS(a)	15.62	21.78	57.58	25.96	11.81
CASH FLOW DATA					
Amounts in accordance with IFRS					
Net cash flow generated from operating activities	1,798,320	2,276,957	4,589,711	3,943,578	1,696,615
Depreciation	1,585,823	1,850,013	1,794,120	1,705,060	1,823,668
Capital expenditures	2,404,293	1,284,868	2,205,957	1,142,927	2,008,779
Net proceeds from issuance of corporate bonds	—	—	—	—	2,977,800
Proceeds from loans	7,575,168	7,490,040	5,214,936	9,836,199	13,939,126
Repayment of loans	6,551,874	7,619,254	6,981,696	11,393,941	15,910,127
Amounts in accordance with US GAAP					
Depreciation	1,288,779	1,552,969	1,531,657	1,580,887	1,807,787

(a) The calculation of earnings per share is based on the weighted average number of shares outstanding during the year of 7,200,000,000 in each of 2006, 2005, 2004, 2003, and 2002, respectively. Earnings per ADS is calculated on the basis that one ADS is equivalent to 100 shares.

	Years Ended December 31,				
	2002 (RMB)	2003 (RMB)	2004 (RMB)	2005 (RMB)	2006 (RMB)
BALANCE SHEET DATA					
Amounts in accordance with IFRS:					
Property, plant and equipment, net	15,809,493	16,020,104	15,206,325	14,651,167	13,359,862
Total assets	26,085,919	27,101,481	28,276,601	26,810,371	27,406,060
Short term debt(a)	4,002,315	5,574,729	5,000,305	3,926,742	4,270,337
Long term debt (excluding current portion)	4,590,891	3,206,848	2,014,614	1,477,261	1,063,654
Total equity attributable to equity shareholders of the Company	13,980,196	15,021,886	18,416,989	18,829,987	18,976,343
Amounts in accordance with US GAAP					
Property, plant and equipment, net	15,403,045	15,802,408	15,142,804	14,603,527	13,328,103
Total assets	25,808,928	26,991,239	28,341,321	26,891,478	27,505,732
Net shareholders' equity	13,703,205	14,911,644	18,481,709	18,911,094	19,063,067

(a) Including corporate bonds and current portion of long term debt.

Dividends

The following table sets forth certain information concerning the dividends since January 1, 1994:

Dividend Period	Dividend per Share
January 1, 1994-June 30, 1994	RMB0.04 (US\$0.0048)
July 1, 1994-December 31, 1994	RMB0.085 (US\$0.0103)
January 1, 1995-June 30, 1995	RMB0.04 (US\$0.0048)
July 1, 1995-December 31, 1995	RMB0.09 (US\$0.0109)
January 1, 1996-June 30, 1996	RMB0.04 (US\$0.0048)
July 1, 1996-December 31, 1996	RMB0.08 (US\$0.0097)
January 1, 1997-December 31, 1997	RMB0.06 (US\$0.0072)
January 1, 1998-December 31, 1998	RMB0.03 (US\$0.0036)
January 1, 1999-December 31, 1999	RMB0.05 (US\$0.0060)
January 1, 2000-December 31, 2000	RMB0.06 (US\$0.0072)
January 1, 2001-December 31, 2001	No dividend
January 1, 2002-December 31, 2002	RMB0.05 (US\$0.0060)
January 1, 2003-December 31, 2003	RMB0.08 (US\$0.0097)
January 1, 2004-December 31, 2004	RMB0.20 (US\$0.0242)
January 1, 2005-December 31, 2005	RMB0.10 (US\$0.0124)
January 1, 2006-December 31, 2006	RMB0.04 (US\$0.0051)

See also Item 8.A. Financial Information – Consolidated Statements and Other Financial Information – Dividend Policy.

Exchange Rates

The Chinese government controls its foreign currency reserves in part through direct regulation of the conversion of Renminbi into foreign exchange and through restrictions on foreign trade. See Item 10.D. Additional Information – Exchange Controls.

The following table sets forth information concerning exchange rates between Renminbi and US dollars for the periods indicated:

Period	Noon Buying Rates (RMB/US\$)			
	Period End	Average ⁽¹⁾	High	Low
2002	8.2800	8.2772	8.2800	8.2669
2003	8.2767	8.2771	8.2800	8.2765
2004	8.2765	8.2768	8.2774	8.2764
2005	8.0702	8.1828	8.2765	8.0702
2006	7.8041	7.9579	8.0702	7.8041
December 2006	7.8041	—	7.8350	7.8041
January 2007	7.7714	—	7.8127	7.7705
February 2007	7.7410	—	7.7632	7.7410
March 2007	7.7232	—	7.7454	7.7232
April 2007	7.7090	—	7.7345	7.7090
May 2007	7.6516	—	7.7065	7.6490
Latest Practicable Date, June 15, 2007	7.6245	—	—	—

Source: The noon buying rate in New York for cable transfers payable in foreign currencies as certified for customs purposes by the Federal Reserve Bank of New York.

Note: (1) Determined by averaging the rates on the last business day of each month during the respective period.

B. Capitalization and Indebtedness.

Not applicable.

C. Reasons for the Offer and Use of Proceeds.

Not applicable.

D. Risk Factors.

Some of our major products are subject to government price controls, and we are not able to pass on all cost increases from rising crude oil prices through higher product prices.

We consume large amounts of crude oil to manufacture our products. While we try to match crude oil cost increases with sales price increases, our ability to pass on cost increases to our customers is dependent on market conditions and government regulations, particularly government regulation with respect to the price of crude oil and certain of our products. In particular, three types of our petroleum products, gasoline, diesel and jet fuel, and certain other of our major products are subject to government price controls. In 2004, 2005 and 2006, approximately 57%, 58% and 53.96% of our net sales were from products subject to price controls. In 2006, our production costs increased significantly due to the continued price increase of crude oil on the international market. Because the cost of crude oil accounted for 67.72% of our total cost of sales in 2006, and the average processing costs for crude oil increased by 17.84% compared to 2005, which was much higher than the price increases of our products, our profit margin in 2006 decreased significantly. Moreover, the Chinese government controls the distribution of many petroleum products in China. Some of our petroleum products must be sold to designated customers such as the subsidiaries of China Petrochemical Corporation, and we cannot freely sell our petroleum products to take advantage of opportunities for higher prices. Therefore, in periods of high crude oil prices, such as now, we would not be able to fully cover increases in crude oil prices by increases in the sale prices of our products, which has had and will continue to have a material adverse effect on our financial condition, results of operations or cash flows.

Our operations may be adversely affected by the cyclical nature of the petroleum and petrochemical market and by the volatility of prices of crude oil and refined oil products.

Most of our revenues are attributable to petrochemical products, which have historically been cyclical and sensitive to the availability and price of feedstocks and general economic conditions. Markets for many of our products are sensitive to changes in industry capacity and output levels, cyclical changes in regional and global economic conditions, the price and availability of substitute products and changes in consumer demand, which from time to time have had a significant impact on product prices in the regional and global markets. Historically, the markets for these products have experienced alternating periods of tight supply, causing prices and margins to increase, followed by periods of capacity additions, possibly resulting in oversupply and declining prices and margins. As tariffs and other import restrictions are reduced and the control of product allocation and pricing is relaxed in China, the markets for many of our products have become increasingly subject to the cyclical nature of regional and global markets. Historically, international prices of crude oil have fluctuated widely due to many other factors that are beyond our control. We cannot assure you that future growth in demand for our products will be sufficient to alleviate any existing or future conditions of excess industry capacity or that such conditions will not be sustained or further aggravated by anticipated or unanticipated capacity additions or other events. In addition, we expect that the volatility and uncertainty of the prices of crude oil and petrochemical products will continue. Increasing crude oil prices and declines in prices of petrochemical products may adversely affect our business and results of operations and financial condition.

Our development plans have significant capital expenditure and financing requirements, which are subject to a number of risks and uncertainties.

The petrochemical business is a capital intensive business. Our ability to maintain and increase our revenues, net income and cash flows depends upon continued capital spending. Our current business strategy contemplates capital expenditures for 2007 of approximately RMB 2.5 billion (US\$320.16 million), which will be provided through financing activities and use of our own capital. Our actual capital expenditures may vary significantly from these planned amounts due to our ability to generate sufficient cash flows from operations, investments and other factors that may be beyond our control. In addition, there can be no assurance as to whether, or at what cost, our capital projects will be completed or the success of these projects if completed.

As of March 31, 2007, we had aggregate outstanding indebtedness of approximately RMB4,967 million (US\$636.09 million). China Petroleum & Chemical Corporation (“Sinopec Corp”), our controlling shareholder, did not provide any guarantee or credit support for our debt for the year ended December 31, 2006 and for the three-month period ended March 31, 2007.

Our ability to obtain external financing in the future is subject to a variety of uncertainties, including:

- our future results of operations, financial condition and cash flows;
- the condition of the economy in China and the markets for our products;
- the cost of financing and the condition of financial markets; and

-
- the issuance of relevant government approvals and other project risks associated with the development of infrastructure in China.

Our failure to obtain sufficient funding for our operations or development plans could adversely affect our business, results of operations and financial condition.

We could face increased competition.

Our principal market, Eastern China, which comprises of Shanghai, Jiangsu, Zhejiang, Anhui and Jiangxi, has enjoyed stronger economic growth and a higher demand for petrochemical products than other regions of China. As a result, we believe that competitors will try to expand their sales and build up their distribution networks in our principal market. We believe this trend will continue and probably accelerate. Increased competition may have a material adverse effect on our financial condition and results of operations.

Related party transactions; non-competition; conflicts of interests.

We have engaged from time to time and will continue to engage in a variety of transactions with Sinopec Corp and China Petrochemical Corporation, the controlling shareholder of Sinopec Corp, and their various subsidiaries or affiliates who provide a number of services to us, including sales and marketing, educational and community services. Our transactions with these companies are governed by a number of service and other contracts, the terms of which were negotiated on an arm's length basis. Our business and results of operations could be adversely affected if Sinopec Corp refuses to engage in such transactions or if it seeks to amend our contracts with it in a way adverse to us. In addition, Sinopec Corp has interests in businesses which compete or are likely to compete, either directly or indirectly, with our businesses. Because Sinopec Corp is our controlling shareholder and its interests may conflict with our own interests, Sinopec Corp may take actions that favor itself over our interests.

We are controlled by Sinopec Corp, whose interests may not be aligned with yours.

As of June 15, 2007, Sinopec Corp owned 55.56% of our shares. Accordingly, it has voting and management control over us, and its interests may be different from your interests and the interests of our other shareholders. Subject to our Articles of Association and applicable laws and regulations, Sinopec Corp will be in a position to cause us to declare dividends, determine the outcome of corporate actions requiring shareholder approval or effect corporate transactions without the approval of the holders of the H shares and ADSs. Any such increase in our dividend payout would reduce funds available for reinvestment in our business and any such actions or transactions could adversely affect us or our minority shareholders. Additionally, Sinopec Corp completed its initial public offering of shares in late 2000. As a public company, Sinopec Corp may experience changes in its own business strategy and policies. Although we are not currently aware of any such changes, they could, in turn, lead Sinopec Corp to change its policies or practices toward us in ways that we cannot predict, with corresponding unpredictable consequences for our business.

Our business operations may be adversely affected by present or future environmental regulations.

We are subject to extensive environmental protection laws and regulations in China. These laws and regulations permit:

- the imposition of fees and penalties for the discharge of waste substances;

-
- the levy of fines and payments for damages for environmental offenses; and
 - the government to close or suspend any facility which fails to comply with orders and require it to correct or stop operations causing environmental damage.

Our production operations produce substantial amounts of waste materials. In addition, our production facilities require operating permits that are subject to renewal, modification and revocation. We believe that our operations substantially comply with all applicable Chinese environmental laws and regulations as they have been previously interpreted and enforced. The Chinese government, however, has moved, and may move further, toward more rigorous enforcement of applicable laws, and toward the adoption of more stringent environmental standards. There can be no assurance that Chinese national or local authorities will not impose additional regulations or apply more rigorous enforcement of such regulations which would require additional expenditures on environmental matters.

Our business may be limited or adversely affected by government regulations.

The central and local Chinese governments continue to exercise a certain degree of control over the petrochemical industry in China by, among other things:

- mandating distribution channels for our petroleum products;
- setting the allocations and pricing of certain resources, products and services;
- assessing taxes and fees payable;
- setting import and export quotas and procedures; and
- setting safety, environmental and quality standards.

As a result, we may face significant constraints on our flexibility and ability to expand our business operations or to maximize our profitability. In the past, we have benefited from favorable regulatory policies that have, for example, reduced the competition we face from illegal imports of petroleum products. Existing policies that favor our industry may change in the future and our business could be adversely affected by any such changes.

Our development plans may require regulatory approval.

We are currently engaged in a number of construction and expansion projects. Most of our projects are subject to governmental review and approval. The timing and cost of completion of these projects will depend on numerous factors, including approvals from relevant government authorities and general economic conditions in China.

While in general we attempt to obtain governmental approval as far in advance as practicable, we may not be able to control the timing and outcome of these governmental reviews and approvals. If any of our important projects required for our future growth are not approved, or not approved on a timely basis, our results of operations and financial condition could be adversely affected.

China's entry into the World Trade Organization, or WTO, may significantly increase foreign competition in our lines of business.

China joined the WTO on December 11, 2001. As part of its membership, China has committed to eliminate some tariff and non-tariff barriers to foreign competition in the domestic petrochemical industry that benefited us in the past. In particular, China:

- has reduced tariffs on imported petrochemicals products that compete with ours to 2% to 14% from 5% to 17%;
- increased levels of permitted foreign investment in the domestic petrochemicals industry, allowing foreign investors to own 100% of a domestic petrochemicals company from December 11, 2004;
- has gradually relaxed restrictions on the import of crude oil by non-state owned companies;
- has granted foreign-owned companies the right to import petrochemical products; and
- has permitted foreign-owned companies to distribute and market petroleum products in both retail and wholesale markets in China.

As a result of these measures, we face increased competition from foreign companies and imports. Overall, we think that China's WTO entry also creates substantial amounts of new investment and business in China, with a potential increase in sales opportunities for us. We do, however, believe that our products have been and will continue generally to be competitive with imported products in the PRC. Tariff reductions, however, could reduce our profit margins or otherwise negatively impact our revenue from certain products, including a small number of significant products. The PRC government may also reduce the tariffs imposed on production equipment that we may import in the future, as well as the restrictions on availability of imported raw materials (such as crude oil) currently enforced by the government. Although we believe that China's accession to the WTO may provide us with opportunities to increase our sales, we cannot be certain of its effect on our business or results of operations. In addition, we believe that major international petrochemical companies are preparing to enter the Chinese market amid industry restructuring on a global basis. Apart from posing direct competition against us in petroleum and petrochemical products, these international companies are characterized by large-scale investments across different sectors, full vertical integration and streamlined organization. We expect that domestic companies will face intense competition from their international counterparts as the China market becomes increasingly internationalized.

Political and economic policies in China could affect our business in unpredictable ways.

The economy of China differs from the economies of most countries belonging to the Organization for Economic Co-operation and Development in a number of respects, including:

- structure;
- level of government involvement;
- level of development;
- level of capital reinvestment;

-
- control of foreign exchange; and
 - allocation of resources.

Before its adoption of reform and open-door policies beginning in 1978, China was primarily a planned economy. Since that time, the Chinese government has been reforming the Chinese economic system, and has also begun reforming the government structure. These reforms have resulted in significant economic growth and social progress. Although the Chinese government still owns a significant portion of the productive assets in China, economic reform policies since the late 1980s have emphasized autonomous enterprises and the utilization of market mechanisms. We currently expect that the Chinese government will continue these reforms, further reduce government intervention and rely more heavily on market mechanisms to allocate resources. Although we believe these reforms will have a positive effect on our overall long-term development, we cannot predict whether changes to China's political, economic and social conditions, laws, regulations and policies will have any adverse effect on our current or future business or results of operations.

If the Chinese government changes current regulations that allow us to make payments in foreign currencies, we may be unable to obtain the foreign currency which is necessary for our business.

The Renminbi currently is not a freely convertible currency. We receive most of our revenue in Renminbi. A portion of our Renminbi revenue must be converted into other currencies to meet our foreign currency obligations. We have substantial requirements for foreign currency, including:

- debt service costs on foreign currency-denominated debt;
- purchases of imported equipment;
- payment of any cash dividends declared in respect of the H shares; and
- import of crude oil and other materials.

Under existing foreign exchange regulations in China, we may undertake current account foreign exchange transactions, including the payment of dividends, without prior approval from the State Administration of Foreign Exchange by producing commercial documents evidencing the foreign exchange transactions, provided that they are processed through Chinese banks licensed to engage in foreign exchange transactions. The Chinese government has stated publicly that it intends to eventually make the Renminbi freely convertible in the future. However, uncertainty exists as to whether the Chinese government may restrict access to foreign currency for current account transactions if foreign currency becomes scarce in China.

Foreign exchange transactions under the capital account (international revenues and expenditures that increase or decrease debt or equity, including principal payments in respect of foreign currency-denominated obligations) continue to be subject to limitations and require the prior approval of the State Administration of Foreign Exchange. These limitations could affect our ability to obtain foreign exchange through debt financing, or to make capital expenditures in foreign currency.

If the Chinese government restricts our ability to make payments in foreign currency, we may be unable to obtain the foreign currency which is necessary for our business. In that case, our business may be materially adversely affected, and we may default on our obligations.

Changes in the PRC government's currency policy and fluctuations in the value of the Renminbi may adversely affect our business and operating results.

The value of the Renminbi against the US dollar and other currencies may fluctuate and is affected by, among other things, changes in China's political and economic conditions. Historically, the People's Bank of China has set the conversion of Renminbi into foreign currencies, including US dollars. On July 21, 2005, the PRC government significantly changed its policy of pegging the value of the Renminbi to the US dollar by permitting the Renminbi to fluctuate within a narrow band against a basket of certain foreign currencies. Since the adoption of this new policy, the value of Renminbi against the US dollar has fluctuated daily within a narrow band, but overall has appreciated against the US dollar. In addition, the PRC government continues to receive significant international pressure to further liberalize its currency policy and as a result may further change its currency policy.

A small portion of our cash and cash equivalents is denominated in foreign currencies, including the US dollar. Any increase in value of the Renminbi against other currencies, including the US dollar, may decrease the Renminbi value of our cash and cash equivalents that are denominated in foreign currencies. On the other hand, most of our revenues are denominated in Renminbi but a major part of our procurement of crude oil and certain equipment as well as certain debt repayments are denominated in foreign currencies. Any devaluation of the Renminbi in the future will increase our costs and jeopardize our profitability. Any devaluation of the Renminbi may also have an adverse impact on the value of dividends payable in foreign currencies by the Company for H shares and ADSs.

Changes in PRC tax laws may adversely affect our business and operating results.

We are currently subject to a PRC corporate income tax rate of 15%. If our previous tax privilege is revoked by the relevant government authorities as a result of new laws or regulations or for any other reason, our financial condition may be materially and adversely affected. In particular, on March 16, 2007, the National People's Congress promulgated the "Enterprise Income Tax Law of the PRC" (the "New Enterprise Income Tax Law"). According to the new law, beginning on January 1, 2008, the enterprise income tax rate for both domestic and foreign invested entities, other than certain qualified non-resident enterprises, high technology enterprises and small-scale enterprises, will be 25%. In addition, certain enterprises that are currently taxed at preferential rates will be subject to a five-year transition period during which their tax rate will be gradually increased to the unified tax rate of 25%. The State Council of the PRC is in the process of formulating detailed rules and regulations regarding the implementation of this new tax law. Due to a variety of uncertain factors regarding the application of this new law, we currently are unable to accurately assess the new law's impact on us. However, our business and operating results will be adversely affected to the extent that we become subject to the 25% tax rate under the new law. In addition, our historical operating results may not be indicative of our operating results for future periods as a result of the potential expiration or phasing out of our current 15% tax rate.

Our inability to gain shareholder approval for certain share reforms required of companies listed on the Shanghai Stock Exchange may adversely affect our market image and our ability to effectuate future transactions such as public offerings on the Shanghai Stock Exchange.

Pursuant to regulations issued by the China Securities Regulatory Commission (the "CSRC"), we were required to gain shareholder approval for and implement certain share reforms last year. Under the share reform plan proposed by holders of our non-circulating A Shares, all non-circulating A Shares would be converted into circulating A Shares and may be sold publicly on the Shanghai Stock Exchange subject to any applicable lock-up period under the condition that holders of our non-circulating A Shares

transfer a portion of their A Shares to holders of our circulating A Shares. However, holders of our circulating A Shares rejected such share reform plan. No specific new proposals have yet been presented to implement the required share reforms. We are uncertain as to when such share reforms will be completed. On January 8, 2007, the Shanghai Stock Exchange began to impose stricter regulations on its listed companies that are required but unable to complete the share reforms, including stricter trading information disclosure requirements and greater restrictions on their ability to effectuate future public offerings. Since March 26, 2007, the Shanghai Stock Exchange has required us to make weekly public announcements regarding the status of our share reforms. In addition, the CSRC is expected to more strictly scrutinize any securities-related applications by publicly listed PRC companies that are required to but have failed to complete such share reforms, their major shareholders and ultimate beneficial owners. Our inability to complete such share reforms may adversely affect our market image and our ability to effectuate future transactions such as public offerings on the Shanghai Stock Exchange.

Interpretation and enforcement of Chinese laws and regulations is uncertain.

The Chinese legal system is based on statutory law. Under this system, prior court decisions may be cited as persuasive authority, but do not have the binding effect of precedents. Since 1979, the Chinese government has been developing a comprehensive system of commercial laws and considerable progress has been made in the promulgation of laws and regulations dealing with economic matters, such as corporate organization and governance, foreign investment, commerce, taxation and trade. Because these laws, regulations and legal requirements are relatively new and not all accessible to the public and because prior court decisions have little precedential value, the interpretation and enforcement of these laws, regulations and legal requirements involve greater uncertainty than in other jurisdictions.

You may not enjoy shareholders' protections that you would be entitled to in other jurisdictions.

As most of our business is conducted in China, our operations are governed principally by the laws of China. Despite recent changes to the PRC Company Law, Chinese legal provisions for the protection of shareholders' rights and access to information are different and less developed than those applicable to companies formed in the United States, Hong Kong, the United Kingdom and other developed countries or regions. You may not enjoy shareholders' protections under Chinese law that you would be entitled to in other jurisdictions.

Our Articles of Association require you to submit your disputes with us and other persons to arbitration. You will have no legal right to a court proceeding.

Our Articles of Association require holders of our H shares or ADSs having a claim against, or a dispute with, us, our directors, supervisors, executive officers or a holder of our domestic shares relating to any rights or obligations conferred or imposed by our Articles of Association, the Chinese Company Law or any other Chinese laws or regulations relating to our affairs, to submit such claim or dispute to arbitration with the China International Economic and Trade Arbitration Commission or to the Hong Kong International Arbitration Center. Our Articles of Association further provide that any arbitration decisions with respect to such disputes or claims shall be final and binding on all parties.

We may be or become a passive foreign investment company, which could result in adverse U.S. federal income tax consequences to U.S. investors.

We may be classified as a passive foreign investment company ("PFIC") by the U.S. Internal Revenue Service for U.S. federal income tax purposes. Such characterization could result in adverse U.S. federal income tax consequences to you if you are a U.S.

investor. For example, U.S. investors who owned our ADSs during any taxable year in which we were a PFIC generally are subject to increased U.S. tax liabilities and reporting requirements for that taxable year and all succeeding years, regardless of whether we actually continue to be a PFIC, although a shareholder election to terminate such deemed PFIC status may be available in certain circumstances. The same adverse U.S. federal income tax consequences will apply to U.S. investors who acquire our ADSs during the current taxable year of 2007 or any subsequent taxable year if we are treated as a PFIC for that taxable year.

The determination of whether or not we are a PFIC is made on an annual basis and depends on the composition of our income and assets, including goodwill, from time to time. Specifically, we will be classified as a PFIC for U.S. tax purposes for a taxable year if either (a) 75% or more of our gross income for such taxable year is passive income, or (b) 50% or more of the average percentage of our assets during such taxable year either produce passive income or are held for the production of passive income. For such purposes, if we directly or indirectly own 25% or more of the shares of another corporation, we will be treated as if we (a) held directly a proportionate share of the other corporation's assets, and (b) received directly a proportionate share of the other corporation's income.

We do not believe that we are currently a PFIC. However, because the PFIC determination is highly fact intensive and made at the end of each taxable year, there can be no assurance that we will not be a PFIC for the current or any future taxable year or that the IRS will not challenge our determination concerning our PFIC status. For further discussion of the adverse U.S. federal income tax consequences of our possible classification as a PFIC, see "Taxation" below.

ITEM 4. INFORMATION ON THE COMPANY.

A. History and Development of the Company

General Information

We were established in the People's Republic of China as a joint stock limited company under the Chinese Company Law on June 29, 1993 as Shanghai Petrochemical Company Limited. On October 12, 2000, we changed our name to Sinopec Shanghai Petrochemical Company Limited. Our registered office is at No. 48 Jinyi Road, Jinshan District, Shanghai, China 200540. Our telephone number there is (86-21) 5794-1941.

Our Predecessor

Our predecessor, Shanghai Petrochemical Complex (the "Complex"), was founded in 1972 as one of the first large scale Chinese petrochemical enterprises using advanced imported technology and equipment. Prior to June 29, 1993, the Complex was wholly-owned by China Petrochemical Corporation, at the time a ministerial level enterprise (before its restructuring in 1998, "Sinopec"). The Complex's location was chosen because of accessibility by water and land transportation to Shanghai, a major industrial city of China, and the availability of reclaimable land. The Complex was initially under the administration of the Ministry of Textile Industry and in 1983 was placed under the administration of Sinopec.

The Complex and we, as its successor, have undergone four major stages of construction. The first stage of construction (1972-1976) included reclamation of land and the installation of 18 production units. The second stage of construction (1980-1986) increased the Complex's capacity for processing crude oil and doubled its capacity for synthetic fiber production. The third stage of construction (1987- 1992) primarily consisted of the installation of a 300,000 ton Rated Capacity ethylene unit, an additional crude oil

refining unit and other units for the production of petrochemical products. The third stage of construction completed our transition from a synthetic fiber producer to a highly integrated producer of a wide variety of petrochemical products. The fourth stage of construction (2000-2002) mainly included the 700,000 ton Ethylene Expansion Project and Coal-Fired Power Plant Expansion Project which is described under Item 4. Information on the Company – Property, Plant and Equipment – Capital Expansion Program.

Over the past twenty years, the Complex built up an infrastructure system to support its production needs. The Complex has its own facilities to supply water, electricity, steam and other utilities and to treat waste water, as well as ocean and inland waterway wharfs and railroad and road transportation facilities.

Our Initial Public Offering and Listing

We were established as a subsidiary of Sinopec on June 29, 1993. In preparation for our initial public offering of ordinary shares, all assets and liabilities of the Complex were transferred either to us or to Sinopec Shanghai Jinshan Industrial Company (“JI”), a separate subsidiary of Sinopec. The Complex’s non-core businesses and assets, such as housing, stores, schools, transportation and medical services were transferred to JI. The Complex’s core business and assets was transferred to us. The Complex then ceased to exist as a legal entity. In 1998, Sinopec was restructured into a limited liability company under the name of China Petrochemical Corporation (“Sinopec Group”). On February 25, 2000, Sinopec Group transferred its interest in us to its subsidiary, Sinopec Corp. In 1997, JI was restructured and its subsidiaries were either transferred to Sinopec or Shanghai Jinshan District. Sinopec Group now provides community services to us that were formerly provided by JI.

Our H Shares are listed on the HKSE. Our ADSs, each representing 100 H Shares, are listed on the New York Stock Exchange (“NYSE”). Our A Shares are listed on the Shanghai Securities Exchange. We were the first Chinese joint stock limited company to have securities concurrently traded in Hong Kong, the United States and China. On November 8, 1993, our A Shares were included in the Shanghai Securities Exchange Stock Index.

Description of Principal Capital Expenditures and Divestitures

In the fourth quarter of 2001, we established a Sino-foreign equity joint venture, Shanghai Secco Petrochemical Company Limited (“Secco”), together with BP Chemicals East China Investments Limited (“BP”) and Sinopec Corp. We own 20%, while BP and Sinopec Corp own 50% and 30% of the equity interest of Secco, respectively. Secco was established to build and operate a 900,000 ton Rated Capacity ethylene petrochemical manufacturing facility in order to manufacture and market ethylene, polyethylene, styrene, polystyrene, propylene, acrylonitrile, polypropylene, butadiene, aromatics and by-products; provide related after-sales services and technical advice with respect to such petrochemical products and by products; and engage in polymers application development. Secco completed construction in 2005. Secco’s registered capital is US\$901,440,964 of which we were obligated to contribute an amount in Renminbi equivalent to US\$180,287,952 prior to the end of 2005. As of December 31, 2005, we had contributed such amount in full. For a description of capital expansion projects related to our facilities, see Item 4. Information on the Company – Property, Plant and Equipment – Capital Expansion Program.

B. Business Overview

We are one of the largest petrochemical companies in China based on 2006 net sales and ethylene production. Our highly integrated petrochemical complex processes crude oil into a broad range of products in four major product areas:

- synthetic fibers,
- resins and plastics,
- intermediate petrochemicals, and
- petroleum products.

Based on 2006 sales volumes, we are a leading Chinese producer of synthetic fibers and resins and plastic products. We believe that we are also a leading competitor in sales of petroleum products and intermediate petrochemicals in our regional markets.

Our net sales by product category, as a percentage of total net sales in each of 2006, 2005 and 2004 are summarized as follows:

Net Sales of RMB 49,918 million (US\$6,392.61 million) in 2006

Synthetic fibers	9.44%
Resins and plastics	31.56%
Intermediate petrochemicals	13.57%
Petroleum products	38.84%
All others	6.59%
Total:	100.00%

Net Sales of RMB 45,190 million (US\$5,599.61 million) in 2005

Synthetic fibers	10.54%
Resins and plastics	30.89%
Intermediate petrochemicals	14.51%
Petroleum products	39.73%
All others	4.33%
Total:	100.00%

Net Sales of RMB38,664 million (US\$4,671.54 million) in 2004

Synthetic fibers	12.29%
Resins and plastics	31.26%
Intermediate petrochemicals	15.25%
Petroleum products	33.89%
All others	7.31%
Total:	100.00%

We derive a substantial portion of our revenues from customers in Eastern China (principally Shanghai and its six neighboring provinces), an area that has experienced economic growth above the national average in recent years. We believe that we are well-positioned to take advantage of opportunities which may arise through the growth of the Chinese economy generally and in this area in particular. Shown by geographic region and exports, our net sales by product category as a percentage of total net sales for each of 2006, 2005 and 2004 are as follows:

2006 Net Sales by Region (%)

	<u>Eastern China</u>	<u>Other parts of China</u>	<u>Exports</u>
Synthetic fibers	78.89	19.36	1.75
Resins and plastics	86.26	13.73	0.01
Intermediate petrochemicals	92.02	7.13	0.85
Petroleum products	99.65	0.35	0.00

2005 Net Sales by Region (%)

	<u>Eastern China</u>	<u>Other parts of China</u>	<u>Exports</u>
Synthetic fibers	75.86	22.47	1.67
Resins and plastics	92.53	7.46	0.01
Intermediate petrochemicals	91.95	7.80	0.25
Petroleum products	99.33	0.67	0.00

2004 Net Sales by Region (%)

	<u>Eastern China</u>	<u>Other parts of China</u>	<u>Exports</u>
Synthetic fibers	92.96	6.18	0.86
Resins and plastics	88.87	11.00	0.13
Intermediate petrochemicals	94.06	5.24	0.70
Petroleum products	99.97	0.00	0.03

Business Strategy

Our strategy is to develop our leading role in the Chinese petrochemical industry by increasing production capacities, particularly for higher-margin products, and improving operating efficiencies. In the long term, we aim to increase annual production of ethylene from the current 900,000 tons to more than one million tons. This would give us the feedstock necessary to significantly expand our production of higher-margin products. In order to pursue this goal, we are positioning ourselves for larger-scale projects and acquisitions by maintaining various financing options.

In the near-term, our goal is to:

- further streamline our production capacity by focusing on our aromatics-polyester products and by increasing our capacity to produce key intermediate products such as ethylene and propylene, and
- produce higher-margin products, including certain resin and plastic products, and intermediate petrochemicals, by adding or expanding production capacity.

In order to support our ethylene expansion and to provide additional capacity and flexibility, we also plan to expand and renovate our oil refining capabilities. This expansion and renovation will enable us to produce additional feedstock for our ethylene expansion. By adding processing units to refine vacuum gas oil (“VGO”) and residual oil, we should be able to produce more higher-margin petroleum products such as gasoline and diesel products and certain intermediate petrochemical products which can be sold or used as feedstock for our own downstream products.

We are also implementing plans on a continuous basis for improving operating efficiencies. These are designed to: (i) gain incremental improvements in capacity utilization from our existing facilities; (ii) reduce maintenance downtime by adopting more sophisticated maintenance and repair techniques; (iii) implement additional financial and operational reporting systems for better cost controls; and (iv) enable us to monitor market conditions and adjust our pricing and product mix accordingly.

Principal Products

We produce over 60 different types of products representing a broad range of synthetic fibers, resins and plastics, intermediate petrochemicals and petroleum products. We use many of the important petroleum products and intermediate petrochemicals we produce in producing our own downstream products. The following table shows our 2006 net sales by major product as a percentage of total net sales together with the typical uses of these products.

Product	% of net sales	Typical Use
SYNTHETIC FIBERS		
Polyester staple fiber	1.59	Textiles and apparel
Acrylic staple fiber	4.74	Woven into fabrics or blended with other material fabrics to make fabric or acrylic top
Acrylic top	2.13	High bulk hand knitting yarn, blankets and fabrics
Polypropylene	0.01	Industrial unwoven fabric, and textiles and apparel
Others	0.97	
Sub-total	9.44	
RESINS AND PLASTICS		
Polyester chips	8.45	Polyester fibers, films and containers
PE pellets	12.47	Films, ground sheeting, wire and cable compound and other injection molding products such as housewares and toys
PP pellets	9.56	Extruded films or sheets, injection molded products such as housewares, toys and household electric appliance and automobile parts
PVA	1.02	PVA fibers, building coating materials and textile starch
Others	0.06	
Sub-total	31.56	
INTERMEDIATE PETROCHEMICALS		
Ethylene	1.77	Feedstock for Polyethylene, EG, PVC and other intermediate petrochemicals which can be further processed into resins and plastics and synthetic fiber.
Ethylene oxide	1.01	Intermediate for chemical and pharmaceutical industry, dyes, detergents and auxiliary agents
Benzene	3.42	Intermediate petrochemical products, styrene, plastics, explosives, dyes, detergents, epoxies and nylon
Butadiene	2.59	Synthetic rubber and plastics
Ethylene glycol	0.14	Fine chemicals
Others	4.64	
Sub-total	13.57	
PETROLEUM PRODUCTS		
Gasoline	5.93	Transportation fuels
Diesel	20.36	Agricultural fuels
Jet Fuel	4.30	Transportation fuels
Others	8.25	
Sub-total	38.84	
All others	6.59	

Total	<u>100.00</u>
--------------	---------------

Production Processes

The key sectors in our vertically integrated production facilities are the ethylene units which produce ethylene and propylene, and our aromatics plants which principally produce paraxylene (“PX”) and benzene. Ethylene is the major raw material in the

production of polyethylene (“PE”) and polyvinyl acetate (“PVA”). Ethylene is also used to make monoethylene glycol (“MEG”) which, together with pure terephthalic acid (“PTA”), is used to manufacture polyester. Propylene is the major raw material in the production of acrylonitrile and polypropylene (“PP”). These products are produced through the processing of a series of petrochemical units from crude oil. Our production processes are shown in the flow chart below.

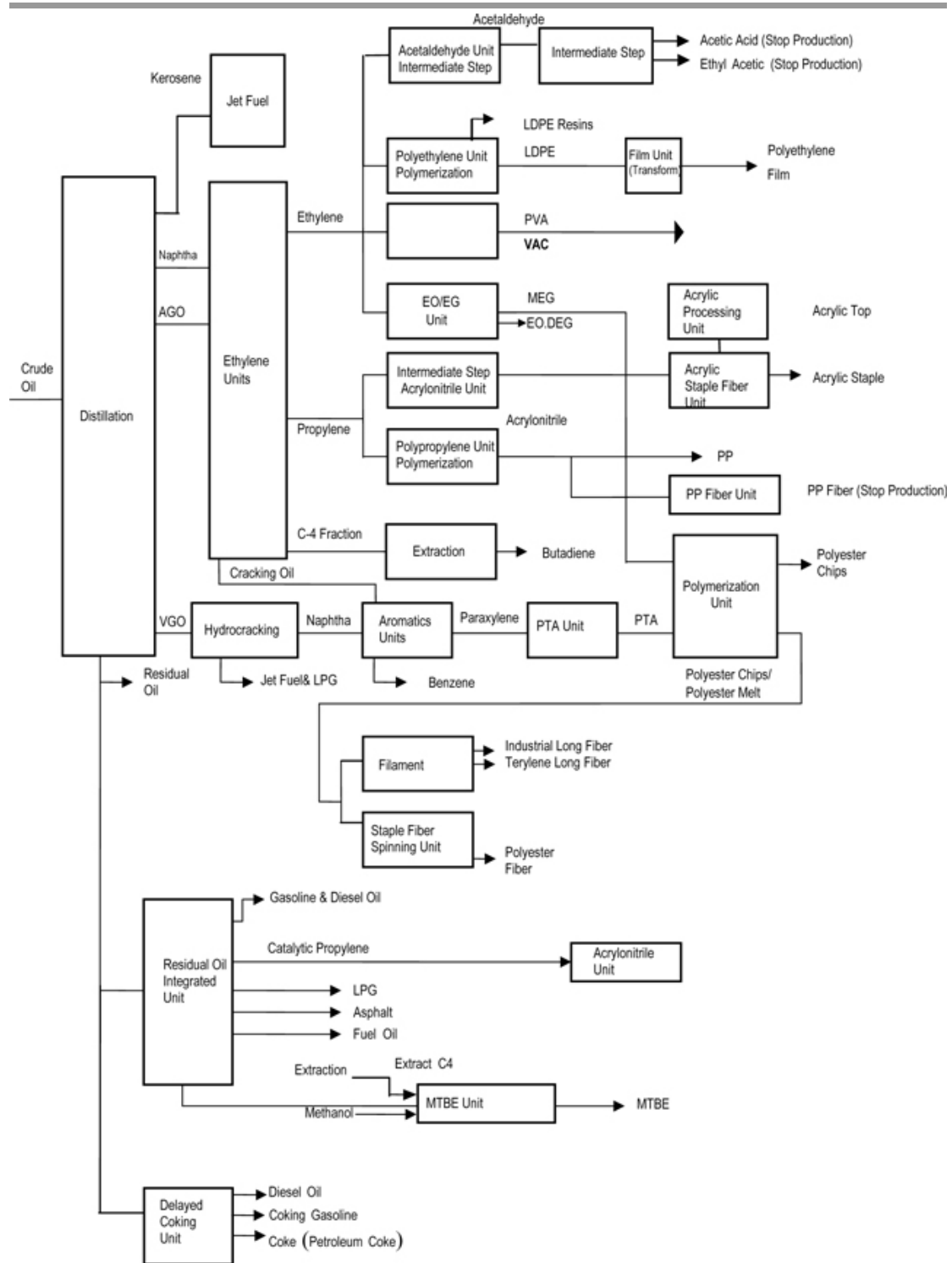

Our refinery units refine crude oil into five basic components: (1) naphtha, (2) kerosene, (3) atmospheric gas oil (“AGO”), (4) VGO, and (5) residual oil. Naphtha and part of the AGO is fed to the ethylene units primarily to produce ethylene and propylene. The other part of the AGO is processed into diesel oil, and kerosene is fed to the jet fuel sweetening unit to produce jet fuel. Part of the VGO is further processed in a hydrocracking unit producing mainly light and heavy naphtha, liquefied petroleum gas (“LPG”), diesel oil, various aromatic hydrocarbon products and jet fuel. The other part of the VGO and residual oil can be further processed into gasoline, diesel oil, LPG, propylene and other products.

Intermediate Petrochemicals

Ethylene – Ethylene is either directly processed into PE resins or processed into other intermediate petrochemicals. The most important of these is MEG. MEG is a key ingredient in polyester. It is produced by oxidizing ethylene in the ethylene oxide (“EO”)/ethylene glycol (“EG”) unit. Ethylene is also used to produce vinyl acetate which is processed into PVA.

Propylene – Propylene is either processed directly into PP resins or is further processed into other intermediate petrochemicals such as acrylonitrile, acetonitrile, hydroxyl acetonitrile and sodium cyanide. Acrylonitrile is used in producing acrylics.

Vacuum gas oil – VGO is passed through the hydrocracker, and the resulting heavy naphtha is fed into the aromatics plants to produce PX and benzene. PX is processed into PTA, one of the principal raw materials in producing polyester.

Resins and Plastics and Synthetic Fibers

We process our intermediate petrochemical products into five kinds of synthetic fiber raw materials: (1) polyester, (2) acrylonitrile, (3) PP, (4) PE and (5) PVA. Each of these five products has its own production line or lines. We further process polyester, acrylonitrile and polypropylene into various types of synthetic fibers.

Polyester – MEG and PTA are fed into a polymerization unit which produces polyester chips and polyester melt. Both chips and melt are used as raw materials in the production of polyester staple and filaments. Some chips are also sold to third parties.

Polyester staple fiber is a multi-strand fiber cut into short lengths which can be spun into fabric on its own or blended with cotton, wool or flax to produce textiles. Polyester filaments are a class of more highly processed polyester materials which have been drawn and oriented to produce a long thread-like fiber.

Acrylonitrile – We produce polyacrylonitrile by feeding acrylonitrile into a polymerization unit. By passing the polyacrylonitrile through the fiber unit, acrylic fiber and acrylic staple fiber are produced, including cotton and wool type staple fibers. Wool acrylic staple fiber can be processed into acrylic wool strips.

Polypropylene – We produce PP resins by feeding propylene into a polymerization unit. Our fiber grade PP resin is the main ingredient for PP fiber production.

Polyethylene – We have three sets of units producing PE, two of which produce LDPE using the kettle type process, and the other unit produces all density PE products using the Borstar bimodal process.

Polyvinyl acetate – PVA granules are produced from vinyl acetate (“VAC”), derived from ethylene.

Raw Materials

Crude Oil

Crude oil is our primary raw material and the most significant raw material we purchase from outside sources. In 2006, crude oil accounted for approximately 67.72% of our total cost of sales. Accordingly, the supply and price of crude oil are key factors in determining our profitability.

Allocation and Transportation – The Chinese government exercises centralized management and control of the distribution of all crude oil, whether from domestic or foreign sources, and major petroleum products within China. Under this system, all our crude oil must be allocated by Sinopec Corp. During 2006, we did not experience any significant problems in obtaining sufficient crude oil to meet our production needs.

Sinopec Group is responsible for preparing an annual plan on demand and supply for crude oil and petroleum products that forms the basis of the Chinese government’s annual “balancing plan” which effectively dictates how much crude oil we will receive each year. Further, because the plan applies not only to domestic onshore oil, but also to domestic offshore oil and imported crude oil, we must consult with Sinopec Group in order to switch to domestic offshore oil or imported crude oil to reduce our cost. Likewise, under the “balancing plan”, some of our petroleum products are designated for sale to the subsidiaries of Sinopec Group or other designated customers and we must consult Sinopec Group to sell elsewhere. Therefore, we cannot freely sell our petroleum products to take advantage of any opportunities for higher-priced sales.

We have received confirmation from Sinopec Corp that we will receive an allocation of 0.23 million tons of domestic onshore and offshore crude oil and 8.67 million tons of foreign crude oil in 2007. Sinopec Corp has further confirmed that, subject to China’s national crude oil policy, it will continue to allocate sufficient quantities and appropriate kinds of crude oil to us, including domestic onshore, domestic offshore and foreign crude oil, for our anticipated annual needs. We anticipate fully utilizing our 2007 allocation of crude oil. We believe that the mix of crude oil feedstocks currently available is satisfactory for our 2007 production capacity and targets. Additionally, as part of China’s commitment at its accession into WTO, certain non-state-owned enterprises have been granted an increasing quota to import crude oil. Although we do not expect to obtain crude oil through this channel in the foreseeable future due to the current crude oil allocation system, this may provide us with an alternative source of crude oil supply.

Crude Oil Mix – Our refining equipment is designed to process certain grades of crude oil. Therefore, the origin and quality of the crude oil available can be important to our business. We believe, as we are significantly increasing usage of foreign crude oil, we will continue to be able to obtain such foreign crude oil that is compatible with our refining equipment. The overall mix of foreign versus domestic crude oil we process in 2007 will depend on a variety of factors, including the amount of future allocations of domestic onshore crude oil and the availability, price, quality, processing profitability and compatibility with our refining capabilities of foreign crude oil. Provided there are no significant modifications to the existing crude oil allocation policy, we believe that sufficient supplies of crude oil will be available on the domestic or international markets for our 2007 production capacity and goals.

In 2006, our crude oil was sourced as follows:

Domestic offshore	3.96%
Foreign crude oil	96.04%
Total:	100.00%

As a result of a consistent decrease in the supply of domestic crude oil, we expect that we will continue to rely principally on foreign sources for our crude oil supply. However, we believe that we will be able to maintain our processing efficiency through technological adjustments of our equipment and quality control and that increased use of imported oil will not materially adversely impact our business and results of operations.

Foreign and domestic offshore crude oil is supplied by tanker to our oil terminal wharf. See Item 4.D. Property, Plants and Equipment -Wharfs.

In the past, we have not experienced disruption in our crude oil supply. We have on-site crude oil storage tanks at Chenshan wharf capable of storing approximately 300,000 cubic meters of crude oil, primarily to provide crude oil to our No. 2 atmosphere vacuum distillation facility. This crude oil storage can provide us with approximately a 20 day supply of crude oil. The crude oil for our No. 3 atmosphere vacuum distillation facility is mainly supplied from the Ningbo-Shanghai-Nanjing oil pipeline. Due to our ability to obtain crude oil from multiple sources, we are able to meet our normal requirements for crude oil.

Pricing – The price of domestic onshore crude oil is controlled by China National Petroleum Corporation (“CNPC”) and Sinopec Group based on government pricing policies, while the price of foreign and domestic offshore crude oil is generally allocated to us at prevailing international market prices. The average cost of foreign and domestic offshore crude oil in 2006 was RMB 3,787 (US\$484.97) per ton and RMB 3,636 (US\$465.63) per ton, respectively. In 2006, we processed 8.572 million tons of foreign crude oil and 348,300 tons of domestic offshore crude oil.

Until March 2001 the Chinese government implemented a unified pricing system for crude oil. Each month, the National Development and Reform Commission (“NDRC”) would establish an indicative price for each grade of domestic onshore crude oil based on comparable international market prices, inclusive of any duties that would have been imposed had the oil been imported. The actual price for domestic onshore oil would be such indicative price plus a surcharge. This surcharge was determined by CNPC and Sinopec Group to reflect any transportation and other miscellaneous costs that would have been incurred in having the oil delivered to various refineries. Beginning March 2001, the NDRC ceased publishing an indicative price. Instead, the indicative price for domestic onshore oil is calculated and determined directly by CNPC and Sinopec Group based on the principles and methods formerly applied by the NDRC.

Sinopec Corp has undertaken that it will allocate crude oil to us in quantities and at prices no less favorable than the quantities received and prices paid by other enterprises that it controls. On this basis, we believe that changes in crude oil prices should not have a material effect on our competitiveness with other domestic producers. Nevertheless, any increase in the price of crude oil could have an adverse impact on our profitability to the extent that we are unable to pass cost increases on to our customers.

Coal

Unlike crude oil, coal is not subject to government allocation. We purchase coal directly from the Datong mines in Shanxi Province. Coal is transported by rail from the mines to Qinhuangdao port and shipped by barge to Jinshanwei where it is delivered to the plant via a wharf and conveyer system. Our cost of coal is materially dependent on transportation charges. Although coal may be purchased from alternative sources, railroad transportation must be obtained by allocation from the Chinese government on a monthly basis.

We expect that our total requirement for coal to generate electricity in 2007 will be approximately 1.68 million tons. In 2006, we consumed approximately 1.60 million tons of coal, at the same level as in 2005.

Other Raw Materials

We produce most of the raw materials used as feedstock for our operations. If any of these raw materials, other than ethylene, becomes unavailable from internal production, we believe that there are sufficient alternative sources at reasonable prices and the unavailability of raw materials from internal sources will not have a significant effect on our operations and profitability.

We purchase some ancillary raw materials from outside sources. These raw materials include methanol, ammonia, sodium hydroxide, sulfur, acetone, acrylonitrile, PTA, propylene and a variety of catalytic agents. In 2006, the total cost of these materials accounted for approximately 16.07% of our total cost of sales. We do not expect any difficulties in obtaining a supply of any of these ancillary raw materials in amounts sufficient to meet our needs in the foreseeable future.

Sales and Marketing

Distribution

The distribution of our petroleum products is subject to government regulations. We are required to sell certain petroleum products to the subsidiaries of Sinopec Group or customers designated by Sinopec Group. Since the second half of 2005, Sinopec Group has executed reforms to its system of selling petrochemical products and implemented what it refers to as a “Five Consolidations” strategy featuring “consolidated marketing strategy, consolidated promotion, consolidated logistics optimization, consolidated sales and consolidated branding”. As a result, the sales of our major petrochemical products are now conducted in a consolidated manner by sales agents designated by Sinopec Group. However, we have the autonomy to decide on the distribution method of our other products in accordance with market conditions. The products we sold in 2006 that were subject to unified distribution by the government, sales by agents and sales based on our own discretion accounted for 51.68%, 34.62% and 13.70%, respectively, of the total products we sold.

We generally sell our products to larger trading companies and industrial users with whom we have long-standing relationships, including Sinopec Group or customers designated by Sinopec Group. We believe that the transition to sales of major petrochemical products by agents designated by Sinopec will increase our distribution efficiency by allowing us to benefit from Sinopec Group’s extensive and highly specialized sales network. It will also allow us to focus more of our resources on reducing production costs and enhancing our technical support.

We use long-term contracts to sell most of our products. We did not experience significant write-offs or defaults on our accounts receivable or other trade accounts in 2006. We generally do not experience seasonal fluctuations in product sales.

Product breakdown

Synthetic Fibers – In 2006, 7.78% of our synthetic fiber products were purchased by provincial and municipal government trading companies that act as intermediaries between us and end-users. No single customer accounted for more than 11.86% of our sales of synthetic fibers in 2006.

Resins and Plastics – In 2006, approximately 5.52% of our resins and plastics sales were to provincial and municipal government trading companies and approximately 49.81% were sold to industrial users. No single customer accounted for more than 3.74% of our sales of resins and plastics in 2006.

Intermediate Petrochemicals – We sell a variety of intermediate petrochemical products, none of which were sold in substantial quantities.

Shanghai Chlor-Alkali Chemical Co. Ltd. (“Chlor-Alkali”) is the principal outside consumer of our ethylene. In 2006, we sold 87,100 tons of ethylene, representing 9.07% of our total 2006 production of such product, to Chlor-Alkali at market prices. We expect to sell 82,000 tons of ethylene to Chlor-Alkali in 2007.

Petroleum Products – In 2006, our primary gasoline and diesel customer was Sinopec Sales Company Eastern China Branch Company. We sold residual oil directly to industrial end-users for use as industrial fuel and as feedstock to produce high-margin petroleum products.

Product Pricing

Most of our products other than petroleum products are permitted to be sold at market prices. However, three types of petroleum products, gasoline, diesel and jet fuel, and certain other major products we sell are subject to varying degrees of government pricing control and are, accordingly, sold at prices set by the Chinese government, which are often below our costs. In 2004, 2005 and 2006, approximately 57%, 58% and 53.96% of our net sales were from products subject to price controls. Price controls may apply to these products in various ways. Such pricing controls are sometimes applied exclusively to our products, exclusively to our competitors’ products or sometimes applied to neither our products nor our competitors’ products. We believe that the Chinese government will continue relaxing state control over the pricing of petroleum products over time.

For products that are not subject to price controls, we set our prices with reference to prices in the major Chinese chemical commodities markets in Shanghai and other parts of China. We also monitor pricing developments in major international commodities markets, particularly in Southeast Asia. In most cases, we revise product prices each month, or more frequently during periods of price volatility. Due to our economies of scale, brand recognition and high quality of products, we believe that we can continue to price our products competitively.

Competition

We compete principally in the Chinese domestic market where 99.88% of our products were sold in 2006. In addition, the limited transportation infrastructure in China and the difficulties involved in transporting petrochemical products force companies to compete primarily on a regional basis. In 2006, 92.34% of our net sales were made to customers in Eastern China.

Our Competitive Advantages

We believe our primary competitive advantages are quality of product, pricing, brand recognition, geographic location and vertical integration. We have received many prizes and awards from both central and local government authorities for high product quality. Furthermore, our location on the outskirts of the densely populated and highly industrialized Shanghai area places us in close proximity to many of our customers. This location also gives us convenient access to ocean transport and inland waterways, which results in a competitive advantage in terms of transportation cost and reliability and punctuality of product delivery. We believe this geographic advantage will be enhanced as China's accession into the WTO generates increasing demands for our products in Eastern China.

We believe that our vertical integration represents a significant competitive advantage over non-integrated competitors in China, both in terms of reliability in delivery and price. For most downstream products, our vertical integration results in significant savings on transportation and storage costs which would be incurred by less vertically integrated facilities.

The Domestic Competitive Environment

Prior to 1993, because distribution and pricing of our products were determined in accordance with the State Plan, we did not operate in a competitive environment. With the liberalization of control over pricing and product allocation by the Chinese government, competition in the domestic market has been gradually increasing.

Foreign Competition and the World Trade Organization

China joined the WTO on December 11, 2001. As part of its membership commitments, China agreed to eliminate certain tariff and non-tariff barriers to foreign competition in the domestic petrochemical industry that benefited us in the past. In particular, China has reduced tariffs on imported petrochemicals products that compete with ours from between 5% to 17% to between 2% to 14% with further reductions planned until they reach a range of between 0% and 6.5%. In accordance with its WTO commitments, China has made or plans to make the following changes:

- foreign investors are now permitted to wholly-own domestic petrochemical companies;
- restrictions on the import of crude oil by non-state owned companies are gradually relaxed;
- foreign-owned companies are granted the right to import petrochemical products; and
- foreign-owned companies are permitted to distribute and market petroleum products in both retail and wholesale markets in China.

As a result of these measures, we are facing increased competition from foreign companies and importation. Changes in crude oil importation and distribution could potentially affect our current supply arrangements with Sinopec Corp.

Prior to its entry into the WTO, the Chinese government took early steps to reduce protection from import barriers. Tariffs have been gradually reduced beginning in 1997. Foreign imports are likely to reduce prices for domestic petrochemical products and may

reduce our net sales. Nevertheless, we believe that our products have been, and will continue generally to be, competitive with imports. These early steps and recent tariff reductions have exposed us to international competition and should help us meet increased competition as China's WTO entry begins to affect our markets.

In addition to tariff reductions, China is liberalizing the import of crude oil and the distribution of processed oil and other petrochemical products. Import and export of crude oil has historically been limited to designated state-owned companies. China agreed to allocate 7.2 million tons of crude oil to non-state owned traders in 2002 and to increase this amount by 15% each year for 10 years, at which time the growth rate will be reviewed by interested WTO member countries. Similarly, several categories of processed oil are also subject to state owned trading. China will allocate 4.0 million tons of processed oils to non-state owned traders and increase this amount by 15% annually for 10 years.

In concurrent commitments, China has agreed that minority foreign-owned enterprises would receive trading rights by December 11, 2002, majority foreign-owned enterprises would receive trading rights by December 11, 2003 and wholly foreign-owned enterprises would receive trading rights by December 11, 2004. These changes could, in the long-term, open up alternative sources of crude oil that are not available to us today. We also expect that they will create additional foreign investment in China's petrochemical industry and additional competition for us.

Overall, we think that China's WTO entry will create substantial amounts of new investment and business in China, with a corresponding increase in sales opportunities for us. Although we are confident that we may be able to capture additional sales, the net effect of China's accession to the WTO on our business and results of operations remains to be seen.

Our Competitive Position

In the following discussion, internal consumption of resins and intermediate petrochemicals produced by integrated manufacturers in the production of downstream products are treated as sales.

Synthetic Fibers

In 2006, we had an approximate 1.93% share and imports had an approximate 5.03% share of total domestic polyester, acrylic and polypropylene consumption. We attribute the high level of imports to a variety of factors, including a shortage in the domestic supply and the importation of synthetic fibers into special economic zones in China, where tariffs are not imposed on imports processed for re-export.

The following table summarizes the competitive position of our principal synthetic fibers according to domestic sales in 2006.

<u>Product</u>	<u>Our share of domestic consumption (%)</u>	<u>Our competitive ranking</u>	<u>Location of principal domestic competitor</u>	<u>Principal domestic competitor's share of consumption (%)</u>	<u>Imports' share of consumption (%)</u>
Polyester staple fiber	1.40	2	Jiangsu	10.75	4.42
Acrylic	19.27	1	Jilin	12.09	28.72

Sources: Statistics provided to us by the Sinopec Group and the China National Council of Textiles.

Resins and Plastics

In 2006, we had an approximate 5.64% share and imports had an approximate 29.50% share of total domestic resins and plastics consumption. The following table summarizes the competitive position of our principal resins and plastics products according to domestic sales in 2006.

<u>Product</u>	<u>Our share of domestic consumption</u> (%)	<u>Our competitive ranking</u>	<u>Location of principal domestic competitor</u>	<u>Principal Domestic competitors' Share of consumption</u> (%)	<u>Imports' share of consumption</u> (%)
Polyester chips	6.02	3	Jiangsu	11.72	2.44
PVA granules	13.57	3	Shanxi	18.00	11.95
PE	5.52	5	Beijing	5.99	45.65
PP	5.16	1	Beijing	5.16	34.65

Sources: Statistics provided to us by Sinopec Group.

Intermediate Petrochemicals

In 2006, we were one of the largest sellers of intermediate petrochemicals in China and held an approximate 5.93% share of the total domestic consumption. Imports had an approximate 35.54% share of domestic consumption. Ethylene, benzene and butadiene are our major intermediate petrochemical products. In 2006, we were the largest ethylene producer in China.

Petroleum Products

In 2006, we had an approximate 2.14% share of the total domestic petroleum products market while imports had an approximate 6.17% share. Although we have one of the largest refining capabilities in China, we use most of our refining capacity to produce feedstock for our own downstream processing of petrochemical products.

The domestic markets for each of our major petroleum products are geographically concentrated because these markets tend to be highly localized with individual producers controlling a large share of the markets in their locality. In 2006, we sold approximately 99.65% of our petroleum products in Eastern China.

Investments

We established Secco, a Sino-foreign equity joint venture, in late 2001 together with BP and Sinopec Corp., primarily to build and operate a 900,000 ton Rated Capacity ethylene petrochemical manufacturing facility. Secco completed construction and commenced its manufacturing operations in 2005. We own 20% of the equity interest of Secco.

Under the PRC accounting rules and regulations, for the year of 2006, the sales revenue from principle activities of Secco was RMB 21.8 billion, 72% higher than the sales revenue of RMB 12.7 billion in 2005. Secco had a net loss of RMB743.7 million in 2005, but had a net profit of RMB 2,726.0 million in 2006, its first full year of production, as Secco's production volume grew substantially in 2006 compared to 2005, and also experienced varied degrees of price increases for its products. At the same time, Secco took a number of measures to control its costs and mitigate the effect of the price hikes of its raw materials, such as adjusting the mix of its production and further reducing unit consumption. In addition, under PRC accounting rules and regulations, all expenses incurred

during the start-up period are aggregated in long-term deferred expenses and then fully charged to the income statement in the month of commencement of operations. Because the pre-operating expenses of Secco had been fully charged to income statement as of the end of 2005 in accordance with PRC accounting rules and regulations, the general and administrative expenses of Secco were significantly lower in 2006 than in 2005.

Environmental Protection

We are subject to national and local environmental protection regulations, which currently impose a graduated schedule of fees for the discharge of waste substances, require the payment of fines for pollution and provide for the forced closure of any facility that fails to comply with orders requiring it to cease or cure certain environmentally damaging practices. We have established environmental protection systems to treat certain of our waste materials and to safeguard against accidents. Because of the nature of our business, however, we store and discharge into the environment a significant amount of waste substances. During 2006, we were assessed a total of RMB35.52 million (US\$4.55 million) in fees for discharges of waste substances. As of June 15, 2007, we had not been assessed any fines for environmental violations and there were no actions pending or, to our knowledge, threatened which would result in the assessment of such a fine.

We believe our environmental protection facilities and systems are adequate for the existing national and local environmental protection regulations. However, there can be no assurance that Chinese national or local authorities will not impose additional regulations that would require additional expenditures in respect of environmental matters in the future.

Insurance

We currently maintain insurance coverage with Sinopec Group which, as of December 31, 2006, was approximately RMB23.3 billion (US\$2.98 billion) on our property and facilities and approximately RMB1.3 billion (US\$0.17 billion) on our inventory. Transportation vehicles and products in transit are not insured by Sinopec Group. We maintain insurance policies for these assets with The People's Insurance Company of China. The Sinopec Group insurance coverage is compulsory and applies to all enterprises controlled by Sinopec Group, pursuant to guidelines of Sinopec Group which may not be legally enforceable against Sinopec Group. Thus, there is doubt under Chinese law as to whether we could enforce insurance claims against Sinopec Group.

We do not carry any third party liability insurance to cover claims in respect of personal injury, property or environmental damage arising from accidents on our property or relating to our operations other than on our transportation vehicles. We have not had a third party liability claim filed against us during the last five years. Since business interruption insurance is not customary in China, we do not carry such insurance.

Government Regulations

Following the development of several major oil fields and a growth in demand for petroleum and petrochemical products in China in the early 1970's, the Chinese government organized petroleum refining and petrochemical production and processing facilities into large complexes that would permit integrated production of petroleum products, intermediate petrochemicals, resins and plastics, and synthetic fibers.

Although the Chinese government is liberalizing its control over the petroleum and petrochemical industries in China,

significant government regulations that limit the business strategies available to us remain. Central government agencies and their local or provincial level counterparts do not own or directly control our production facilities. However, they exercise significant control over the petrochemical industry in areas such as pricing, production quotas, quality standards, allocation of raw materials and finished products, allocation of foreign exchange and Renminbi loans for capital construction projects. The Chinese government's intentions with respect to the development objectives and policies for the petrochemical industry are stated as part of the Five Year Plans for National Economic and Social Development formulated every five years. These plans at both the national and Shanghai municipality level have identified the petrochemical industry as a "pillar industry" which may qualify companies in the petrochemical industry for preferential treatment by governmental agencies.

Historically, we were supervised by Sinopec, a ministry-level enterprise under the direct supervision of the State Council, China's highest administrative body. As a result of a governmental restructuring in 1998, we became subject to the administration of the State Bureau of Petroleum and Chemical Industry. After its functions were terminated in March 2001, we became subject to the administration of the State Economic and Trade Commission. The State Economic and Trade Commission was dissolved in March 2003 and its function in directing the reform and management of state-owned enterprises were assumed by the State Assets Regulatory and Management Commission, its function in industry planning and policy making were assumed by NDRC, and its functions in administering domestic trade, coordinating and implementing import and export plans of critical industrial products and raw materials were assumed by the Ministry of Commerce. Since then, we have been subject to the industrial oversight of these three new governmental agencies at the national level.

As part of this restructuring, Sinopec was also restructured in July 1998. The succeeding entity, Sinopec Group, was authorized to conduct a petrochemical business and to control the exploration of crude oil and natural gas and crude oil refining, mainly in the southern and eastern regions of China. China Petroleum and Natural Gas Corporation, another major state-owned petrochemical company, was also restructured, renamed China National Petroleum Corporation and authorized to conduct the same type of business, mainly in the northern and western regions of China. On December 31, 1999, Sinopec Group completed a reorganization pursuant to which certain of its core oil and gas and chemical operations and businesses and related assets and liabilities were transferred to its subsidiary, Sinopec Corp, currently our controlling shareholder.

C. Organizational Structure.

Our Subsidiaries

Our significant subsidiaries are listed below. All of the subsidiaries named below are incorporated in China.

<u>Subsidiary Name</u>	<u>Our ownership interest and voting power (%)</u>
Shanghai Petrochemical Investment Development Company Limited	100.00
China Jinshan Associated Trading Corporation	67.33
Shanghai Golden Way Petrochemical Company Limited	75.00
Shanghai Jinchang Engineering Plastics Company Limited	50.38
Shanghai Golden Phillips Petrochemical Company Limited	60.00
Zhejiang Jin Yong Acrylic Fiber Company Limited	75.00
Shanghai Petrochemical Enterprise Development Company Limited	100.00
Shanghai Golden Conti Petrochemical Company Limited	100.00

Sinopec Corp

We are a member of a group (defined as a parent and all its subsidiaries) for purposes of the disclosure rules of the Securities and Exchange Commission. The parent company of this group is Sinopec Corp, our controlling shareholder. Sinopec Corp is operated by separate management and from time to time uses its interest as a shareholder to direct our policies and management. We have extracted the following information regarding Sinopec Corp from its public filings:

Overview

Sinopec Corp is an integrated petroleum and petrochemical company with upstream, midstream and downstream operations. Based on trading volume in 2006, Sinopec Corp is one of the largest publicly listed companies in China and one of the largest petroleum and petrochemical companies in both China and Asia. Sinopec Corp is one of the largest refiners, distributors and marketers of gasoline, diesel, jet fuel and most other major refined products in China and Asia with principal markets in the eastern and southern regions of China. Sinopec Corp is also a producer and distributor of petrochemicals in China and additionally explores, develops and produces crude oil and natural gas principally to supply its refining and chemical operations.

Subsidiaries

Details of Sinopec Corp's principal subsidiaries are given in the table below. Except for Sinopec Kantons Holdings Limited, which is incorporated in Bermuda, all of the above principal subsidiaries are incorporated in China.

Name of company	Particulars of issued capital (millions)	Type of legal entity	Percentage of equity		Principal activities
			held by Sinopec Group (%)	held by Sinopec Group's subsidiary (%)	
China Petrochemical International Company Limited	RMB 1,663	Limited company	100.00	—	Trading of crude oil and petrochemical products
Sinopec Sales Company Limited	RMB 1,700	Limited company	100.00	—	Marketing and distribution of refined petroleum products
Sinopec Zhenhai Refining and Chemical Company Limited ("Sinopec Zhenhai") (i)	RMB 2,524	Limited company	100.00	—	Manufacturing of intermediate petrochemical products and petroleum products
Sinopec Qilu Petrochemical Company Limited ("Sinopec Qilu") (ii)	RMB 1,950	Limited company	99.76	—	Manufacturing of intermediate petrochemical products and petroleum products
Sinopec Yangzi Petrochemical Company Limited ("Sinopec Yangzi") (ii)	RMB 2,330	Limited company	99.81	—	Manufacturing of intermediate petrochemical products and petroleum products
Sinopec Zhongyuan Petroleum Company Limited ("Sinopec	RMB 875	Limited company	99.35	—	Exploration and production of crude oil and natural gas

Zhongyuan”) (ii)

Sinopec Shengli Oil Field Dynamic Company Limited (“Dynamic”) (ii)	RMB 364	Limited company	97.71	—	Exploration and production of crude oil and distribution of petrochemical products
Sinopec Fujian Petrochemical Company Limited (iii)	RMB 2,253	Limited company	50.00	—	Manufacturing of plastics, intermediate petrochemical products and petroleum products

Name of company	Particulars of issued capital (millions)	Type of legal entity	Percentage of equity		Principal activities
			held by Sinopec Group (%)	held by Sinopec Group's subsidiary (%)	
Sinopec Shanghai Petrochemical Company Limited	RMB 7,200	Limited company	55.56	—	Manufacturing of synthetic fibers, resin and plastics, intermediate petrochemical products and petroleum products
Sinopec Shijiazhuang Refining- Chemical Company Limited	RMB 1,154	Limited company	79.73	—	Manufacturing of intermediate petrochemical products and petroleum products
Sinopec Kantons Holdings Limited	HK\$ 104	Limited company	—	72.40	Trading of crude oil and petroleum products
Sinopec Wuhan Petroleum Group Company Limited (iii)	RMB 147	Limited company	46.25	—	Marketing and distribution of refined petroleum products
Sinopec Yizheng Chemical Fiber Company Limited (iii)	RMB 4,000	Limited company	42.00	—	Production and sale of polyester chips and polyester fibers
Sinopec Zhongyuan Petrochemical Company Limited	RMB 2,400	Limited company	93.51	—	Manufacturing of chemical products
Sinopec Shell (Jiangsu) Petroleum Marketing Company Limited	RMB 830	Limited company	60.00	—	Marketing and distribution of refined petroleum products
BP Sinopec (Zhejiang) Petroleum Company Limited	RMB 800	Limited company	60.00	—	Marketing and distribution of refined petroleum products
Sinopec Qingdao Refining and Chemical Company Limited	RMB 800	Limited company	85.00	—	Manufacturing of intermediate petrochemical products and petroleum products
China International United Petroleum and Chemical Company Limited	RMB 223	Limited company	100.00		Trading of crude oil and petrochemical products
Sinopec Hainan Refining and Chemical Company Limited (“Sinopec Hainan”)	RMB 3,986	Limited company	75.00		Manufacturing of intermediate petrochemical products and petroleum products

- (i) During the period, Sinopec Corp acquired the entire 723,754,468 H shares, representing approximately 28.7% of the issued share capital of Sinopec Zhenhai at HK\$ 10.60 per share. The total consideration Sinopec Corp paid was approximately RMB 7,930 million which will be settled in cash. The excess of the cost of purchase over the carrying value of the underlying assets and

liabilities (on a proportionate share) was RMB 4,043 million, which was recorded as equity investment differences.

- (ii) During the period, Sinopec Corp acquired the shares not held by it in Sinopec Qilu, Sinopec Yangzi, Sinopec Zhongyuan and Dynamic of 17.71%, 14.83%, 28.50% and 71.38% respectively. The total consideration Sinopec Corp paid was approximately RMB 14,041 million which was settled in cash. The excess of the cost of purchase over the fair value of the underlying assets and liabilities (on a proportionate share) was RMB 7,766 million, which was recorded as equity investment differences.
- (iii) Sinopec Corp consolidated the results of the entity because Sinopec Corp controls the board of this entity and had the power to govern its financial and operating policies.

D. Property, Plants and Equipment.

Real Property

Our corporate headquarters and production facilities, occupying an area of approximately 7.03 square kilometers, are located in Jinshanwei, approximately 75 kilometers from downtown Shanghai. The total gross floor area of all our production and other facilities is approximately 2 million square meters. We own all of the buildings and facilities located at the site. We have the right to use the land upon which our buildings and facilities are located for a term of 50 years beginning in 1993 without the payment of any rent or usage fees other than land use taxes. We also have the right to transfer our land use rights to third parties without any payment to the Chinese government, so long as the use of the land remains the same as when the land use right was granted to us and the terms of the land use right we received will be applicable to any transferee.

Plants and Facilities

The following charts set forth the Rated Capacities of our principal production units. The actual production capacity of a production unit can exceed Rated Capacity and may be further increased without increasing the Rated Capacity through technical improvements or expansion of such unit. The utilization rate of a production unit is based upon Rated Capacity rather than actual production capacity and may vary with technical enhancements, changes in production management and scheduling of maintenance.

The following table sets forth the Rated Capacities and weighted average utilization rates of our principal production units for petroleum products and intermediate petrochemicals in 2006:

Production Unit (number of units)	Rated Capacity (tons)	Utilization Rate (%)
Crude oil distillation units (2)	14,000,000	60.25
Hydrocracker (2)	3,000,000	65.88
Ethylene units (2)	850,000	103.17
Aromatics unit	235,000	97.49
PTA unit	400,000	97.64
EO/EG unit	225,000	87.31
Acrylonitrile unit	130,000	103.80
Acetaldehyde unit	42,000	76.91
Acetic acid unit	45,000	47.44
Cracking and catalyzing	1,000,000	92.97
Delayed Coking	1,000,000	106.34

Our two crude oil distillation units were designed and built in China. In 2006, the actual amount of crude oil we processed was approximately 8.92 million tons. Our hydrocracker uses technology from United Oil Products Corporation of the United States. Our first ethylene unit uses technology from Mitsubishi Petrochemical Corporation of Japan. The second ethylene unit uses technology from ABB Lummus Global Inc. of the United States. The aromatics unit uses technology from Universal Oil Products Corporation of the United States. The PTA unit uses technology from Mitsui Petrochemical Corporation of Japan. The EO/EG unit was constructed using technology from Scientific Design Corporation of the United States.

The following table sets forth the Rated Capacities and weighted average utilization rates of our principal production units for resins and plastics and synthetic fibers in 2006:

Production Unit (number of units)	Rated Capacity (tons)	Utilization Rate (%)
Polyester units (3)	550,000	98.76
Polyester staple units (2)	154,000	81.71
Polyester filament units (3)	45,000	60.97

Acrylic staple fiber units (4)	191,000	111.19
Acrylic top units (2)	32,000	114.25
PE units (3)	408,000	106.28
PE film blowing facilities (2)	32,000	7.27
PP units (3)	400,000	108.91
PP staple fiber unit	17,000	0.85
PVA unit	86,000	110.00

Our polyester units use technology from Kanebo Corporation of Japan and E.I. Dupont DeNemours & Co. Inc. (“Dupont”) of the United States. The polyester staple units use technology from Teijin of Japan and Jima of Germany as well as Chinese technology. The polyester filament units use technology from Murata Manufacturing Company Limited and Teijin Corporation of Japan, Barmag AG of Germany and Dupont. We produce polyethylene in three units, two LDPE units which use technology from Mitsubishi Petrochemical Corporation of Japan and BASF LDPE of Germany and one HDPE unit uses the Borstar bimodal polyethylene technology from Northern European Chemical Engineering Company.

The acrylic fiber units were built domestically, based on a design of equipment which had been imported into China in the 1960s and that we substantially improved. In 1996, we acquired two additional acrylic fiber units which use technology from the Kawasaki Corporation of Japan. We produce PP in three identical units using technology from Himont Corporation of the United States. The PP staple fiber unit employs technology from FARE Company of Italy. The PVA unit uses technology acquired from Kuraray Corporation of Japan.

Power Facilities

Our electricity requirements are currently supplied by our own 275 megawatt oil-fired power plant, 225 megawatt coal-fired power plant and 100 megawatt coal-fired power plant and petroleum coke power plant. These power plants are designed to supply power sufficient for all of our facilities. We are connected to the East China electricity grid, which provides a back-up source of power in case of a shortfall in our power supply.

Other Facilities

We also have facilities to produce industrial water, steam, hydrogen, oxygen and nitrogen which we use in our production facilities.

Maintenance

We conduct a regular maintenance program on all production equipment. Maintenance is performed by Sinopec Group, as the successor to Sinopec, under a services agreement we entered into with Sinopec in March 1998. In addition, we employ approximately 4,010 engineers, technicians and other personnel who are employed by the various production units to perform day-to-day maintenance and repair.

Transportation-Related Fixtures

Crude oil, our principal raw material, is transported by pipeline to the coast and then by oil tanker to the oil terminal wharf at Chenshan. Our products leave the factory by water, rail, road and pipeline. In 2006, approximately 78.50% of our products by sales volume were collected by customers from our premises, and we delivered the balance. Our major ethylene customer is supplied via a pipeline. Some of the products collected by customers were also transported using our facilities.

Wharfs

We own two chemical wharfs at Jinshan with four berths of 3,000, 5,000, 10,000 and 25,000 tons. We also own a connecting pipeline capable of loading up to approximately 1.4 million tons of chemical products annually onto ocean-going barges and ships. In 2006, products representing 28.45% of total sales volume were shipped from the wharf. We also have a facility to load ships and barges which use the region's inland waterways. In 2006, products representing 21.24% of total sales volume were shipped from these facilities. We believe that we have a competitive advantage because a greater proportion of our products are shipped by water as opposed to rail and truck, which is subject to capacity constraints on China's rail and highway networks. Additionally, we own facilities for receiving crude oil and coal at docks that we own and transporting such materials by pipeline or conveyor to our production facilities.

We own an oil terminal wharf at Chenshan in Zhejiang Province, which is comprised of two berths, each of which is capable of handling 45,000 ton vessels. Two 25 kilometer pipelines connect this oil terminal wharf with our facilities.

Rail

We own a railroad loading depot with an annual capacity of 500,000 tons. The depot provides access via a spur line to the national Chinese railway system. In 2006, products representing 5.82% of total sales volume were transported from the factory by rail. Our ability to transport products by rail is limited because of China's overburdened railway system, the allocation of use of which remains strictly controlled by the Chinese government.

Capital Expansion Program

Our principal capital expansion projects for the near term are summarized in the table and further described below. In aggregate, we expect that total investment in the projects described will be approximately RMB2.5 billion in 2007. This amount will be funded internally and by bank loans.

<u>Name of Project</u>	<u>Rated Capacity (tons/year)</u>	<u>Start Date</u>	<u>Expected Completion Date</u>	<u>Status</u>
Refining Capacity Expansion				
3.3 million tons of diesel oil plus hydrogen refining device	3,300,000	2005	2007	Under construction
1.2 million tons of delayed coking unit	1,200,000	2006	2007	Under construction
Expansion of New and Existing Downstream Production Facilities				
380,000-ton EG Unit	380,000	2005	2007	Under construction
150,000-ton C ₅ Segregation Unit	150,000	2008	2008	Feasibility Study
Other Projects				
600,000 ton Aromatics Unit	600,000	2007	2008	Design
Flue Gas Desulphurization (“FGD ”)	N/A	2006	2007	Under construction
Expansion of No. 6 Power Generation Unit	N/A	2006	2007	Under construction
Upgrade of No. 2 ethylene unit SRT-III cracking furnace	N/A	2007	2007	Under construction

N/A – not applicable.

In 2004, 2005 and 2006, we invested RMB2.206 billion, RMB1.143 billion and RMB2.009 billion, respectively, in capital expansion projects.

Refining Capacity Expansion Plans

To accommodate the adjustment in our product mixes, to process the heavy and low-quality of crude oil we purchase in order to control our cost, and to enhance the quality of operations of oil refining facilities, we have started construction of a set of diesel oil plus hydrogen refining devices with Rated Capacity of 3.3 million tons per year and a set of 1.2 million tons of delayed coking unit. The construction of the diesel oil plus hydrogen refining devices commenced in 2005 and will be completed and delivered to operation in 2007.

Upon completion of the project, the quality of the diesel oil we produce can reach Europe III discharge standards, and is expected to reach Europe IV discharge standards after further renovation.

The construction of the delayed coking unit commenced in December 2006 and is anticipated to be completed and in operation by November 2007.

Expansion of New and Existing Downstream Petrochemical Products

As a fully integrated petrochemical complex, we produce a wide range of intermediate and downstream petrochemical products. We plan to further increase our production of higher-margin products by (i) adjusting our product mix, (ii) further processing existing products into higher-margin downstream products and (iii) adding new production capacity for higher-margin downstream products.

To increase production capacity for ethylene glycol, which is one of our higher-margin products, we have added a facility for producing ethylene glycol with 380,000 tons Rated Capacity. Construction commenced in 2005 and the facility commenced operation on March 3, 2007.

To take advantage of our strength in research, development and productions of C₅ chemical products, we plan to construct a 150,000-ton C₅ segregation unit. The construction of the project is anticipated to be completed in 2008.

Other Projects

To satisfy the demand of social and economic development of our country and to upgrade out-of-date devices and realize economies of scale and production, we are proposing to construct a new aromatics consolidation device with a Rated Capacity of 600,000 tons per year, which projects are expected to be completed in 2008. In order to improve energy efficiency and reduce material consumption, we plan to commence the upgrade of No. 2 ethylene unit SRT-III cracking furnace in July 2007, which is scheduled to be completed in 2007. To control and reduce the volume of sulphur dioxide emission to protect the environment, we plan to implement an FGD project with a capacity of 1 million cubic meters of flue gas per hour. To satisfy our further development and safeguard the balance of steam and power, we plan to expand the No. 6 power generation unit and construct a new 620-ton steam/hour boiler and the ancillary 100mw power generation unit project.

In addition to the foregoing projects, ongoing technological improvements and other small scale capital expansion projects, we are exploring expansion opportunities through acquisitions and other business combinations. We believe that acquisitions will become an increasingly important component of our expansion strategy.

ITEM 4A.UNRESOLVED STAFF COMMENTS.

Not applicable.

ITEM 5. OPERATING AND FINANCIAL REVIEW AND PROSPECTS

A. Operating Results.

General

Our financial performance has been affected by factors arising from operating in a planned economy which are beyond our control. However, with China's WTO accession, the impact of these factors has gradually been decreasing.

You should read the following discussion and analysis in conjunction with our audited financial statements and our selected financial data, in each case, together with the accompanying notes included elsewhere in this annual report. Our audited financial statements have been prepared in accordance with IFRS. IFRS differs in a number of significant respects from US GAAP. Note 34 to our audited financial statements, included elsewhere in this annual report, contains information relating to the nature and effect of significant differences between IFRS and US GAAP as they relate to us and provides a reconciliation to US GAAP of our net income and shareholders' equity.

Critical Accounting Policies

The following discussion and analysis of our financial condition and results of operations are based on our consolidated financial statements, which have been prepared in accordance with IFRS. The preparation of financial statements in conformity with IFRS requires management to make estimates and assumptions that affect the reported amounts of assets and liabilities and disclosure of contingent assets and liabilities at the date of the financial statements and the reported amounts of revenues and expenses during

2006. Our reported financial condition and results of operations are sensitive to accounting methods, assumptions and estimates that underlie the preparation of our financial statements. We based our assumptions and estimates on historical experience and on various other assumptions that we believe to be reasonable which form the basis for making judgments about matters that are not readily apparent from other sources. On an on-going basis, our management evaluates its estimates. Actual results may differ from those estimates as facts, circumstances and conditions change.

Our principal accounting policies are set forth in Note 2 to our consolidated financial statements. The selection of critical accounting policies, the judgments and other uncertainties affecting application of those policies and the sensitivity of reported results to changes in conditions and assumptions are factors to be considered when reviewing our financial statements. To enhance our readers' understanding of our business activities, we have identified critical accounting policies. We believe the following critical accounting policies involve the most significant judgments and estimates used in the preparation of our financial statements.

Impairment for long-lived assets

If circumstances indicate that the net book value of a long-lived asset may not be recoverable, the asset may be considered "impaired," and an impairment loss may be recognized in accordance with IAS 36 "Impairment of Assets". We review the carrying amounts of long-lived assets periodically in order to assess whether the recoverable amounts have declined below the carrying amounts. We test these assets for impairment whenever events or changes in circumstances indicate that their recorded carrying amounts may not be recoverable. When such a decline has occurred, the carrying amount is reduced to the recoverable amount. For goodwill, the recoverable amount is estimated annually. The recoverable amount is the greater of the net selling price and the value in use. It is difficult to precisely estimate selling prices because quoted market prices for our assets are often not readily available. In determining the value in use, we discount cash flows that we expect the asset to generate to their present value. Determining cash flows that we expect an asset to generate requires significant judgment in terms of projection of cash flows for future years and the assumption on the pre-tax discount rate that reflects current market assessments of the time value of money and the risks specific to the asset. We use all readily available information in determining an amount that is a reasonable approximation of recoverable amount, including estimates based on reasonable and supportable assumptions and projections of sale volume, selling price and operating costs.

Under US GAAP, we are required to record an impairment to write down an asset that is considered impaired to its estimated fair value. Such fair value is generally determined using the discounted cash flow method, which is similar to that used for determining the assets' value in use under IFRS. Under US GAAP, a long-lived asset, other than goodwill, that is held for use is considered impaired if its carrying value exceeds the estimated future undiscounted cash flows to be generated by that asset.

For the year ended December 31, 2006, RMB 50 million in impairment losses for long-lived assets of synthetic fiber segment (2005: nil; 2004: RMB 34 million) were recognized in our consolidated statements of income under both IFRS and US GAAP.

Depreciation

Property, plant and equipment are depreciated on a straight-line basis over the estimated useful lives of the assets, after taking into account their estimated residual value. We review the estimated useful lives of the assets regularly in order to determine the amount of depreciation expense to be recorded during any year. The useful lives are based on our historical experience with similar

assets and taking into account anticipated technological changes. The depreciation expense for future periods is adjusted if there are significant changes from previous estimates. There have been no significant changes to the original estimates of useful lives or residual values in 2004, 2005 and 2006.

Impairment for Bad and Doubtful Debts

We maintain an allowance for bad and doubtful accounts for estimated losses resulting from the inability of our customers to make the required payments. Our estimates are based on the aging of the trade debtor balance, customer credit-worthiness, and historical write-off experience. If the financial condition of our customers were to deteriorate, the amount of actual write-offs might be higher than what we expected.

The following table summarizes the changes in allowances for doubtful debts for the years ended December 31, 2004, 2005 and 2006:

	<u>Years ended December 31,</u>		
	<u>2004</u>	<u>2005</u>	<u>2006</u>
As of January 1,	39,811	45,282	25,845
Provision for the year	22,814	13,683	8,513
Written-off	(17,343)	(33,120)	(3,447)
December 31,	<u>45,282</u>	<u>25,845</u>	<u>30,911</u>

Summary

The following table sets forth our sales volumes and net sales, which is our sales less sales taxes, for the years indicated, presented in accordance with IFRS:

	<u>Years ended December 31,</u>								
	<u>2004</u>			<u>2005</u>			<u>2006</u>		
	<u>Net Sales</u>			<u>Net Sales</u>			<u>Net Sales</u>		
	<u>Sales Volume ('000 Tons)</u>	<u>(Millions of RMB)</u>	<u>% of Total</u>	<u>Sales Volume ('000 Tons)</u>	<u>(Millions of RMB)</u>	<u>% of Total</u>	<u>Sales Volume ('000 Tons)</u>	<u>(Millions of RMB)</u>	<u>% of Total</u>
Synthetic Fibers	384.4	4,751.8	12.3	355.2	4,764.0	10.6	337.0	4,711.7	9.4
Resins and Plastics	1,409.7	12,086.0	31.3	1,505.8	13,958.3	30.9	1,558.9	15,753.3	31.6
Intermediate									
Petrochemicals	1,075.8	5,896.6	15.3	1,010.5	6,556.0	14.5	1,009.3	6,775.7	13.6
Petroleum Products	4,828.9	13,101.9	33.9	5,400.0	17,955.0	39.7	5,109.8	19,387.6	38.8
All others	—	2,827.8	7.2	—	1,957.0	4.3	—	3,289.8	6.6
Total	<u>7,698.8</u>	<u>38,664.1</u>	<u>100.0</u>	<u>8,271.5</u>	<u>45,190.3</u>	<u>100.0</u>	<u>8,015.0</u>	<u>49,918.1</u>	<u>100.0</u>

The following table sets forth a summary statement of income ⁽¹⁾ for the periods indicated:

	Years ended December 31,					
	2004		2005		2006	
	Millions of RMB	% of Operating revenues	Millions of RMB	% of Operating revenues	Millions of RMB	% of Operating revenues
Synthetic fibers						
Operating revenues	4,778.0	12.1	4,781.8	10.4	4,727.3	9.3
Operating expenses	(4,527.6)	(11.5)	(4,518.4)	(9.8)	(4,531.0)	(9.0)
Operating profit	250.4	0.6	263.4	0.6	196.3	0.4
Resins and Plastics						
Operating revenues	12,154.4	30.8	14,010.3	30.5	15,800.0	31.2
Operating expenses	(10,267.8)	(26.0)	(12,519.6)	(27.3)	(14,637.9)	(28.9)
Operating profit	1,886.6	4.8	1,490.7	3.2	1,162.1	2.3
Intermediate Petrochemicals						
Operating revenues	5,941.6	15.1	6,586.5	14.3	6,800.6	13.5
Operating expenses	(4,390.8)	(11.1)	(5,605.5)	(12.2)	(6,120.2)	(12.1)
Operating profit	1,550.8	3.9	981.0	2.1	680.4	1.4
Petroleum products						
Operating revenues	13,692.4	34.8	18,616.5	40.5	19,977.8	39.5
Other revenues	—	—	632.8	1.4	282.1	0.6
Operating expenses	(12,705.8)	(32.3)	(19,696.2)	(42.9)	(21,957.6)	(43.4)
Operating profit/(loss)	986.6	2.5	(446.9)	(1.0)	(1,697.7)	(3.4)
All others						
Operating revenues	2,836.2	7.2	1,960.8	4.3	3,293.8	6.5
Operating expenses	(2,485.4)	(6.3)	(1,721.0)	(3.7)	(3,082.0)	(6.1)
Operating profit	350.8	0.9	239.8	0.6	211.8	0.4
Total						
Operating revenues	39,402.5	100.0	45,955.9	100.0	50,599.5	100.0
Other revenues	—	—	632.8	1.4	282.1	0.6
Operating expenses	(34,377.4)	(87.2)	(44,060.7)	(95.9)	(50,328.7)	(99.5)
Operating profit	5,025.2	12.8	2,528.0	5.5	552.9	1.1
Share of (losses)/ profits of associates and jointly controlled entities	(36.9)	(0.1)	(61.0)	(0.1)	576.7	1.1
Net financing costs	(292.0)	(0.7)	(179.4)	(0.4)	(165.4)	(0.3)
Income before tax	4,696.3	11.9	2,287.6	5.0	964.2	1.9
Income tax	(637.1)	(1.6)	(366.3)	(0.8)	(53.2)	(0.1)
Net income	4,059.2	10.3	1,921.3	4.2	911.0	1.8
Attributable to:						
Equity shareholders of the Company	3,971.1	10.1	1,850.5	4.0	844.4	1.7
Minority interests	88.1	0.2	70.8	0.2	66.6	0.1
Net income	4,059.2	10.3	1,921.3	4.2	911.0	1.8

(1) Operating revenues represent sales of the respective product segments without adjustment for sales tax. Operating expenses represent sales taxes and surcharges, cost of sales, selling and administration expenses and other operating expenses / (income), as allocated to respective product

segments. Operating profit corresponds to the profit from operating allocated to respective product lines.

Results of Operations

Year ended 31 December 2006 compared with year ended 31 December 2005.

Net sales

Total net sales increased by 10.46% to RMB49,918.1 million in 2006 as compared with RMB45,190.3 million in 2005. In 2006, demand for petrochemical products remained strong, driving product prices to rise continuously. However, the rise has since then slowed down remarkably. The weighted average prices of synthetic fibres, resins and plastics, intermediate petrochemicals and petroleum products for 2006 increased to varying degrees as compared to 2005.

(i) Synthetic fibres

Net sales of synthetic fibre products decreased by 1.10% to RMB4,711.7 million in 2006 as compared with RMB4,764.0 million in 2005. Although the weighted average price of synthetic fibres increased by 4.26%, the profit margin of synthetic fibre products was substantially reduced as the raw material costs of synthetic fibres increased further. Sales volume of synthetic fibres decreased by 5.14% as compared to 2005 because the sales volume of certain major synthetic fibre products, except industrial fibre and acrylic top, decreased by varying degrees.

Net sales of synthetic fibre products accounted for 9.44% of our total net sales in 2006, a decrease of 1.10 percentage points as compared to 2005.

(ii) Resins and plastics

Net sales of resins and plastics increased by 12.86% to RMB15,753.3 million in 2006 as compared with RMB13,958.3 million in 2005. Weighted average price of resins and plastics increased by 9.02% as compared to 2005 and sales volume increased by 3.52% as compared to 2005. Among our resins and plastics products for 2006, sales volume of polyester pellet, polyethylene and polypropylene increased by 7.10%, 5.04% and 1.66%, respectively, while the our average sales prices had increased by 4.12%, 11.49% and 9.85%, respectively.

Net sales of resins and plastics accounted for 31.56% of our total net sales in 2006, an increase of 0.67 percentage point as compared to 2005.

(iii) *Intermediate petrochemicals*

Net sales of intermediate petrochemicals increased by 3.35% to RMB6,775.7 million in 2006 as compared with RMB6,556.0 million in 2005, with weighted average price of intermediate petrochemicals increasing by 3.47% and sales volume decreasing by 0.11% as compared to 2005. Among our intermediate petrochemical products, the weighted average prices of our major products such as ethylene and butadiene increased by 15.09% and 7.40%, respectively, while the weighted average prices of pure benzene, ethylene glycol and ethylene oxide decreased by 6.87%, 7.62% and 11.86% respectively. The sales volumes of ethylene, butadiene, ethylene glycol and ethylene oxide decreased by 4.55%, 1.40%, 81.71% and 12.65%, respectively, except for pure benzene of which the sales volume increased.

Net sales of intermediate petrochemicals accounted for 13.57% of our total net sales in 2006, a decrease of 0.93 percentage point as compared to 2005.

(iv) *Petroleum products*

Net sales of petroleum products increased by 7.98% to RMB19,387.6 million in 2006 as compared with RMB17,955.0 million in 2005, with an increase of 14.11% in the weighted average price as compared to 2005. The weighted average prices of gasoline, diesel oil and jet fuel increased by 18.01%, 10.98% and 22.13%, respectively, but we reduced our sales volumes by 7.95%, 12.60% and 15.68%, respectively, subject to the requirement of Sinopec Corp., in light of the negative profit margin of petroleum products as a result of the price control of petroleum products by the State.

Net sales of petroleum products accounted for 38.84% of our total net sales in 2006, a decrease of 0.89 percentage point as compared to 2005.

We received a cash government grant of RMB282 million (2005: RMB633 million; 2004: nil) from the Ministry of Finance of the PRC as a compensation for loss incurred due to the distortion of the correlation of domestic refined petroleum product prices and crude oil prices in 2006. There are no unfilled conditions or other contingencies attached to the receipt or usage of this government grant. However, there is no assurance that we will continue to receive such grant in the future.

(v) *Trading and other activities*

Revenues for trading and other activities increased by 68.10% to RMB3,289.8 million in 2006 as compared with RMB1,957.0 million in 2005. Such increases in revenue were mainly attributed to increases in trading volume of our petrochemical products.

Operating Expenses

Our operating expenses comprise of sales taxes and surcharges, cost of sales, selling and administrative expenses, other operating expenses and other operating income.

Such operating expenses increased by 14.23% to RMB50,328.7 million in 2006 as compared with RMB44,060.7 million in 2005, mainly due to increase in international crude oil prices. The operating expenses of synthetic fibres, resins and plastics, intermediate petrochemicals, petroleum products, and trading and other activities amounted to RMB4,531.0 million, RMB14,637.9 million, RMB6,120.2 million, RMB21,957.6 million and RMB3,082.0 million, respectively, representing increases of 0.28%, 16.92%, 9.18%, 11.48% and 79.08%, respectively as compared to 2005.

(i) *Synthetic fibres*

Operating expenses of synthetic fibres increased by RMB12.6 million as compared to 2005, mainly due to an increase in raw material prices for synthetic fibres.

(ii) *Resins and plastics*

Operating expenses of resins and plastics increased by RMB2,118.3 million as compared to 2005, mainly due to increased costs for raw materials such as ethylene and propylene. Moreover, sales volume of polyester chips increased by more than 30,000 tons or 7.10% as compared to 2005, which also contributed to the increase in cost of sales and selling expenses of resins and plastics.

(iii) *Intermediate petrochemicals*

Operating expenses of intermediate petrochemicals increased by RMB514.7 million as compared to 2005, due to increased costs for raw materials such as naphtha.

(iv) *Petroleum products*

Operating expenses of petroleum products increased by RMB2,261.4 million as compared to 2005, mainly due to the continuous increase in crude oil price (which is a major production raw material for us), which has directly led to a significant increase in cost of sales and selling expenses of petroleum products.

(v) *Trading and other activities*

Operating expenses of trading and other activities increased by RMB1,361.0 million as compared to 2005, which was attributable to increased purchasing costs as a result of increased business volume.

Operating profit

Operating profit was RMB552.9 million, representing a significant decrease of 78.13% as compared with RMB2,528.0 million in 2005 primarily due to a significant increase in our production cost as a result of the rising crude oil price during 2006 while our petroleum product prices were subject to the State's control and were significantly below international prices.

(i) *Synthetic fibres*

Operating profit of synthetic fibres decreased by RMB67.1 million in 2006 as compared with 2005, mainly due to decrease of the sales volume of synthetic fibres by 5.14% in 2006 as compared with 2005.

(ii) *Resins and plastics*

Operating profit of resins and plastics decreased by RMB328.6 million in 2006 as compared to 2005, mainly due to increases in the cost of ethylene and propylene and other raw materials, which outweighed the price increase in resins and plastics.

(iii) *Intermediate petrochemicals*

Operating profit of intermediate petrochemicals decreased by RMB300.6 million in 2006 as compared to 2005, mainly due to increased costs for raw material, including naphtha.

(iv) *Petroleum products*

Petroleum products suffered operating loss, as the increase in average selling price of petroleum products was insufficient to offset the increase in average crude oil prices.

(v) *Trading and other activities*

Operating profit of trading and other activities decreased by RMB28.0 million in 2006 as compared with 2005.

Cost of sales

Cost of sales increased by 14.68% to RMB49,182.2 million in 2006, as compared with RMB42,887.7 million in 2005. Cost of sales accounted for 98.53% of the net sales for 2006, primarily due to a significant increase in 2006 in crude oil price which is our major raw material.

(i) *Crude Oil*

In 2006, we processed 8,920,300 tons of crude oil (of which 110,000 tons were processed on a sub-contracting basis), a decrease of 572,700 tons as compared with 9,493,000 tons in 2005 (274,000 tons of sub-contracting processing in 2005). The volumes of imported oil and offshore oil we processed were 8,572,000 tons and 348,300 tons, respectively.

The total cost of crude oil we processed in 2006 amounted to RMB33,307.6 million, an increase of 12.62% as compared with RMB29,576.4 million in 2005 and accounting for 67.72% of the cost of sales. Our weighted average cost of crude oil was RMB3,780.56 per ton, representing an increase of 17.84% as compared to 2005. The weighted average cost of imported oil and offshore oil was RMB3,787 per ton and RMB3,636 per ton, respectively.

(ii) *Other expenses*

Expenses for other ancillary materials were RMB7,901.8 million in 2006, an increase of 13.63% as compared with RMB6,954.0 million in 2005, primarily due to a significant increase in the purchasing costs of intermediate petrochemicals such as liquified petroleum gas and propylene during 2006. Depreciation expenses increased from RMB1,714.4 million in 2005 to RMB1,848.5 million in 2006. Energy and power costs increased to RMB974.8 million due to increases in coal prices and electricity tariffs in 2006. Compared to the same period of 2005, labor costs increased to RMB1,210.3 million during 2006, while maintenance costs decreased to RMB874.5 million.

Selling and administrative expenses

Selling and administrative expenses amounted to RMB522.0 million, representing an increase of 17.46% as compared with RMB444.4 million in the same period of the previous year due to the increase in our income from principal operations and our increase in marketing efforts during 2006.

Other operating income

Other operating income mainly includes income from joint ventures and other unlisted investments, rental income from investment properties and gain on disposal of fixed asset. Other operating income was RMB297.4 million in 2006, an increase of 24.64% as compared with RMB238.6 million in 2005, mainly due to the increase in income from fixed asset disposals and rental income from investment properties during 2006.

Other operating expenses

Other operating expenses mainly include employee reduction expenses, loss on disposal of property, plant and equipment and impairment loss on property, plant and equipment. Other operating expenses increased by 19.35% from RMB201.5 million in 2005 to RMB240.5 million in 2006, primarily due to the increase in expenses on net losses from fixed asset disposals and the provision made for impairments of fixed assets during 2006.

Share of profits of associates and jointly controlled entities

In 2006, share of profits of associates and jointly controlled entities was RMB576.7 million, representing an increase of RMB637.7 million against a loss of RMB61.0 million recorded in 2005, primarily due to the growth achieved by the 20% held investee, Secco. The Company's equity in Secco's loss for 2005 was RMB71.5 million compared to the Company's equity in Secco's net profit of RMB545 million. The results of Secco's operations are discussed in [Item 4. Information on the Company—Business Overview—Investments.](#)

Net financing costs

Our net financing costs were RMB165.4 million in 2006, a decrease of 7.80% as compared with RMB179.4 million in 2005, which was primarily due to a foreign currency exchange gain of RMB81.2 million recognized during 2006 as a result of the appreciation of RMB, thereby lowering our financing costs.

Income tax

Our income tax decreased to RMB53.2 million in 2006 as compared with RMB366.3 million in 2005. Such decrease was primarily due to a substantial decrease in total pre-tax profit. Our income tax decreased to RMB53.2 million in 2006 as compared with RMB366.3 million in 2005. Such decrease was primarily due to a substantial decrease in total pre-tax profit. Our effective tax rate was 5.5% in 2006 compared to 16.0% in 2005. The decrease in our effective tax rate is primarily due to our equity in earnings of Secco (whose results improved substantially over last year), which are not subject to income taxes.

We continued to pay income tax at a preferential rate of 15% in 2006. This preferential rate was first applied to us under the approval of the State's tax authorities which became effective from 1 January 1993. According to the relevant taxation regulations issued by the Ministry of Finance and the State Administration of Taxation, the first nine H-Share listed companies (including the Company) were permitted to pay income tax at a 15% tax rate for the years of 1996 and 1997. From 1998 to 2006, this tax privilege has not been revoked by the relevant government authorities. However, in March 2007, the National People's Congress passed legislation under which the same taxation system will be applied to both domestic enterprises and foreign enterprises. The enterprise income tax rate is unified at 25% and will be effective from 1 January 2008. The impact of such change of enterprise income tax rate on us will depend on implementation details, which will be issued later. See Item 3.D. Risk Factors—Changes in PRC tax laws may adversely affect our business and operating results.

Net Income

Net income was RMB911.0 million in 2006, a significant decrease of 52.59% as compared with RMB1,921.3 million in 2005.

Year Ended December 31, 2005 Compared with Year Ended December 31, 2004

Net sales

Total net sales increased by 16.88% to RMB 45,190.3 million in 2005 as compared with RMB 38,664.1 million in 2004. In 2005, the demand for petrochemical products remained strong causing product prices to increase. However, the rate of increase slowed significantly as compared with 2004. The weighted average prices of synthetic fibers, resins and plastics, intermediate petrochemicals and petroleum products for 2005 increased by varying degrees compared with 2004.

(i) Synthetic fibers

Net sales of synthetic fiber products increased by 0.26% to RMB 4,764.0 million in 2005 as compared with RMB 4,751.8 million in 2004. This slight increase resulted from an increase in the weighted average prices of 8.50%, offset by a decline in sales volume of 7.60%. Net sales of synthetic fiber products accounted for 10.54% of total net sales, a decrease of 1.75% as compared with 2004.

(ii) Resins and plastics

Net sales of resins and plastics increased by 15.49% to RMB 13,958.3 million in 2005 as compared with RMB 12,086.0 million in 2004. Weighted average prices increased by 8.12% and sales volume increased by 6.82% in 2005 as compared with 2004. Within this product category, the sales volume of polyester pellet, polyethylene and polypropylene increased by 20.29%, 2.88% and 2.12%, respectively, and the average sales price increased by 1.83%, 8.29% and 16.53% in 2005, respectively.

Net sales of resins and plastics accounted for 30.89% of our total net sales in 2005, a decrease of 0.37% as compared with 2004.

(iii) Intermediate petrochemicals

Net sales of intermediate petrochemicals increased by 11.18% to RMB 6,556.0 million in 2005 as compared with RMB5,896.6 million in 2004. Weighted average prices increased by 18.37% as compared with 2004. Sales volume decreased by 6.07% compared

with 2004. Among intermediate petrochemical products, the weighted average prices of our major products, ethylene, pure benzene, butadiene and ethylene oxide, increased by 2.88%, 7.43%, 37.36% and 16.81%, respectively. While the sales volumes of pure benzene, butadiene and ethylene oxide increased by 3.77%, 2.80% and 11.72%, respectively, the sales volume of ethylene decreased by 2.59%.

Net sales of intermediate petrochemicals accounted for 14.51% of our total net sales in 2005, a decrease of 0.72% compared with 2004.

(iv) Petroleum products

Net sales of petroleum products increased by 37.04% to RMB 17,955.0 million in 2005 as compared with RMB13,101.9 million in 2004, resulting from an increase of 22.55% in the weighted average price and 11.82% in sales volume of these products as compared with 2004. The weighted average price of gasoline, diesel oil and jet fuel increased by 28.30%, 21.69% and 29.00%, respectively, with sales volumes increasing by 20.94%, 11.96% and 13.18%, respectively.

Net sales of petroleum products accounted for 39.73% of total net sales in 2005, an increase of 5.84% compared with 2004.

(v) All others

Revenues for all other activities decreased by 30.79% to RMB 1,957.0 million in 2005 as compared with RMB 2,827.8 million in 2004.

Other Revenues

In 2005 we received a cash payment from the Ministry of Finance of the PRC of RMB 632.8 million as compensation for a distortion in the correlation of domestic refined petroleum product prices with crude oil prices during 2005. There are no unfilled conditions and other contingencies attached to the receipt or usage of this government grant.

Operating expenses

Operating expenses increased by 28.17% to RMB 44,060.7 million in 2005 as compared with RMB 34,377.4 million in 2004, mainly due to an increase in international crude oil prices. The operating expenses of resins and plastics, intermediate petrochemicals and petroleum products amounted to RMB 12,519.6 million, RMB 5,605.5 million and RMB19,696.2 million, respectively, representing increases of 21.93%, 27.66% and 55.02% as compared with 2004. Operating expenses of synthetic fibers and all others amounted to RMB 4,518.4 million and RMB 1,721.0 million, respectively, representing decreases of 0.20% and 30.76% as compared with 2004.

(i) Synthetic fibers

Operating expenses of synthetic fibers decreased by RMB 9.2 million in 2005 as a compared with 2004, mainly due to a decrease in sales volume of synthetic fibers of 7.60%.

(ii) *Resins and plastics*

Operating expenses of resins and plastics increased by RMB 2,251.8 million in 2005 as compared with 2004, mainly due to an increase in raw material costs of such products including ethylene and propylene. Sales volume of polyester chips increased by more than 70,000 tons or 6.81% as compared with 2004, another contributing factor to the rise in costs of sale and resins and plastics.

(iii) *Intermediate petrochemicals*

Operating expenses of intermediate petrochemicals increased by RMB 1,214.7 million compared with 2004, due to the raw material cost such as naphtha increased.

(iv) *Petroleum products*

Operating expenses of petroleum products increased by RMB 6,990.4 million compared with 2004, mainly due to the continuous increase in the price of crude oil, which directly led to a significant increase in the operating expenses of petroleum products. The weighted average cost of crude oil processed increased by 39.13% to RMB 3,208 in 2005 compared with RMB 2,306 in 2004.

(v) *All others*

Operating expenses of all other activities decreased by RMB 764.4 million in 2005 as compared with 2004. As the sales of ancillary materials decreased during the year, the related cost decreased accordingly.

Operating profit

Operating profit was RMB 2,528.0 million, a significant decrease of 49.69% compared with RMB 5,025.2 million in 2004, primarily due to a significant increase in the cost of production as a result of rising crude oil prices. The distorted correlation between international crude oil prices and domestic petroleum product prices which was subject to the State's control also led to a decrease in operating efficiency in 2005.

(i) *Synthetic fibers*

Operating profit of synthetic fibers increased by RMB 13.0 million in 2005 as a compared with 2004, mainly due to an increase in weighted average price of 8.30% only partially offset by an increase in the weighted average cost of 8.00% in 2005.

(ii) *Resins and plastics*

Operating profit of resins and plastics decreased by RMB 395.9 million in 2005 as compared with 2004, mainly due to increases in the cost of ethylene and propylene and other raw materials.

(iii) *Intermediate petrochemicals*

Operating profit of intermediate petrochemicals decreased by RMB 569.8 million in 2005 as compared with 2004, mainly due to increased costs for raw material, including naphtha.

(iv) *Petroleum products*

Petroleum products suffered an operating loss of RMB 446.9 million in 2005, as the increase in average selling price of petroleum products was insufficient to offset the increase in average crude oil prices. This increase was, however, partially mitigated by a subsidy payment received in 2005 from Ministry of Finance of the PRC amounting to RMB 632.8 million. The operating loss in 2005 compares to operating income of RMB 986.6 in 2004.

(v) *All others*

Operating profit of all other activities decreased by RMB 111.0 million in 2005 as compared with 2004.

Cost of sales

Cost of sales increased by 29.09% to RMB 42,887.7 million in 2005 from RMB 33,223.6 million in 2004 and accounted for 94.90% of the net sales for 2005. This increase was primarily due to a significant increase in the price of crude oil which was our major raw material.

(i) *Crude Oil*

In 2005, we processed 9,493,000 tons of crude oil (of which 274,000 tons were processed on a sub-contracting basis), an increase of 383,600 tons as compared with 9,109,400 tons in 2004 (602,500 tons of which was processed on a sub-contracting basis). The volume of imported oil and offshore oil we processed was 9,153,600 tons and 339,400 tons, respectively.

The total cost of crude oil processed in 2005 was RMB 29,576.4 million, an increase of 50.78% compared with RMB19,615.6 million in 2004, which accounted for 68.96% of the cost of sales. The weighted average cost of crude oil was RMB3,208.22 per ton representing an increase of 39.13% compared with 2004. The weighted averaged costs of imported oil and domestic offshore oil were RMB3,219 per ton and RMB 2,930 per ton, respectively.

(ii) *Other expenses*

Expenses for other ancillary materials was RMB 6,954.0 million in 2005, an increase of 14.16% compared with RMB6,091.6 million in 2004. This increase was primarily due to a significant increase in the purchasing costs of intermediate petrochemicals such as naphtha and acrylonitrile. Depreciation decreased from RMB 1,794.1 million in 2004 to RMB 1,705.1 million in 2005. Energy and power costs increased to RMB892.0 million due to an increase in the price of coal and electricity in 2005. Labor and maintenance costs decreased to RMB 1,168.5 million and RMB896.0 million, respectively, during the year.

Selling and administrative expenses

Selling and administrative expenses totaled RMB444.4 million in 2005, an increase of 8.90% compared with RMB408.1 million in 2004. Such increase was due to a significant increase in the income from principal operations compared with 2004.

Other operating income

Other operating income was RMB238.6 million in 2005, a decrease of 13.86% compared with RMB277.0 million in 2004.

Other operating expenses

Other operating expenses decreased by 29.10% from RMB 284.2 million in 2004 to RMB 201.5 million in 2005, primarily due to a decrease in loss on disposal of property, plant and equipment of RMB 41.5 million and impairment loss of property, plant and equipment of RMB 34.3 million.

Net financing costs

Net financing costs was RMB 179.4 million in 2005, a decrease of 38.56% compared with RMB 292.0 million in 2004, which was primarily due to a decrease in the balance of bank borrowings as compared with 2004, appreciation of RMB and realized foreign exchange gain of RMB 57.1 million.

Income tax

Income tax decreased by 42.51% to RMB 366.3 million in 2005 compared with RMB 637.1 million in 2004. This decrease was primarily due to a substantial decrease in total income. The effective tax rate (before tax refund) was 16.0% in 2005 as compared with 15.2% in 2004.

We continued to pay income tax at a preferential rate of 15% in 2005. This preferential rate was first applied to us under approval from State tax authorities effective from January 1, 1993. According to relevant taxation regulation issued by the Ministry of Finance and the State Administration of Taxation, the first nine H-Share listed companies (including the Company) were permitted to pay income tax at a 15% tax rate for years in 1996 and 1997. From 1998 to 2005, the tax privilege was not revoked by the relevant government authorities. However, we were unable to confirm whether the Ministry of Finance will maintain the 15% tax rate in 2006.

Net income

Net income was RMB1,921.3 million in 2005, a significant decrease of 52.67% compared with RMB4,059.2 million in 2004.

B. Liquidity and Capital Resources.

Our primary sources of liquidity historically have been from cash generated from operations and loans from unaffiliated banks. We believe, based on our credit history, that short-term credit from banks is readily available to us. In 2006 we also raised cash through the issuance of corporate bonds. Our primary uses of liquidity are for working capital, operating expenses, capital expenditures and repayment of loans. We believe our sources of liquidity are sufficient for our present requirements.

Cash flows provided from operating activities

Our net cash flow provided from operating activities amounted to RMB1,696.6 million in 2006, a decrease of RMB2,247.0 million as compared with RMB3,943.6 million in 2005. In addition to the decrease in our income before income tax in 2006, the follow factors contributed to the decrease in our operating cash flow:

- Increases in the year-end balances of debtors, bills receivables and deposits led to a decrease in operating cash inflow of RMB585.3 million in 2006 (as compared with an increase in cash inflow of RMB1,170.9 million in 2005 as a result of a decrease in such year-end balances), and

-
- Our share of Secco's income in 2006, which increased our income before tax without contributing any cash.

On the other hand, the following factors mitigated the decrease in our net operating cash flow in 2006:

- Increases in inventories balance at the end of 2006 led to cash outflows of RMB48.3 million in 2006, lower than the cash outflows of RMB387.2 million in 2005,
- Increases in the year-end amounts of operating payables, other payables and bills payable led to net cash inflows of RMB345.6 million in 2006, as compared with net cash outflows of RMB33.9 million in 2005, and
- Our income tax payment decreased significantly due to a significant decrease in net income during 2006. In 2006, income tax payment led to a cash outflow of RMB63.4 million, lower than the RMB431.0 million cash outflow in 2005.

Net cash used in investing activities

Net cash outflow for investing activities increased from RMB1,189.2 million in 2005 to RMB 1,352.5 million in 2006, mainly representing an increase in capital expenditures .

Cash flows used in financing activities

Net cash outflow used in financing activities decreased from RMB3,094.2 million in 2005 to RMB794.7 million in 2006, mainly representing an increase in the amount of financing through issuance of corporate bonds.

Borrowings

Our total borrowings in 2006 amounted to RMB5,334.0 million, representing a decrease of RMB70.0 million, of which short-term bank loans decreased by RMB669.8 million and long-term bank loans expiring within one year decreased by RMB956.6 million. On the other hand, we issued RMB2 billion short-term commercial papers to institutional investors within the PRC inter-bank debenture market in December 2006. The short-term commercial papers will mature on 12 December 2007. Short-term borrowings and loans were primarily used to meet our needs of working capital. Short-term bank loans carried floating interest rates denominated in Renminbi and short-term commercial papers carried an interest rate of 3.83%. During 2006, our long-term bank loans totalled an amount of RMB1,063.7 million, a decrease of RMB413.6 million. Most of our long-term bank loans were used for capital expansion projects for the past years.

We managed our asset-liability ratio by enhancing controls over both liabilities (including borrowings) and financing risks. We generally do not experience any seasonality in borrowings. Rather, due to the nature of the capital expenditures plan, long-term bank

loans can be arranged in advance of expenditures while short-term borrowings are used to meet operational needs. The terms of our existing borrowings do not restrict our ability to pay dividends on our shares.

Debt-equity ratio

Our debt-equity ratio was 5.3% in 2006 compared to 7.3% in 2005. The ratio is computed as follows: (total long-term loans)/(total long-term loans + shareholders' equity).

C. Research and Development, Patents and Licenses, etc.

We maintain a number of technology development units, including the Petrochemical Research Institute, the Polyester Fiber Research Institute, the Acrylic Fibre Research Institute and the Environmental Protection Research Institute. These units are charged with various research and development tasks with respect to new technology, new products, new production processes and equipment and environmental protection. Our research and development expenditures in 2004, 2005 and 2006 were RMB74.7 million, RMB79.5 million and RMB51.6 million, respectively, representing approximately 0.2%, 0.2% and 0.1% of the total sales, respectively, in those years.

We are not, in any material aspect, dependent on any patents, licenses, industrial, commercial or financial contracts or new production processes.

D. Trend Information

We believe that the ongoing global as well as domestic economic growth is set to provide the petrochemical industry with sound opportunities. According to the recent trends in the petrochemical market, the positive economic environment is expected to provide a stimulus for rapid growth in the demand for petrochemical products in 2007. Prices of major chemical products are generally rising, in tandem with the growth cycle of the petrochemical market. However, prices of domestic petrochemical products will also be subject to increased uncertainties and risks, such as the abolition of import quota for petroleum products for state-owned trading companies, continuous import tax reductions for certain types of petrochemical products and changes in state policies regarding export rebates that affect petroleum products. Cost of crude oil is, however, expected to remain high, creating significant challenges on our ability to maintain profit margins or even to remain profitable for certain products. As for market competition, we believe that major international players are preparing to enter the Chinese market amid industry restructuring on a global basis. Apart from posing direct competition against us in petroleum and petrochemical products, these international companies are characterized by large-scale investments across different sectors, full vertical integration and streamlined organization. Domestic companies are expected to face intense competition from their international counterparts as the China market becomes increasingly internationalized. In terms of our production operation, our production capacity will remain by and large the same, but the completion and operation of the Ningbo-Shanghai-Nanjing oil pipeline will bring about fundamental changes in the crude oil supply for us and lower transportation costs.

E. Off-balance Sheet Arrangements

As of December 31, 2006, our contingent liabilities amounted to RMB49.8 million in respect of guarantees issued to banks in favor of our associated companies and other unlisted investments, while such contingent liabilities as of December 31, 2005 were RMB68.3 million. Our guarantees issued to banks in favor of associated companies, other unlisted investments and subsidiaries are limited to the respective share in equity interest held by us. Please refer to Note 25(b) to our consolidated financial statements included in Item 18. Financial Statement for more detailed information on our guarantees and commitments.

F. Contractual Obligations and Commercial Commitments

The following table sets forth our obligations to make future payments under contracts effective as of December 31, 2006.

	As of December 31, 2006 Payment due by period				
	Total (RMB' 000)	Less than 1 year (RMB' 000)	1-3 years (RMB' 000)	4-5 years (RMB' 000)	More than 5 years (RMB' 000)
Contractual obligations					
Short-term loan	1,853,692	1,853,692	—	—	—
Long-term loan	1,480,299	416,645	1,033,931	29,723	—
Corporate bonds	2,000,000	2,000,000	—	—	—
Total contractual obligations	<u>5,333,991</u>	<u>4,270,337</u>	<u>1,033,931</u>	<u>29,723</u>	<u>—</u>
Estimated future interest payments					
Fixed rate	303,585	173,336	130,249	—	—
Variable rate	<u>34,486</u>	<u>34,486</u>	—	—	—
Total estimated future interest payments	<u>338,071</u>	<u>207,822</u>	<u>130,249</u>	<u>—</u>	<u>—</u>
Other commercial commitments					
Capital commitment (note)	2,459,995	2,459,995	—	—	—
Total commercial commitments	2,459,995	2,459,995	—	—	—

Note: Capital commitments refer to commitments for purchase of property, plant and equipment and investment.

G. Other Information

Employees

Our staff costs for 2006 were RMB1,210.3 million.

Capital Expenditures

In 2006, our capital expenditures amounted to RMB2,008.8 million, representing an increase of RMB865.9 million as compared with RMB1,142.9 million in 2005. The expenditures in 2006 were for the following projects:

<u>Project</u>	<u>Total Investment</u> RMB' 000	<u>Progress</u>
380,000 tons/year glycol facilities	1,249,000	in progress
3,300,00 tons/year diesel hydrogenation project	528,000	in progress
Total	<u>1,777,000</u>	

The estimated capital expenditure for 2007 is RMB 2,500 million, mainly for the construction of projects in progress such as the 1.2 million-ton delayed coking unit, expansion of the No. 6 power generation unit, the 6,000,000-ton Aromatics Unit, the 380,000-ton per year ethylene glycol facility and the 3,300,00 tons/year diesel hydrogenation project, and preparatory work related to other technological renovation projects.

Purchase, Sale and Investment

Except as disclosed in this report, during the year 2006, we engaged in no material purchase or sale of our subsidiaries or associated companies or any other material investments.

Pledge of Assets

As of December 31, 2006, we have not pledged any of our property or equipment.

U.S. GAAP Reconciliation

The financial statements have been prepared in accordance with IFRS. IFRS vary in certain significant respects from U.S. GAAP. Information relating to the nature and effect of such differences is presented in Item 18. Financial Statements—Consolidated Financial Statements—Note 34.

ITEM 6. DIRECTORS, SENIOR MANAGEMENT AND EMPLOYEES.

A. Directors and Senior Management.

The following table sets forth certain information concerning our directors, executive officers and members of our supervisory committee (“Supervisory Committee”). The current term for our directors, executive officers and members of our Supervisory Committee is three years, which term will end in June 2008.

<u>Name</u>	<u>Age</u>	<u>Position</u>
<u>Directors</u>		
Rong Guangdao	51	Chairman of the Board of Directors and President
Du Chongjun	52	Vice Chairman of the Board of Directors and Vice President
Han Zhihao	55	Director and Chief Financial Officer

Li Honggen	51	Director and Vice President
Dai Jinbao	51	Director
Shi Wei	47	Director and Vice President
Lei Dianwu	44	External Director
Xiang Hanyin	52	External Director
Chen Xinyuan	42	Independent Director
Sun Chiping	48	Independent Director
Jiang Zhiquan	56	Independent Director
Zhou Yunnong	64	Independent Director
<u>Other Executive Officers</u>		
Zhang Jianping	44	Vice President
Tang Chengjian	51	Vice President
Zhang Jingming	49	Secretary of the Company
<u>Supervisory Committee</u>		
Gao Jinping	40	Chairman of the Supervisory Committee
Zhang Chenghua	51	Supervisor
Wang Yanjun	46	Supervisor
Geng Limin	52	External Supervisor
Lü Xiangyang	54	External Supervisor
Liu Xiangdong	55	Independent Supervisor
Yin Yongli	67	Independent Supervisor

Directors

Rong Guangdao, 51, is the Chairman and President of the Company. Mr. Rong joined the Complex in 1973 and has held various positions, including Deputy Director of the No.1 Chemical Plant and Deputy Director and Director of the Ethylene Plant. In April 1994, he was appointed Vice President of the Company and responsible for production and planning. In June 1995, he was elected as a Director of our Company. In October 2003, Mr. Rong was appointed the President of the Company. In May 2004, Mr. Rong was elected the Chairman of the China Jinshan Associated Trading Corporation. In June 2004, Mr. Rong was elected as Vice Chairman of the Board of Directors of our Company. Mr. Rong has many years of experience in organizing and directing large scale petrochemical production and human resource development. In 1985, Mr. Rong graduated from the Automated Instrument Department of the Shanghai Petrochemical College for Workers and Staff Members. In 1997, he obtained an MBA from China Europe International Business School. He is a senior engineer.

Du Chongjun, 52, is the Secretary of the Communist Party Committee, Vice Chairman and Vice President of the Company. He joined the Complex in 1974 and has held various positions, including General Manager, Secretary and Deputy Secretary of the Communist Party Committee of the Acrylic Fibre Plant of the Complex, General Manager and the Secretary of the Communist Party Committee of Shanghai Jinyang Acrylic Fibre Plant and General Manager of the Acrylic Business Division of our

company. In May 1999, he became the Deputy Secretary of the Communist Party Committee and the Secretary of the Communist Party Discipline

Supervisory Committee. From June 1999 to June 2004, he was the Chairman of the Supervisory Committee of the Company. In October 2003, he was appointed the Secretary of the Communist Party Committee. In June 2004, Mr. Du was appointed the Vice Chairman of the Board of Directors of the Company. Mr. Du has extensive experience in large scale enterprise operation, management and internal supervision. Mr. Du graduated in enterprise management from East China Institute of Chemical Technology in 1986. In 1999, Mr. Du graduated in computer application management from Shanghai Second Polytechnic University. He is a senior economist.

Han Zhihao, 55, is an Executive Director and the Chief Financial Officer of the Company. Mr. Han joined the Complex in 1976 and has held various positions including Deputy Director of the Vehicle Transportation Department, Deputy Director and Director of the Finance Department of the Complex, Director of the Finance Department and Deputy Chief Accountant of our Company. In 1998, he became Chief Accountant of our Company. In October 2003, he became our Chief Financial Officer. In June 2004, he was elected to serve as one of our Directors. He graduated from Shanghai University of Finance and Economics with a major in financing and accounting (self studies) in 1990. He obtained an MBA from East China University of Science and Technology—University of Canberra in Australia in 2002. Mr. Han is a senior accountant.

Li Honggen, 51, is an Executive Director and Vice President of the Complex. Mr. Li joined the Company in 1973 and has held various positions including Deputy Director of No. 1 Chemical Plant of the Company, Deputy Director and Director of the Ethylene Plant of the Company and Deputy Manager and Manager of the Refining and Chemical Division of the Company. In August 2000, he was appointed as Vice President of Shanghai Chemical Industrial Park Development Company Limited. In March 2006, he became Vice President of the Company. Mr. Li graduated from East China University of Science and Technology in 1998. He is an engineer.

Dai Jinbao, 51, is an Executive Director and a Deputy Secretary of the Communist Party Committee of the Company's Refining and Chemical Division and Chairman of the Labor Union. Mr. Dai joined the Complex in November 1973 and was Deputy Director of No.1 Chemical Plant of the Company. In December 1997, he was appointed as Director of ethylene joint production facilities of No.1 Refining and Chemical Division of the Company. In May 2003, he was appointed as Chairman of the Labor Union of the Company's Refining and Chemical Division. Mr. Dai graduated from the Shanghai Second Polytechnic University majoring in business management. He is a certified engineer.

Shi Wei, 47, is an Executive Director and Vice President of the Company. Mr. Shi joined the Complex in 1982 and was appointed as Assistant to the Manager of the Refining and Chemical Division in May 1996, Deputy Manager of Refining and Chemical Division in October 1997, Manager of the Environment Protection Division of the Company in March 1999, Secretary of the Communist Party Committee of the Refining and Chemical Division in April 2001, Manager of the Refining and Chemical Division in July 2002, and Vice President of the Company in October 2003. Mr. Shi graduated from the Eastern China Petrochemical Institute specializing in oil refinery engineering in 1982, and completed the postgraduate course on business administration in Eastern China University of Science and Technology in 1998. He is a qualified senior engineer.

External Directors

Lei Dianwu, 44, is currently the Director of the Department of Development and Planning of Sinopec Corp. Since June 2005, he has served as an External Director of the Company. Mr. Lei, previously served as the Vice Division Chief of Overall Planning Department of Yangzi Petrochemical Company Limited, the Head of the Affairs Office of the Yangzi Petrochemical joint venture, the Deputy General Manager and General Manager of Production Department of Yangzi-BASF Styrenics Co., Ltd.; the Deputy General

Manager and Deputy Division Chief of the Co-operation Office of Yangzi Petrochemical Company Ltd.; the Division Chief of Planning and Development Department of China Donglian Petrochemical Company Ltd.; the Deputy General Manager of Yangzi Petrochemical Company Ltd.; the Deputy Division Chief of the Development and Planning Department of Sinopec Corp. As of March 2001, Mr. Lei became the Division Chief of Department of Development and Planning of Sinopec Corp. Mr. Lei has extensive experience in enterprise planning and investment development management. In 1984, Mr. Lei graduated from Eastern China Petroleum Institute, specializing in organic chemistry. He is a qualified senior engineer.

Xiang Hanyin, 52, is currently the Deputy Division Chief of Chemistry Industry Department of Sinopec Corp. He became an External Director of the Company in June 2005. Beginning his career in February 1982, Mr. Xiang has served in various positions including as Vice Chairman of Yizheng Chemical Fiber Company and Chairman of the Chemical Factory of Yizheng Chemical Fiber Corporation Ltd. In February 2000, Mr. Xiang was appointed as the Deputy Division Chief of the Chemistry Industry Department of Sinopec Corp. Mr. Xiang has extensive experience in chemistry enterprise production and operation management. He graduated from Nanjing Institute of Chemical Technology, specializing in basic organic chemical technology in 1982 and completed his postgraduate studies on enterprise administration in Nanjing University in 2000. He is a qualified senior engineer.

Independent Directors

Chen Xinyuan, 42, currently the Dean and Professor of the College of Accounting of the Shanghai University of Finance and Economics, was elected as an Independent Director of our company in June 2003. Between June 2000 and June 2003, he was an Independent Supervisor of our company. After graduation from the Accounting Faculty of Hangzhou College of Commerce in July 1985, Mr. Chen undertook graduate studies at the Accounting Faculty of Shanghai University of Finance and Economics. He commenced his doctoral studies in accounting while teaching and received his doctorate in June 1994. He has been a tutor to doctoral students since December 1998. Mr. Chen has also studied in West Germany for one year. He is very familiar with financial accounting, given his experience in the academic aspects of accounting and notable achievements in accounting research. He is also experienced in business management.

Sun Chiping, 48, currently the Head of Shanghai branch of the Industry and Commercial Bank of China and the Secretary of the Communist Party Committee, was elected as an Independent Director of our company in June 2005. Mr. Sun began his banking career March 1979 and has served in various positions including as an accountant; the Deputy Division Chief of Huangpu, Jingan sub-branch of Shanghai branch of People's Bank of China; the Vice Secretary of the Communist Party Committee of Industry and Commercial Bank of China Shanghai branch; Deputy Chief, Head, Vice Secretary of the Communist Party Committee of Xuhui sub-branch of Shanghai branch of Industry and Commercial Bank of China; General Manager of the International Business Department of Industry and Commercial Bank of China Shanghai branch; Assistant Head and General Manager of the International Business Department of Industry and Commercial Bank of China Shanghai branch, and Vice Head of the Industry and Commercial Bank of China Shanghai branch. He has also previously served as Vice Head, Head and Secretary of the Communist Party Committee of Industry and Commercial Bank of China Guangdong branch. Mr. Sun graduated from Shanghai Finance and Economy University, specializing in finance. He obtained a master degree in economics and an MBA from the Shanghai Finance and Economy University, Hong Kong/Fudan University MBA program. He has extensive experience in banking and finance and is a senior economist.

Jiang Zhiquan, 56, currently a Secretary of the Communist Party Committee and chairman of the Shanghai Jiangong Group, was elected as an Independent Director of our company in June 2005. Mr. Jiang began his career in December 1968 and has served in various positions including Deputy Division Chief of Shanghai Jiangong Bureau; General Manager of Shanghai No. 4 Construction Company; Vice Secretary of the Communist Party Committee of Shanghai Construction and Engineering Management Bureau; Vice Secretary of the Communist Party Committee; Vice Chairman and General Manager of Shanghai Jiangong Group; and Secretary of the Communist Party Committee and Chairman of Shanghai Jiangong Group. Mr. Jiang has extensive experience in business strategy and management of large group companies. Mr. Jiang graduated with an MBA from the Hong Kong/Fudan University MBA program. He is a senior economist.

Zhou Yunnong, 64, is a former Governor of Shanghai Jinshan District and Member of the Leaders Group of Shanghai Chemical and Industrial Park. He currently serves as a Senior Advisor of Jinshan Industrial Investment and Development Company. In August 1964, Mr. Zhou graduated from Eastern China Normal University majoring in radio. He joined the Complex in October 1972, and was appointed the Vice President of the Complex in August 1984. From June 1989 to August 1991, Mr. Zhou served as Deputy Director of the Human Resource Department of Sinopec. In August 1991, Mr. Zhou was appointed as the Deputy Secretary of Communist Party Committee of the Complex, and appointed as the Vice President of the Complex in March 1992. From July 1993 to April 1994, Mr. Zhou served as a vice president in charge of administration and human resources for our company. In April 1994, Mr. Zhou was appointed the Secretary of the Communist Party Committee of JI. He served as Governor to Jinshan District of Shanghai from May 1997 to November 1999. Mr. Zhou has the title of senior engineer and he has rich experience in business management.

Supervisory Committee

The Company has a Supervisory Committee whose primary duty is to supervise senior management of the Company that includes the Board of Directors, managers and senior officers. The function of the Supervisory Committee is to ensure that senior management of the Company act in the interests of the Company, its shareholders and employees and in compliance with PRC law. The Supervisory Committee reports to the shareholders in the general meeting. The Articles of Association provide the Supervisory Committee with the right to investigate the business and the financial affairs of the Company and to convene shareholder's meetings from time to time. The Supervisory Committee currently comprises of seven members, two of whom are employee representatives and five of whom are external supervisors, including two independent supervisors.

Gao Jinping, 40, serves as a Deputy Secretary of the Communist Party Committee and Chairman of the Trade Union of the Company. Mr. Gao joined the Complex in 1990 and has held various positions including Deputy Secretary of the Communist Youth League, Deputy Secretary of the Communist Party Committee of the Experimental Plant and Petrochemical Business Department of the Company and the Director of the Propaganda Division of our company. In May 2003, Mr. Gao was appointed as Deputy Secretary of the Communist Party Committee and Chairman of the Trade Union of the Company. In June 2004, Mr. Gao was elected as Director of our company. In June 2006, Mr. Gao was elected as the Chairman of the Supervisory Committee of the Company. Mr. Gao graduated from the Food Processing Faculty of Shanghai Aquatic Products University with a major in cooling and cold storage technology and obtained a bachelor's degree in engineering in July 1990. In 2001, he completed his post-graduate industrial economics studies at Shanghai Academy of Social Sciences. He has a senior professional technical qualification.

Zhang Chenghua, 51, is a Deputy Secretary of the Communist Party Discipline Supervisory Committee and the Director of the

Supervision Office. He joined the Complex in 1974 and held various positions, including a Deputy Secretary of the Communist Party Committee and the Secretary of the Communist Party Discipline Supervisory Committee, as well as Chairman of the Trade Union of the Thermoelectricity Plant of the Complex (subsequently known as the Thermoelectricity Plant of Shanghai Petrochemical Company Limited). Mr. Zhang has rich experience in management of enterprises and trade unions. In January 1999, Mr. Zhang graduated from Shanghai Municipal Communist Party School with a specialization in Communist Party political management. He also finished postgraduate study of industrial economy in Shanghai Social Science Academy in June 2001. He is a qualified engineer.

Wang Yanjun, 46, currently serves as a supervisor and Vice-Chairperson of the labor union of our company. Ms. Wang joined our company in July 1982. She was appointed as Chairperson of the labor union of Shanghai Petrochemical Plastics Company in January 1999; was appointed as Chairperson of the labor union of Chemical Department of our company in June 2002 and appointed as a Secretary of the Communist Party Committee and Chairperson of the labor union of Chemical Department of our company in July 2004. She was elected to serve as an Independent Director of our company in June 2005. Ms. Wang graduated from East China University of Science and Technology specializing in organic chemistry in July 1982 and completed her postgraduate studies in the Shanghai Academy of Social Sciences MBA program in 2001. Ms. Wang has a senior professional technical qualification.

External Supervisors

Lü Xiangyang, 55, is a Vice Director of the Auditing Bureau of Sinopec Group and was appointed our Supervisor in June 2002. He joined Qianguo Oil Refinery in 1970 and had held various positions there, including Deputy Director and Director of the Financial Department. He has served as the Deputy Director of the Production Auditing Division of the Auditing Department of Sinopec since 1992 and served as the Deputy Director of the Auditing Bureau of Sinopec and Sinopec Group since 1997. Mr. Lü had also held positions as the Director of Production Auditing Department and Deputy Manager of Sinopec Huxia Auditing Company. He has rich experience in management in the fields of finance and auditing. He graduated in 1985 from the Xi'an College of Petroleum Industry and has the title of accountant.

Geng Limin, 52, is currently Vice Head of the Department of Supervision of Sinopec, Sinopec Group and Sinopec Corp. He was appointed as an Independent Director of our company in June 2005. Mr. Geng started his career in 1971 and has held the positions of Deputy Division Chief of the Human Resources and Education Departments of Sinopec and Division Chief of the Human Resources and Education Departments of Sinopec Group. Mr. Geng graduated from Daqing Employee's College in 1981, specializing in English in 1981 and completed his postgraduate studies in law from Beijing Renwen University. He is a qualified translator.

Independent Supervisors

Liu Xiangdong, 55, is currently the President of Zhengda International Finance Corporation. He was appointed our independent supervisor in June 2000. Mr. Liu has held the positions of planning and credit officer and deputy head and head of the credit division of several banks. He has also been Deputy Chief and Chief of the Planning Department of the Industrial and Commercial Bank of China, Shanghai Branch. He became Chief Economist and concurrently the Director of the Planning Division of the Industrial and Commercial Bank of China, Shanghai Branch in August 1996. He has been Deputy Director of the Industrial and Commercial Bank of China, Shanghai Branch since October 1997, and began to serve as General Manager of the Investment Bank Division of the Industrial and Commercial Bank of China from June 2002. Mr. Liu is a veteran in the banking sector with extensive experience in management and other practical aspects of the business. He holds a master's degree in economics and the title of senior economist.

Yin Yongli, 67, is currently the Chairman of Tianhua Accounting Firm. He was appointed as an Independent Director of our company in June 2005. Mr. Yin has acted as Deputy Division Chief, Division Chief of Shandong Sheli Refinery Oil Company, Deputy Chief Financial Officer of Qilu Petrochemical Company, Chief Financial Officer of Sinopec, Chief Financial Officer and Deputy Chief of the Accounting Department of Sinopec and Assistant Manager of Shihua Auditing Firm. He was appointed as Chairman of Zhong Rui Hua Heng Accounting Firm in September 2001, Chairman of Hua Zheng Accounting Firm in June 2004 and Chairman of Tianhua Accounting Firm in June 2005. Mr. Yin has extensive financing and auditing experience. He graduated from the Shandong College of Finance and Economics in 1964 and holds the title of senior accountant and CPA.

Senior Management

Zhang Jianping, 44, is a Vice President of the company. He joined the Complex in 1987, and successively held the positions of Vice Chief Engineer of Oil Refining Chemical Department Arene Factory, Vice Director of the Plastic Factory, Deputy Manager of Plastics Department of Shanghai Petrochemical, Director of the Chemical Institute, Director of Production Department of Shanghai Petrochemical. In February 2002, he became the assistant to the President of our company and Director of Production Department. In July 2004, he was appointed Vice President of our company. Mr. Zhang graduated from East China Chemical Institute specializing in Petroleum Refinery and received a Master's Degree in Petroleum Processing from the same school in 1987. He is a qualified senior engineer.

Tang Chengjian, 51, is a Vice President of our company. He joined the Complex in 1974, and successively held the positions of Deputy Secretary of Communist Party Committee, Trade Union Director, Deputy Director and Director of Thermal Power Factory at the Complex. He was appointed the Vice President of our company in July 2004. Mr. Tang graduated from Shanghai Power Technology School with a specialization in power plant steam turbines; received a graduate diploma from Shanghai Power College in power plant and power systems; received a bachelor degree from Shanghai No. 2 Industry University in project management; and a MBA from China Europe International Industrial and Commercial Institute in 2001. He is a qualified engineer.

Zhang Jingming, 49, is the Secretary of the Board, General Legal Counsel, the Director of the Secretariat Office to our Board of Directors and Director of Strategy Research Office of our company. Mr. Zhang joined the Complex in 1978. Mr. Zhang has held various positions including Project Manager and Deputy Director of the International Department and our representative in Hong Kong. Mr. Zhang is fluent in English with special expertise in interpretation and translation of petrochemical engineering documents. Mr. Zhang participated in the technology exchange, agreement negotiation, project construction and technical trainings of the Complex's Phase II & III projects. He is experienced in communication with foreigners and introduction of enterprise to others. In 1995, Mr. Zhang received an MBA from the University of Hull in the UK. He is a qualified senior economist.

B. Compensation.

The aggregate amount of cash compensation we paid to our directors, supervisors and executive officers during the year ended December 31, 2006 was approximately RMB4.339 million. In addition, directors and supervisors who are also officers or employees receive certain other benefits-in-kind, such as subsidized or free health care services, housing and transportation, which large Chinese enterprises customarily provide to their employees. No benefits are payable to members of the board or the Supervisory Committee or the executive officers upon termination of their relationship with us.

The following table sets forth the compensation on an individual basis for our directors, supervisors and executive officers who received compensation from us in 2006.

<u>Name</u>	<u>Position with the Company</u>	<u>Remuneration in 2006 (RMB' 000)</u>
Rong Guangdao	Chairman of the Board of Directors and President	456
Du Chongjun	Vice Chairman of the Board of Directors and Vice President	456
Han Zhihao	Director and Chief Financial Officer	396
Shi Wei	Director and Vice President	387
Li Honggen	Director and Vice President	355
Dai Jinbao	Director	183
Lei Dianwu	External Director	0
Xiang Hanyin	External Director	0
Chen Xinyuan	Independent Director	80
Sun Chiping	Independent Director	80
Jiang Zhiquan	Independent Director	80
Zhou Yunnong	Independent Director	80
Gao Jinping	Chairman of the Supervisory Committee	386
Zhang Chenghua	Supervisor	214
Wang Yanjun	Supervisor	196
Lu Xiangyang	External Supervisor	0
Geng Limin	External Supervisor	0
Liu Xiangdong	Independent Supervisor	0
Yin Yongli	Independent Supervisor	0
Zhang Jianping	Vice President	370
Tang Chengjian	Vice President	380
Zhang Jingming	Company Secretary and Corporate Counselor	240

C. Board Practices.

Board of Directors

Our board of directors consists of twelve members. Our directors are elected at meetings of our shareholders, and, unless they resign at an earlier date, are deceased or removed, will serve three-year terms. The term of our current board of directors will expire in June 2008. None of our directors, have entered into any service contracts with us or any of our subsidiaries providing for benefits upon termination of appointment or employment.

Supervisory Committee

The Supervisory Committee is responsible for ensuring that our directors and senior officers act in the interests of our company or those of our shareholders or employees and that they do not abuse their positions and powers. The Supervisory Committee has no power to overturn the decisions or actions of our directors or officers and may only recommend that they correct any acts that are harmful to our interests or the interests of our shareholders or employees. The Supervisory Committee is currently composed of seven

members appointed for a three year term. The term of the current members will expire in June 2008. Supervisory Committee members have the right to attend meetings of our board of directors, inspect our financial affairs and perform other supervisory functions.

Audit Committee

Pursuant to Paragraph 14 of the Code of Best Practices set out in Appendix 14 of the Rules Governing the Listing of Securities on The Stock Exchange of Hong Kong Ltd, we formed an audit committee on June 15, 1999 which consists of three directors. The current members are Chen Xinyuan, Zhou Yunnong and Sun Chiping. The principal duty of the audit committee is to review and supervise our financial reporting process and internal controls. The members of the audit committee will hold office for the same term as their directorships which will expire in June 2008.

Remuneration Committee

We formed a remuneration committee on December 25, 2001 which consists of three directors. The current members are Dai Jinbao, Chen Xinyuan and Zhou Yunnong. The key responsibility of the Remuneration Committee is to formulate and review the remuneration policy and plan for the directors and executive officers, formulate the standards for evaluation of the directors and executive officers and conduct such evaluations.

Summary Corporate Governance Differences

There are significant differences between our corporate governance practices and those of U.S. issuers listed on the New York Stock Exchange. Pursuant to Section 303A.11 of the NYSE listing Manual, we have disclosed certain of these differences on our website at www.spc.com.cn/enspc/spc/newsroomlook.php?Did=1650&cid=69dD1ev=5.

D. Employees.

As of December 31, 2006, we had 22,922 employees.

The following table shows the approximate number of employees we had at the end of our last three years by the principal business function they performed:

	December 31,		
	2006	2005	2004
Management	1,580	2,004	2,395
Engineers, technicians and factory personnel	14,163	16,427	20,343
Accounting, marketing and other	7,179	7,050	5,713
Total	<u>22,922</u>	<u>25,481</u>	<u>28,451</u>

Approximately 27.6% of our work force graduated from university or technical colleges. In addition, we offer our employees opportunities for education and training based upon our development and the individual performance of each employee.

We have completed implementing a system of labor contracts. The contract system imposes discipline, provides incentives to adopt better work habits and gives us greater management control over our work force. We believe that by linking remuneration to productivity, the contract system has also improved employee morale. As of December 31, 2006, almost all of the work force was employed pursuant to labor contracts which specify the employee's position, responsibilities, remuneration and grounds for

termination. The contracts generally have terms of five years and may be renewed with the agreement of both parties. The personnel who have worked in SPC for over ten years may enter into labor contracts with an indefinite term.

We have a trade union that protects employees' rights, aims to assist in the fulfillment of our economic objectives, encourages employee participation in management decisions and assists in mediating disputes between us and union members. We have not been subject to any strikes or other labor disturbances which have interfered with our operations, and we believe that our relations with our employees are good.

Total remuneration of our employees includes salary and bonuses. Employees also receive certain benefits in terms of housing, education and health services that we subsidize, and other miscellaneous subsidies. In 2006, we paid RMB1,210 million in employment costs.

In compliance with Shanghai regulations, we and our employees participate in a defined contribution government pension scheme under which all employees upon retirement are entitled to receive pensions. Pursuant to government regulations, we established a supplementary defined contribution retirement scheme for all employees in 1995. This scheme provides for a supplementary pension funded by voluntary payments by employees that are matched by payments we make. Each year's level of matching payments is based upon our profitability and the employee's performance and attitude. The supplementary pension is intended to provide a further incentive to employees.

We do not carry worker's compensation or other similar insurance. However, all employees (both contract and non-contract employees) who are unable to work due to illness or disability, whether or not such illness or disability is job-related, will continue, based on seniority, to receive most or all of their base salary and certain subsidies (but not bonuses) throughout the period of their absence, subject to certain time limitations. Employees who are unable to work due to job-related illnesses or disabilities will receive certain additional compensation from us. The compensation varies depending on the severity of the illness or disability. Structural changes being implemented by the Chinese and Shanghai governments and our own implementation of joint stock limited company accounting and financial principles may result in certain adjustments of the funding, management and payment methods for these types of worker's compensation arrangements over time.

E. Share Ownership.

The following table shows the ownership interests of our Directors, Supervisors and senior officers in our shares as of June 15, 2007. All shares indicated are A shares and are directly owned by the relevant persons. In each case, they represent less than 1% of the outstanding A shares. No change in shareholdings occurred. Except as disclosed below, none of the Directors, Supervisors or senior officers or their affiliates had any other beneficial interest in our issued share capital as of June 15, 2007.

Name	Position	Shares held at December 31, 2006
Rong Guangdao	Chairman and President	3,600
Du Chongjun	Vice Chairman	1,000
Han Zhihao	Director and Chief Financial Officer	0
Li Honggen	Director and Vice President	0
Dai Jinbao	Director	0
Shi Wei	Director and Vice President	0

Lei Dianwu	External Director	0
Xiang Hanyin	External Director	0
Sun Chiping	Independent Director	0
Jiang Zhiquan	Independent Director	0
Zhou Yunnong	Independent Director	0
Chen Xinyuan	Independent Director	0
Gao Jinping	Chairman of Supervisory Committee	0
Zhang Chenghua	Supervisor	0
Wang Yanjun	Supervisor	0
Geng Limin	External Supervisor	0
Lü Xiangyang	External Supervisor	0
Liu Xiangdong	Independent Supervisor	0
Yin Yongli	Independent Supervisor	0
Zhang Jianping	Vice President	0
Tang Chengjian	Vice President	0
Zhang Jingming	Company Secretary	0

We have no employee share purchase plan, share option plan or other arrangement to involve employees in our share capital.

ITEM 7. MAJOR SHAREHOLDERS AND RELATED PARTY TRANSACTIONS.

A. Major Shareholders.

Sinopec Corp owns 55.56% of our share capital and is able to exercise all the rights of a controlling shareholder, including the election of directors and voting on amendments to our Articles of Association.

The table below sets forth information regarding ownership of our capital stock as of June 15, 2007 by (i) all persons who we know own more than five percent of our capital stock and (ii) our officers and directors as a group. We are not aware that any such shareholder had voting rights different from those of our other shareholders.

Title of Class	Identity of Person or Group	Number of Shares Held	Percent of Total Share Capital
Domestic Shares	China Petroleum & Chemical Corporation ⁽¹⁾	4,000,000,000	55.56%
H Shares	HKSCC nominees Ltd.	1,928,505,401	26.78%
A Shares	Directors and Officers	4,600	less than 1%

⁽¹⁾ This company is controlled by China Petrochemical Corporation which is itself controlled by the Chinese government.

As of June 15, 2007, a total of 2,330,000,000 H Shares were outstanding. As of June 15, 2007, a total of 2,246,600 ADSs, representing the equivalent of 224,660,000 H Shares, were outstanding and held by 111 holders of record. A total of 720,000,000 A Shares were outstanding on June 15, 2007.

To the best of our knowledge, except as disclosed above, we are not directly or indirectly controlled by another corporation, any foreign government, or any other natural or legal person, severally or jointly.

We are not aware of any arrangement that may at a subsequent date result in a change of control of our company.

B. Related Party Transactions.

Intercompany service agreements

Prior to its restructuring, JI provided machinery, maintenance, transportation, medical care, technical training and other services to us, and we provided public utility services, such as water, electricity and steam, to JI. Following the restructuring of JI in August 1997 and the transfer of some of its subsidiaries to Sinopec and rest of its subsidiaries to Shanghai Jinshan District, the services agreement between us and JI was terminated. In March 1998, we entered into a new services agreement with Sinopec to replace the terminated services agreement. The new services agreement contains the same terms and conditions as those contained in the previous services agreement and the services are to be provided either at market prices or prices set by governmental authorities. Those services are currently provided by Sinopec Group. See Item 4. Information on the Company – History.

Business-related dealings

We have entered into transactions with each of Sinopec Corp, Sinopec Group and its predecessor, Sinopec, JI and their respective affiliated entities, all of which are our affiliates, and will continue to enter into transactions with each of Sinopec Corp, Sinopec Group and their affiliated entities. Transactions with Sinopec Corp and its affiliated entities include the allocation of crude oil and certain raw materials, the exclusive sale of our acrylic fibers production, and the sale of certain of our products pursuant to the State Plan.

Upon approval and authorization by the 2004 Extraordinary General Meeting held on June 28, 2005, we entered into a Sales and Purchases Framework Agreement with Sinopec Corp and a Comprehensive Services Framework Agreement with Sinopec. Under the Sales and Purchases Framework Agreement, we purchase raw materials from and sell petroleum products and petrochemicals to Sinopec Corp and its associates. Under the Comprehensive Services Framework Agreement, we will accept transportation, design, construction and installation, insurance agency and financial services provided by Sinopec Corp and its associates. The directors, including each of the independent non-executive directors confirm that these continuing connected transactions were conducted in accordance with the terms of Sales and Purchases Framework Agreement and the Comprehensive Services Framework Agreement throughout 2005. At the 2005 Extraordinary General Meeting held on June 28, 2005 and the 2005 Second Extraordinary General Meeting held on December 30, 2005, our shareholders approved certain caps on the annual transaction values of certain on going connected transactions for the years ended December 31, 2005, December 31, 2006 and December 31, 2007 were also approved. The directors, including each of the independent non-executive directors confirm that such continuing a connected transaction values did not exceed the caps so approved.

On August 25, 2005, the petrochemical products agency sales contract with Sinopec Corp was considered and approved at the second meeting of the fifth session of the Board. Pursuant to the contract, we appoint Sinopec Corp as a non-exclusive sales agent for the sales of synthetic resins, synthetic fibers, synthetic fiber monomers and polymers, organic petrochemical products and by-products from ethylene cracking and aromatic plants and other substandard products related to the above five products.

The purchases by us of crude oil-related materials from and sales of petroleum products by us to Sinopec Corp and its associates were conducted in accordance with the State's relevant policy and applicable State tariffs or State guidance prices. As long as the

State does not lift its control over purchases of crude oil, sales of petroleum products and pricing thereof, such connected transactions will continue to occur. We sell petrochemicals to Sinopec Corp and its associates and Sinopec Corp and its associates act as agents for the sale of petrochemicals in order to reduce our inventories, expand their trading, distribution and sales networks and improve our bargaining power with our customers. We accept transportation, design, construction and installation, insurance agency and financial services from Sinopec and its associates in order to secure steady and reliable services at reasonable prices.

<u>Type of transactions</u>	<u>Related parties</u>	<u>Amount</u>	<u>Unit: RMB' 000 Percentage of total amount of the type of transaction (%)</u>
Income from sale of products and services	Sinopec Eastern China Sales Company	15,842,808	31.38
	Other subsidiaries	4,330,298	8.58
Purchases	Sinopec Transport and Storage Company	24,992,620	50.80
	China International United Petroleum & Chemical Company Limited	6,230,910	12.66
Installation fees	Sinopec and its subsidiaries	194,958	49.37
Transportation costs	Sinopec Transport and Storage Company	316,326	69.75
	Other	28,602	6.31

This includes: an amount of RMB20,173,106,000 for the connected transactions in respect of the sale of products or the provision of labor services to the controlling shareholder and its subsidiaries by the listed company during 2006.

Other related party transactions

We transferred to Sinopec Corp. a 81.97% equity interest owned by our wholly owned subsidiary Shanghai Petrochemical Investment Development Company Limited in Shanghai Jin Hua Industrial Company Limited for a consideration of RMB61,600,400. The relevant transfer agreement was entered into on February 8, 2006. The transaction generated a gain of RMB24,307,946 in 2006. The pricing principle was determined on the basis of a valuation report prepared by a qualified asset valuer independent of the Company and Sinopec Corp. and upon arm's length negotiations between the parties. On the asset disposal date, the book value of the assets was RMB37,292,454, while the appraised value of the assets was RMB53,600,422 as at March 31, 2005.

We entered into equity transfer agreements with Sinopec Finance Co., Ltd to transfer our respective equity interests in China Everbright Bank and Bank of Shanghai to Sinopec Finance Co., Ltd. The considerations for the China Everbright Bank transfer and Bank of Shanghai transfer were RMB66,993,800 and RMB14,729,600, respectively. The relevant transfer agreements were entered into on December 7, 2006. As at the asset appraisal date, the book value of the equity interests held by the respective parties in China Everbright Bank and Bank of Shanghai totaled RMB55,449,641. The increase in the fair value of those equity interests of RMB26,228,500 as a result of the above transaction was recognized in the reserve, net of deferred tax, in 2006. The transaction prices were determined by way of a bidding process on the China Beijing Equity Exchange. The transfer of equity interest in China Everbright Bank was completed in April 2007. The transfer of equity interest in Bank of Shanghai is expected to be completed in July 2007.

We signed an agreement on December 30, 2005 to transfer our 2% equity interest in Sinopec Finance to Sinopec Corp for a purchase price of RMB82,000,000. In accordance with the payment terms of the agreement, we were paid the consideration on February 28, 2006.

We paid an amount of RMB164,763,000 to Sinopec Corp and its subsidiary which consisted of equipment pre-payments and progress payments for the 380,000 tons per year glycol project and the long-cycle facility of the 3,300,000 tons per year diesel hydrogenization project. Both facilities were delivered in the first half of the year in 2006.

We transferred 12.67% of our equity interest in China Jin Shan United Trading Co., Ltd., to China Petrochemical International Co., Ltd., a wholly-owned subsidiary of our controlling shareholder, Sinopec Corp, on April 28, 2005 for a purchase price of RMB10,000,000. RMB3,140,116 in gain was generated from the transaction in 2005. The pricing principle was based on a value appraised by a qualified asset appraiser independent to us and China Petrochemical International Co., Ltd. The face value of such portion of assets amounted to RMB6,859,883.70 and its assessed value amounted to RMB9,999,300.00. The transaction represented an opportunity for China Petrochemical International Co., Ltd. to increase its sales of products by expanding its trading, distribution and marketing network.

We transferred our land use rights in land covering an area of 690,000 sq. meters located at Zhusimen, Nanao Village, Cezi Township, Dinghai District, Zhoushan Municipality, Zhejiang Province, to China Petrochemical Corporation Pipelines Transportation Co., a branch company of our controlling shareholder, Sinopec Corp, on September 29, 2005, at a consideration of RMB62,741,700. RMB36,815,994 in gain was generated from the transaction in 2005. The pricing principle was based on a value appraised by a qualified property appraiser that was independent to both us and China Petrochemical Corporation Pipelines Transportation Co. The face value of such portion of assets amounted to RMB21,795,807 and its assessed value amounted to RMB62,741,700. We were of the view that the disposal of the surplus land generated immediate working capital to us. The discrepancy between the face value and the assessed value was due to the increase in property valuation.

Equity joint venture

Late in 2001, we established Secco, a Sino-foreign equity joint venture, together with BP and Sinopec Corp. We own a 20% interest in Secco, while BP and Sinopec Corp own 50% and 30% interests in Secco, respectively. Secco was established to build and operate a 900,000 ton Rated Capacity ethylene petrochemical manufacturing facility to manufacture and market ethylene, polyethylene, styrene, polystyrene, propylene, acrylonitrile, polypropylene, butadiene, aromatics and by products; provide related after-sales services and technical advice with respect to such petrochemical products and by products; and engage in polymers application development. Secco completed construction in 2005. Secco's total registered capital is US\$901,440,964, of which we provided the Renminbi equivalent of US\$180,287,952.

HKSE connected transactions waivers

The HKSE has granted two waivers from HKSE requirements that would require us to seek advance shareholder approval for transactions with related parties.

Transactions under the State Plan – Transactions entered into pursuant to the State Plan are exempt, provided that we disclose them to shareholders in our next annual report filed in Hong Kong (“HK Annual Report”).

Transactions with Sinopec Corp – The HKSE has confirmed that transactions with Sinopec Corp or its associates which were previously carried out with Sinopec and its associates and were covered by the waivers, continue to be exempt following the reorganization of Sinopec on the basis that there is no change in our ultimate controlling shareholder, provided that we satisfy the following conditions (such transactions will include transactions with Sinopec Group since Sinopec Group is the controlling company of Sinopec Corp):

- we disclose details of the transactions to shareholders in our next HK Annual Report,
- our independent non-executive directors certify in our next HK Annual Report that the transactions have been entered into (1) in the ordinary course of business of the relevant companies, (2) on normal commercial terms or on terms that are fair and reasonable so far as our shareholders are concerned and (3) the transactions have been entered into either in accordance with the terms of the agreement governing them or, where there is no such agreement, on terms no less favorable than terms available to third parties, and
- our auditors review the transactions each year.

If, however, disclosure of any such transactions is necessary to enable investors to appraise our position or to avoid the establishment of a fraudulent market in our shares or if such transactions may have any material effect on the trading of our shares on the HKSE, we are required to disclose the relevant transaction to the HKSE as soon as practicable. The expression “ordinary course of business” will be determined in the context of the actual business of the relevant company and the expression “normal commercial terms” will be applied by reference to transactions of a similar nature and to be made by similar entities within China or, in the absence of available comparison, by reference to our history and pattern of dealings. Please also see Note 27 to our consolidated financial statements included in Item 18. Financial Statements.

Other related party transactions

He Fei, a non-executive Director prior to June 18, 2002, is a partner of Haiwen & Partners, our legal advisor on Chinese laws, which has received and will continue to receive legal fees in connection with their representation of us.

C. Interests of Experts and Counsel.

Not applicable.

ITEM 8. FINANCIAL INFORMATION.

A. Consolidated Statements and Other Financial Information.

Please see Item 18. Financial Statements for our audited consolidated financial statements filed as part of this annual report.

Please see Item 17. Financial Statements for the separate financial statements and notes for Shanghai Secco Petrochemical Co., Ltd., which are being filed pursuant to Rule 3-09 of Regulation S-X.

Export Sales

In 2006, export sales accounted for RMB234.3 million (US\$30.01 million) or 0.46% of our total net sales.

Litigation

Neither we nor any of our subsidiaries is a party to, nor is any of our or their property the subject of any legal or arbitration proceedings which may have significant effects on our financial position or profitability. We are not aware of any litigation or arbitration proceedings in which any of our directors, any member of our senior management or any of our affiliates is an adverse party or has a material adverse interest.

Dividend Policy

Our board of directors may propose dividend distributions subject to the approval of the shareholders. The Articles of Association also provide that, unless the shareholders otherwise resolve, our board of directors is authorized in advance to distribute interim dividends each year of up to 50% of our distributable profits. Shareholders receive dividends in proportion to their shareholdings.

The Articles of Association require that cash dividends and other distributions in respect of H shares be declared in Renminbi and paid by us in Hong Kong dollars while cash dividends and other distributions in respect of our H shares be paid in Renminbi. If we record no profit for the year, we may not distribute dividends in such year.

We expect to continue to pay dividends, although there can be no assurance as to the particular amounts that might be paid from year to year. Payment of future dividends will depend upon our revenue, financial condition, future earnings and other factors. See Item 5. Operating and Financial Review and Prospects and Item 3. Key Information – Selected Financial Data – Dividends.

B. Significant Changes.

No significant change has occurred since the date of the financial statements included in this Annual Report.

ITEM 9. THE OFFER AND LISTING.

A. Offer and Listing Details

Set forth below is certain market information relating to our H Shares, ADSs and A Shares for the periods indicated.

	<u>Price per H Share</u>		<u>Price per ADS</u>		<u>Price per A Share</u>	
	<u>(HK\$)</u>		<u>(US\$)</u>		<u>(RMB)</u>	
	<u>High</u>	<u>Low</u>	<u>High</u>	<u>Low</u>	<u>High</u>	<u>Low</u>
2001	1.35	0.52	17.15	7.00	5.52	3.50
2002	1.28	0.69	15.61	8.74	4.46	2.80
2003	3.45	1.70	46.26	14.35	6.02	3.07
2004	4.07	1.86	53.90	24.30	8.15	4.37
2005	3.58	2.25	45.20	29.55	5.07	3.11
2006	5.00	2.97	64.60	38.60	7.18	4.03
2005						
First Quarter	3.58	2.60	45.20	34.01	5.07	4.07
Second Quarter	3.22	2.50	41.60	32.80	4.75	3.42
Third Quarter	3.00	2.50	40.00	32.45	4.25	3.20
Fourth Quarter	3.03	2.25	38.43	29.55	4.19	3.11
2006						
First Quarter	5.00	2.97	64.60	38.60	6.20	4.03
Second Quarter	4.75	3.28	62.00	41.49	7.18	5.21
Third Quarter	4.23	3.40	53.20	44.20	6.76	5.48
Fourth Quarter	4.04	3.13	51.44	40.85	6.55	4.72
Most Recent Six Months						
January 2007	4.42	3.77	54.90	48.95	7.71	6.05
February 2007	4.22	3.75	53.00	47.50	8.55	6.18
March 2007	4.20	3.49	53.40	44.55	9.65	7.57
April 2007	4.93	3.99	62.84	51.50	12.72	8.70
May 2007	6.18	4.44	75.95	57.00	15.77	12.50
June 2007 (up to June 15, 2007)	5.42	5.02	68.47	64.63	14.74	11.92

B. Plan of Distribution

Not applicable.

C. Markets

The principal trading market for our H Shares is the HKSE. The ADSs, each representing 100 H Shares, have been issued by The Bank of New York as a depository under a Deposit Agreement with us and are listed on the NYSE under the symbol "SHI." We have also listed our A Shares on the Shanghai Securities Exchange. Prior to our initial public offering on July 26, 1993 and subsequent listings on the HKSE and NYSE, there was no market for our H Shares or the ADSs. Public trading in our A Shares commenced on November 8, 1993.

D. Selling Shareholders

Not applicable.

E. Dilution

Not applicable.

F. Expenses of the issue

Not applicable.

ITEM 10.ADDITIONAL INFORMATION.

A. Share Capital

Not applicable.

B. Memorandum and Articles of Association.

The following is a summary based upon provisions of our Articles of Association as currently in effect, the Company Law of the People's Republic of China (1993) and other selected laws and regulations applicable to us. You should refer to the text of the Articles of Association and to the texts of applicable laws and regulations for further information.

We are a joint stock limited company established in accordance with the Company Law and certain other laws and regulations of the PRC. We are registered with the Shanghai Administration of Industry and Commerce with business license number 3100001002263. Our Articles of Association provide, at article 12, that our purpose is:

- to build and operate a diversified industrial company which will be one of the world's leading petrochemical companies;
- to promote the development of the petrochemical industry in China through the production of a broad variety of outstanding products; and
- to practice advanced, scientific management and apply flexible business principles, and to develop overseas markets for our products so that we and our shareholders receive reasonable economic benefits.

Our scope of business is limited to matters approved by Chinese authorities. Article 13 provides that our primary business scope includes:

- refining crude oil, a wide range of petroleum products, petrochemical products, basic organic chemicals, synthetic fibers and monomers, plastic products, polyester fibers and yarns, raw materials for knitting and textile products and finished products; and
- production and operation of industrial fuels, production and operation of other by-products and refining and processing of platinum metals.

Our secondary scope of operation includes: electricity generation, supply of heat, supply of liquefied petroleum gas, water treatment, railways, ocean and inland water transport, warehousing, real estate, technical consultation, import and export, research and all other activities incidental and consistent with our primary and secondary operation and business scope. We may adjust these subject to approval by governmental authorities.

The following discussion primarily concerns our shares and the rights of our shareholders. Holders of our ADSs will not be treated as our shareholders and will be required to surrender their ADSs for cancellation and withdrawal from the depository facility in which the H shares are held in order to exercise shareholder rights in respect of H shares.

Domestic shares and overseas-listed foreign invested H shares are both ordinary shares in our share capital. Domestic shares are shares we issue to domestic Chinese investors for subscription in Renminbi, while H shares are shares we issue for subscription in other currencies to investors from Hong Kong, Macau, Taiwan and outside of China.

Sources of Shareholders' Rights

China's legal system is based on written statutes and is a system in which decided legal cases have little precedent value. China's legal system is similar to civil law systems in this regard. In 1979, China began the process of developing its legal system by undertaking to promulgate a comprehensive system of laws. In December 1993, the Standing Committee of the 8th National People's Congress adopted the Chinese Company Law. Although the Chinese Company Law is expected to serve as the core of a body of regulatory measures, which will impose a uniform standard of corporate behavior on companies and their directors and shareholders, only a limited portion of this body of regulatory measures has so far been promulgated.

Currently, the primary sources of shareholder rights are the Articles of Association, the Chinese Company Law and the HKSE listing rules, which, among other things, impose standards of conduct, fairness and disclosure on us, our directors and our controlling shareholder. To facilitate the offering and listing of shares of Chinese companies overseas, and to regulate the behavior of companies whose shares are listed overseas, the State Council Securities Committee and the State Commission for Restructuring the Economic System issued the Mandatory Provisions for articles of association of Companies Listing Overseas on August 27, 1994. These provisions have been incorporated into our Articles of Association and any amendment to those provisions will only become effective after approval by the companies approval department of local government authorized by the State Economic and Trade Commission and the China Securities Regulatory Commission.

In addition, upon the listing of and for so long as the H shares are listed on the HKSE, we will be subject to those relevant ordinance, rules and regulations applicable to companies listed on the HKSE, the Securities (Disclosure of Interests) Ordinance and the Hong Kong Codes on Takeovers and Mergers and Share Repurchases.

Unless otherwise specified, all rights, obligations and protections discussed below derive from our Articles of Association and/or the Chinese Company Law.

Enforceability of Shareholders' Rights

There has not been any public disclosure in relation to the enforcement by holders of H shares of their rights under the charter documents of joint stock limited companies or the Chinese Company Law or in the application or interpretation of the Chinese or Hong Kong regulatory provisions applicable to Chinese joint stock limited companies.

In most states of the United States, shareholders may sue a corporation "derivatively". A derivative suit involves the

commencement by a shareholder of a corporate cause of action against persons who have allegedly wronged the corporation, where the corporation itself has failed to enforce the claims directly. This would include suits against corporate officers, directors, or controlling shareholders. This type of action is brought based upon a primary right of the corporation, but is asserted by a shareholder on behalf of the corporation. Because the right to sue derivatively is not available under Chinese law, our shareholders may have to rely on other means to enforce the rights of shareholders, such as through administrative proceedings.

Our Articles of Association provide that all differences or claims

- between a holder of H shares and us;
- between a holder of H shares and any of our directors, supervisors, manager or other senior officers; or
- between a holder of H shares and a holder of domestic shares,

involving any right or obligation provided in the Articles of Association, the Chinese Company Law or any other relevant law or administrative regulation which concerns our affairs must, with certain exceptions, be referred to arbitration at either the China International Economic and Trade Arbitration Commission in China or the Hong Kong International Arbitration Center. Our Articles of Association also provide that the arbitration will be final and conclusive. On June 21, 1999, an arrangement was made between Hong Kong and China for the summary mutual enforcement of each other's arbitration awards in a manner consistent with the United Nations Convention on the Recognition and Enforcement of Foreign Arbitral Awards and practices that occurred before the handover of Hong Kong to China. This arrangement was approved by the Supreme Court of China and the Hong Kong Legislative Council, and became effective on February 1, 2000.

All of our directors and officers reside outside the United States (principally in China) and substantially all of our assets and of those persons are located outside the United States. Therefore, you may not be able to effect service of process within the United States against any of those persons. In addition, China does not have treaties providing for the reciprocal recognition and enforcement of judgments of courts within the United States or most other countries that are members of the Organization for Economic Cooperation and Development. This means that administrative actions brought by regulatory authorities such as the Securities and Exchange Commission, and other actions which result in foreign court judgments could only be enforced in China if the judgments or rulings do not violate the basic principles of the law of China or the sovereignty, security and social public interest of the society of China, as determined by a People's Court of China which has jurisdiction for recognition and enforcement of judgments. We have been advised by our Chinese counsel, Haiwen & Partners, that there is doubt as to the enforceability in China of any actions to enforce judgments of United States courts arising out of or based on the ownership of our H shares or ADSs, including judgments arising out of or based on the civil liability provisions of United States federal or state securities laws.

Restrictions on Transferability and the Share Register

All fully paid up H shares will be freely transferable in accordance with the Articles of Association unless otherwise prescribed by law and/or administrative regulations. Under current laws and regulations, H shares may be traded only among investors who are not Chinese persons, and may not be sold to Chinese investors. Consequences under Chinese law of a purported transfer of H shares to Chinese investors are unclear.

As provided in our Articles of Association, we may refuse to register a transfer of H shares without providing any reason unless:

- all relevant transfer fees and stamp duties are paid;
- the instrument of transfer is accompanied by the share certificates to which it relates and any other evidence reasonably required by our board to prove the transferor's right to make the transfer;
- there are no more than four joint holders as transferees; and
- the H shares are free from any lien of ours.

Additionally, no transfers of shares may be registered within the 30 days prior to a shareholders' general meeting or within five days before we decide on the distribution of dividends.

We are required to keep a register of our shareholders which shall be comprised of various parts, including one part which is to be maintained in Hong Kong in relation to H shares listed on the HKSE. Shareholders have the right to inspect the share register. For a reasonable fee, shareholders may copy any part of the share register, obtain background information regarding our directors, supervisors, manager and other senior officers, minutes of shareholder general meetings and reports regarding our share capital and any share repurchases in the prior year.

Dividends

Our Articles of Association require the Company to distribute dividends annually in the second quarter of the year following that in which the Company made the profits from which the dividend is paid. The Articles of Association allow for distribution of dividends in the form of cash or shares. A distribution of shares, however, must be approved by special resolution of the shareholders.

Dividends may only be distributed, however, after allowance has been made for:

- recovery of losses, if any;
- allocations to the statutory common reserve fund;
- payment of dividends on any preference shares we issue in the future; and
- allocations to a discretionary common reserve fund.

The Articles of Association require us to appoint on behalf of the holders of H shares a receiving agent which is registered as a trust corporation under the Trustee Ordinance of Hong Kong to receive dividends we declare in respect of the H shares on behalf of the H shareholders. The Articles of Association require that cash dividends and other distributions in respect of H shares be declared in Renminbi and paid by us in Hong Kong dollars while cash dividends and other distributions of the domestic shares shall be paid in Renminbi.

If we record no profit for the year, we may not normally distribute dividends for the year.

Dividend payments may be subject to Chinese withholding tax. See Item 10. Additional Information – Taxation.

Voting Rights and Shareholders' Meetings

Our board of directors must convene a shareholders' annual general meeting once every year within six months from the end of the preceding financial year. Our board must convene an extraordinary general meeting within two months of the occurrence of any one of the following events:

- where the number of directors is less than 10 or two-thirds of the number specified in our Articles of Association;
- if the number of directors is less than five, the number stipulated in the Chinese Company Law;
- where our unrecovered losses reach one-third of the total amount of our share capital;
- where shareholder(s) holding 10% or more of our issued and outstanding voting shares request(s) in writing; or
- whenever our board deems necessary or our Supervisory Committee so requests.

Meetings of a special class of shareholders must be called in specified situations when the rights of the holders of that class of shares may be varied or abrogated, as discussed below. Resolutions proposed by our Supervisory Committee or shareholder(s) holding 5% or more of the total number of voting shares shall be included in the agenda for the relevant annual general meeting if they are matters which fall within the scope of the functions and powers of shareholders in general meeting.

All shareholders' meetings must be convened by our board by notice given to shareholders by personal service, mail or announcement in the newspaper not less than 45 days before the meeting. Based on the written replies we receive 20 days before a shareholders' meeting, we will calculate the number of voting shares represented by shareholders who have indicated that they intend to attend the meeting. We can convene the shareholders' general meeting if the number of voting shares represented by those shareholders is more than one-half of our total voting shares, regardless of the number of shareholders who actually attend the meeting. Otherwise, we shall, within five days, inform the shareholders again of the motions to be considered and the date and venue of the meeting by way of public announcement. After the announcement is made, the shareholders' meeting may be convened. Our accidental omission to give notice of a meeting to, or the non-receipt of notice of a meeting by, a shareholder will not invalidate the proceedings at that shareholders' meeting. However, an extraordinary shareholders meeting cannot conduct any business not contained in the notice of meeting.

Shareholders at meetings have the power, among other things, to decide on our operational policies and investment plans, to approve or reject our proposed annual budget, approve or reject our profit distribution plans, an increase or decrease in share capital, the issuance of debentures, our merger or liquidation and any amendment to our Articles of Association. Shareholders also have the right to review any proposals by a shareholder owning 5% or more of our shares. In general, holders of H shares and domestic shares vote together as a single class at all meetings and on all matters. However, the rights of a class of shareholders may not be varied or abrogated, unless approved by both a special resolution of all shareholders at a general shareholders' meeting and by a special resolution of shareholders of that class of shares at a separate meeting. Our Articles of Association specify, without limitation, that the following amendments would be deemed to be a variation or abrogation of the rights of a class of shareholders:

- increasing or decreasing the number of shares of a class or of a class having voting or distribution rights or privileges equal or superior to that class;

-
- removing or reducing rights to receive dividends in a particular currency;
 - creating shares with voting or distribution rights superior to shares of that class;
 - restricting or adding restrictions to the transfer of ownership of shares of that class;
 - allotting and issuing rights to subscribe for, or to convert into, shares of that class or another class;
 - increasing the rights or privileges of any other class; or
 - modifying the provision of our Articles of Association that specifies which amendments would be deemed a variation or abrogation of the rights of a class of shareholder.

For votes on any of these matters, or any other matter that would vary or abrogate the rights of the domestic shares or H shares, the holders of domestic shares and H shares are deemed to be separate classes and vote separately. However, “Interested Shareholders” are not entitled to vote at class meetings. The meaning of “Interested Shareholder” depends on the proposal to be voted on at the class meeting:

- If the proposal is for us to repurchase our shares either from all shareholders proportionately or by purchasing share on a stock exchange, an “Interested Shareholder” is our controlling shareholder;
- If the proposal is for us to repurchase our shares from a shareholder by a private contract, an “Interested Shareholder” is the shareholder whose shares would be repurchased;
- If the proposal is for our restructuring, an “Interested Shareholder” is any shareholder that has an interest in the restructuring different from the other shareholders of the class or who bears a burden under the proposed restructuring that is less than proportionate to his shareholdings of the class.

Our Articles of Association specifically provide that an issue of up to 20% of domestic and H shares would not be a variation or abrogation of the rights of domestic shareholders or H shareholders, therefore, separate approval of the domestic shareholders or H Shareholders would not be required.

Each share is entitled to one vote on all matters submitted to a vote of our shareholders at all shareholders’ meetings, except for meetings of a special class of shareholders where only holders of shares of the affected class are entitled to vote on the basis of one vote per share of the affected class.

Shareholders are entitled to attend and vote at meetings either in person or by proxy. Proxy authorization forms must be in writing and deposited at our company’s principal offices, or at such other place specified in the notice of shareholders meeting not less than 24 hours before the time that the such meeting will be held or the time appointed for passing upon the relevant resolutions. If a proxy authorization form is signed by a third party on behalf of the relevant shareholder, then such proxy authorization form must

be accompanied by the signature authorization letter or other such document authorizing such third party to sign on behalf of the shareholder.

Except for those actions discussed below, which require supermajority votes, or special resolutions, resolutions of the shareholders are passed by a simple majority of the voting shares held by shareholders who are present in person or by proxy. Special resolutions must be passed by more than two-thirds of the voting rights represented by shareholders who are present in person or by proxy.

The following decisions must be adopted by special resolution:

- an increase or reduction of our share capital or the issue of shares of any class, warrants and other similar securities;
- the issue of our debentures;
- our division, merger, dissolution and liquidation;
- amendments to our Articles of Association;
- significant acquisition or disposal of material assets or provision of guarantees conducted within the period of one year with a value exceeding 30% of our latest audited total assets;
- share incentive schemes; and
- any other matters considered by the shareholders in a general meeting and which they have resolved by way of an ordinary resolution to be material and should be adopted by special resolution.

All other actions taken by the shareholders, including the appointment and removal of our directors and independent auditors and the declaration of normal dividend payments, will be decided by an ordinary resolution of the shareholders.

Our listing agreement with the HKSE provides that we may not permit amendments to certain sections of our Articles of Association that are subject to the Mandatory Provisions. These sections include provisions relating to (i) varying the rights of existing classes of shares, (ii) voting rights, (iii) our ability to purchase our own shares, (iv) rights of minority shareholders and (v) procedures on liquidation. In addition, certain amendments to the Articles of Association require the approval and assent of Chinese authorities.

Board of Directors

Our Articles of Association authorize up to 19 directors. Directors are elected by shareholders at a general meeting for a three year term from among candidates nominated by the board of directors or by shareholders holding 5% or more of our shares. Because our directors do not serve staggered terms, the entire board of directors will stand for election, and could be replaced, every three years. Our directors are not required to hold any shares in us, and there is no age limit requirement for the retirement or non-retirement of our directors.

In addition to obligations imposed by laws, administrative regulations or the listing rules of the stock exchanges on which our shares are listed, the Articles of Association place on each of our directors, supervisors, manager and any other senior officers a duty to each shareholder, in the exercise of our functions and powers entrusted to them:

- not to cause us to exceed the scope of business stipulated in our business license;

-
- to act honestly in what he considers our best interests;
 - not to expropriate our assets in any way, including (without limitation) usurpation of opportunities which may benefit us; and
 - not to expropriate the individual rights of shareholders, including (without limitation) rights to distributions and voting rights, except according to a restructuring which has been submitted to the shareholders for their approval in accordance with the Articles of Association.

Our Articles of Association further place on each of our directors, supervisors, manager and other senior officers:

- a duty, in the exercise of their powers and discharge of their duties, to exercise the care, diligence and skill that a reasonably prudent person would exercise in comparable circumstances;
- a fiduciary obligation, in the discharge of his duties, not to place himself or herself in a position where his or her interests may conflict with his or her duty to us; and
- a duty not to cause a person or an organization related or connected to him or her in specified relationships to do what they are prohibited from doing.

We pay all expenses that our directors incur for their services as directors. Directors also receive compensation for their services under service contracts that are negotiated by the supervisory committee and approved by the shareholders.

Subject to the stipulations of relevant laws and regulations, the shareholders in a general meeting may by ordinary resolution remove any director before the expiration of his term of office. Except for the restrictions placed on controlling shareholders, discussed below, our shareholders in general meeting have the power to relieve a director, supervisor, manager or senior officer from liability for specific breaches of duty.

Cumulative voting is required for election of our directors as long as more than 30% of our outstanding shares are held by a single shareholder. Cumulative voting allows shareholders to cast a number of votes for a candidate equal to the number of shares held multiplied by the number of directors being elected at the shareholders' meeting. If a shareholder attempts to cast more votes than he is entitled to under this system, all of the shareholder's votes will be invalid and will be deemed an abstention.

More than one third of our directors of board must be independent from our shareholders and not hold any office with us (each, "Independent Director"). At least one Independent Director must be an accounting professional and all Independent Directors must possess a basic knowledge of the operations of a listed company and be familiar with relevant laws and rules and have at least five years working experience in law, economics or other area required for the fulfillment of responsibilities as an Independent Director. Independent Directors may not serve for terms exceeding six years. In addition, there are specific persons who are disqualified from acting as Independent Director. These include:

- immediate family members of persons who work for us or our associated entities;

-
- persons or their immediate family who hold one percent or more of our shares or are among our ten largest shareholders;
 - any persons that satisfied the foregoing conditions within the past one year;
 - persons providing financial, legal, consultation or other services to us or our associated entities;
 - persons who already serve as Independent Director for five other listed companies; and
 - anyone designated by the China Securities Regulatory Commission.

If the resignation of an Independent Director would cause our Board of Directors to have less than one third Independent Directors, the resignation will only become effective after a new Independent Director has been appointed.

Our Board will be required to meet at least four times each year. Directors who miss two consecutive Board meetings without appointing an alternate director to attend on their behalf will be proposed for removal at the next shareholders' meeting, provided that Independent Directors may miss three consecutive meetings before being proposed for removal. Otherwise, Independent Directors cannot be removed without cause.

Directors may not vote on any matter in which he has a material interest, nor will he be counted for purposes of forming a quorum on such a matter.

Board resolutions are passed by a simple majority of the Directors except for the following matters which require the consent of more than two thirds of the Directors:

- proposals for our financial policies;
- the increase or reduction of our registered capital;
- the issue of securities of any kind and their listing;
- any repurchase of our shares;
- significant acquisitions or disposals;
- our merger, division or dissolution; and
- any amendment to our Articles of Association.

Our Board of Directors or Supervisory Committee may nominate candidates for our Board of Directors and Supervisory Committee. In addition, shareholders holding one percent or more of our shares have the right to nominate candidates for Independent Director or Independent Supervisor and shareholders holding five percent or more of our shares have the right to nominate other candidates for Director or Supervisor. For Director candidates, the nominator and candidate will be responsible for providing truthful

and complete information about the candidate for disclosure. Candidates for Independent Director must publicly declare that there does not exist any relationship between himself and us that may influence his independent, objective judgment. The China Securities Regulatory Commission may veto any candidate for Independent Director.

Our Independent Directors must approve any connected transactions. Connected transactions are those defined by the HKSE and by Chinese rules and regulations, but would generally include transactions with any of the following:

- any company that, directly or indirectly, controls us or is under common control with us;
- any shareholders owning 5% or more of our shares;
- our directors, supervisors and other senior management;
- any of our key technical personnel or key technology suppliers; and
- any close relative or associate of any of the above.

Our independent directors can also propose to the Board of Directors the appointment or removal of our auditors, the convening of a Board meeting, independently appoint external auditors, solicit votes from shareholders and report circumstances directly to shareholders, Chinese securities regulatory authorities or other government departments. Two or more may request that the Board convene an extraordinary meeting of shareholders.

Our Independent Directors will have to express their opinion on specified matters to the Board or to the shareholders at a shareholders' meeting, either by a single unanimous statement or individually. These matters are:

- the nomination, removal and remuneration of directors or senior management;
- any major loans or financial transactions with our shareholders or related enterprises and whether we have taken adequate steps to ensure repayment;
- matters that the Independent Director believes may harm the rights and interests of minority shareholders; and
- any other matter that they are required to opine on by applicable law or rules.

These opinions must be expressed as either, agree, qualified agreement, opposition or unable to form an opinion. All but agreement must also be accompanied by a supporting explanation. If public disclosure of the matter is required, we must also disclose the opinions of our Independent Directors.

Any Independent Director may engage independent institutions to provide independent opinions as the basis of their decision. We must arrange the engagement and bear any costs.

Supervisory Committee

The Supervisory Committee is responsible for supervising our directors and senior officers and preventing them from abusing

their positions and powers or infringing upon the rights and interests of our company or those of our shareholders and employees. The Supervisory Committee has no power over the decisions or actions of our directors or officers to correct any acts that are harmful to our interests. The Supervisory Committee is currently composed of seven members appointed for a three year term. It has the right to:

- attend the meetings of our board of directors;
- inspect our financial affairs;
- supervise and evaluate the conduct of our directors, general manager and other senior officers in order to determine whether they violate any laws, regulations or the Articles of Association in performing their duties;
- require our directors, general manager or other senior officers to correct any act harmful to our interests and those of our shareholders and employees;
- verify financial reports, accounting reports, business reports, profit distribution plans and other financial information proposed to be tabled at the shareholders' general meeting;
- require the board of directors to convene an extraordinary general meeting of shareholders;
- represent us in negotiations with directors or in initiating legal proceedings against a director on our company's behalf;
- conduct investigation into any identified irregularities in our operations, and where necessary, to engage accountants, legal advisers or other professionals to assist in the investigation; and
- any other matters authorized by the Articles of Association.

Our Supervisory Committee must include two employee representatives appointed by our employees. The remaining members are appointed by the shareholders in a general meeting, provided that our directors, general manager and senior officers are not eligible to serve as supervisors. The Supervisory Committee must meet at least once a year. Decisions of the Supervisory Committee must be made by a one-half vote. We will pay all reasonable expenses incurred by the Supervisory Committee in appointing professional advisors, such as lawyers, accountants or auditors.

Liquidation Rights

In the event of our liquidation, payment of debts out of our remaining assets will be made in the order of priority prescribed by applicable laws and regulations. After payment of debts, we will distribute the remaining property to shareholders according to the class and proportion of their shareholdings. For this purpose, the H shares will rank equally with the domestic shares.

Obligation of Shareholders

Shareholders are not obligated to make any further contributions to our share capital other than as agreed by the subscriber of the relevant shares on subscription. This provision means that holders of ADSs will also not be obligated to make further contributions to our share capital.

Duration

We are organized as a joint stock limited company of indefinite duration.

Increase in Share Capital

The Articles of Association require that approval by a resolution of the shareholders be obtained prior to issuing new shares. New issues of shares must also be approved by the relevant Chinese authorities.

Reduction of Share Capital and Purchase by Us of Our Shares

We may reduce our registered share capital only upon obtaining the approval of the shareholders and, when applicable, relevant Chinese authorities. Repurchases may be made either by way of a general offer to all shareholders in proportion to their shareholdings, by purchasing our shares on a stock exchange or by an off-market contract with individual shareholders.

Restrictions on Large or Controlling Shareholders

Our Articles of Association provide that, in addition to any obligation imposed by laws and administrative regulations or required by the listing rules of the stock exchanges on which our shares are listed, a controlling shareholder cannot exercise voting rights in a manner prejudicial to the interests of the shareholders generally or of some part of the shareholders:

- to relieve a director or supervisor from his or her duty to act honestly in our best interest;
- to approve the expropriation by a director or supervisor (for his or her own benefit or for the benefit of another person) of our assets in any way, including, without limitation, opportunities which may benefit us; or
- to approve the expropriation by a director or supervisor (for his or her own benefit or for the benefit of another person) of the individual rights of other shareholders, including, without limitation, rights to distributions and voting rights (but not according to a restructuring of our company which has been submitted for approval by the shareholders in a general meeting in accordance with our Articles of Association).

A controlling shareholder, however, will not be precluded by our Articles of Association or any laws and administrative regulations or the listing rules of the stock exchanges on which our shares are listed from voting on these matters.

A controlling shareholder is defined by our Articles of Association as any person who, acting alone or together with others:

- has the power to elect more than one-half of the board of directors;
- has the power to exercise, or to control the exercise of, 30% or more of our voting rights;
- holds 30% or more of our issued and outstanding shares; or
- has *de facto* control of us in any other way.

Minutes, Accounts and Annual Report

Our shareholders may inspect copies of the minutes of the shareholders' general meetings during our business hours free of charge. Shareholders are also entitled to receive copies of these minutes within seven days of receipt of the reasonable charges we may require.

Our fiscal year is the calendar year ending December 31. Each fiscal year, we must mail our financial report to shareholders not less than 21 days before the date of the shareholders' annual general meeting. These and any interim financial statements must be prepared in accordance with Chinese accounting standards and, for so long as H shares are listed on the HKSE, must also be prepared in accordance with or reconciled to either Hong Kong accounting standards or international accounting standards. The financial statements must be approved by an ordinary resolution of the shareholders at the annual general meeting.

Independent auditors are appointed each year by the shareholders at the annual meeting.

C. Material Contracts.

We have not entered into any material contracts other than in the ordinary course of business and other than those described in Item 4. "Information on the Company" or elsewhere in this annual report on Form 20-F.

D. Exchange Controls.

Our Articles of Association require that cash dividends on our H Shares be declared in Renminbi and paid in HK dollars. The Articles of Association further stipulate that such dividends must be converted to HK dollars at a rate equal to the average of the closing exchange rates for HK dollars as announced by the Chinese Foreign Exchange Trading Center for the calendar week preceding the date on which the dividends are declared.

The Renminbi currently is not a freely convertible currency. The Chinese government imposes control over its foreign currency reserves in part through direct regulation of the conversion of Renminbi into foreign exchange, through control of foreign debts borrowed by domestic enterprises and through restrictions on foreign imports. The State Administration of Foreign Exchange ("SAFE"), under supervision of the People's Bank of China ("PBOC"), is responsible for matters relating to foreign exchange administration.

Foreign exchange transactions involving Renminbi must take place through financial institutions authorized to undertake foreign exchange conversion transactions, such as Chinese state-owned or foreign banks. Access to foreign exchange and the ability to remit foreign exchange abroad are regulated by Chinese government policies administered by the SAFE.

On July 21, 2005, the Chinese government changed its policy of pegging the Renminbi to the U.S. dollar. Under the new policy, the Renminbi is permitted to fluctuate within a narrow and managed band against a basket of certain foreign currencies. Since the adoption of this new policy, the value of the Renminbi has fluctuated daily within a narrow band, but overall has appreciated against the US dollar. Nevertheless, the PRC government continues to receive significant international pressure to further liberalize its currency policy which could result in a further and more significant appreciation in the value of the Renminbi against the US dollar.

All international commercial loans borrowed by domestic enterprises have to be registered with the SAFE before the loans become effective. Domestic enterprises and institutions are permitted to buy foreign exchange from State-designated banks at designated times upon presentation of appropriate documentation establishing the existence of import contracts or payment notes of overseas financial institutions. Such enterprises and institutions also are permitted to purchase foreign exchange for the import of certain products subject to quotas, import permits and registration controls. Domestic enterprises are permitted to apply to purchase foreign exchange for the payment of dividends that have been authorized as payable in foreign currency. Conversion and payment are to be effected on the basis of a written resolution on profit distribution passed by the enterprise's board of directors and evidence that the enterprise has paid all required Chinese taxes.

While the impact of the foregoing developments is not entirely clear, it appears that the trend in the Chinese government's foreign exchange policy is toward easier convertibility of the Renminbi.

The holders of the ADSs will receive the HK dollar dividend payments in US dollars at conversion rates related to market rates and subject to fees as set forth in our Deposit Agreement with The Bank of New York, as Depositary. The HK dollar is currently linked to and trades within a narrow band against the US dollar at a rate that does not deviate significantly from HK\$7.80 = US\$1.00. The Hong Kong government has stated its intention to maintain such link, although there can be no guarantee that such link will be maintained.

E. Taxation

PRC Taxation

The following is a summary of those taxes, including withholding provisions, to which United States security holders are subject under existing Chinese laws and regulations. The summary is subject to changes in Chinese law, including changes that could have retroactive effect. The summary does not take into account or discuss the tax laws of any country other than China, nor does it take into account the individual circumstances of a security holder. This summary does not purport to be a complete technical analysis or an examination of all potential tax effects under such laws and regulations.

Tax on Dividends

For an Individual Investor

According to the Individual Income Tax Law of the People's Republic of China, as amended on October 27, 2005 (the "Individual Income Tax Law") dividends paid by Chinese companies to foreign individuals are ordinarily subject to Chinese withholding tax at a flat rate of 20%.

However, pursuant to the Notice Concerning the Taxation of Gains on Transfer and Dividends from Shares (Equities) Received by Foreign Investment Enterprises, Foreign Enterprises and Foreign Individuals (the "Tax Notice"), issued by the State Tax Bureau (now the State Administration of Taxation or "SAT") on July 21, 1993, dividends paid by Chinese companies to foreign individuals, with respect to their shares listed on an overseas stock exchange ("Overseas Shares"), such as H Shares (including H Shares represented by ADSs), or on domestically-listed foreign invested shares ("B Shares") are temporarily exempt from Chinese withholding tax. The Tax Notice remains in force and the relevant tax authority has thus far not collected withholding tax on dividends paid by Chinese companies, with respect to their Overseas Shares and B Shares, to foreign individuals.

In the event that the Tax Notice is withdrawn, a 20% withholding tax may be imposed in accordance with the Individual Income Tax Law, subject to reduction by an applicable income tax treaty.

For a Corporation

According to the Income Tax Law of the People's Republic of China for Enterprises with Foreign Investment and Foreign Enterprises of April 9, 1991, as amended (the "Foreign Corporate Income Tax Law"), dividends paid by Chinese companies to foreign corporations are ordinarily subject to Chinese withholding tax at a flat rate of 20%.

However, pursuant to the Tax Notice, dividends paid by Chinese companies, with respect to their Overseas Shares and B Shares, to foreign corporations are temporarily exempt from Chinese withholding tax. Again, the Tax Notice remains in force and the relevant tax authority has thus far not collected withholding tax on dividends paid by Chinese companies, on their Overseas Shares and B Shares, to foreign corporations.

In the event that the Tax Notice is withdrawn, a 20% withholding tax may be imposed in accordance with the Foreign Corporate Income Tax Law, subject to reduction by an applicable income tax treaty.

The New Enterprise Income Tax Law, promulgated on March 16, 2007, will replace the Foreign Corporate Income Tax Law when it takes effect on January 1, 2008. The withholding tax rate for dividends remains at 20% under the New Enterprise Income Tax Law. Assuming that the Tax Notice continues to remain in force, the exemptions noted above will continue to apply once the New Enterprise Income Tax Law takes effect.

Capital Gains Tax

According to the Individual Income Tax Law, the Foreign Corporate Income Tax Law, their respective implementing regulations, and the Notice on Questions Relating to Reduced Income Tax on Foreign Enterprise Income in China from Interest, issued by the State Council on November 18, 2000 (the "Rate Reduction Notice"), capital gains recognized by foreign individuals and foreign corporations, with respect to their sale of equity shares of Chinese companies, are ordinarily subject to Chinese tax, purportedly in the form of withholding tax, at a flat rate of 20% and 10% respectively.

However, pursuant to the Tax Notice, capital gains recognized by foreign individuals and foreign corporations, with respect to their sale of Overseas Shares and B Shares are temporarily exempt from Chinese tax. As discussed above, the Tax Notice remains in force and the relevant tax authority has thus far not sought to collect Chinese tax on capital gains recognized by foreign individuals and foreign corporations with respect to their sale of Overseas Shares and B Shares.

In the event that the Tax Notice is withdrawn, Chinese tax, at a rate of 20% for individuals or 10% for corporations may be imposed in accordance with the Individual Income Tax Law, the Corporate Income Tax Law, their respective implementing regulations and the Rate Reduction Notice, subject to reduction by an applicable income tax treaty.

Assuming that the Tax Notice continues to remain in force, the exemptions noted above will continue to apply once the New Enterprise Income Tax Law takes effect.

Tax Treaties

China has an income tax treaty with the United States that currently limits the rate of Chinese withholding tax to 10% for dividends paid to individuals and corporations that qualify for treaty benefits. However, this treaty does not offer reduced tax rates for capital gains. Since the Tax Notice remains in force to temporarily exempt dividends and capital gains from the Chinese taxes described above, it may not be necessary for foreign individuals and corporations to rely on this treaty at this time.

Stamp Tax

While no express exemption exists for the imposition of Chinese stamp tax on transfers of Overseas Shares pursuant to the Provisional Regulations of the People's Republic of China Concerning Stamp Tax effective on July 1, 1989, we are not aware of any circumstance under which Chinese stamp tax has actually been imposed on the transfer of Overseas Shares.

Estate or Gift Tax

China does not currently impose any estate or gift tax.

U.S. Taxation

The following is a summary of the material U.S. federal income tax consequences of the ownership and disposition of H Shares or ADSs. The following discussion is not exhaustive of all possible tax considerations. This summary is based upon the Internal Revenue Code of 1986, as amended (the "Code"), regulations promulgated under the Code by the U.S. Treasury Department (including proposed and temporary regulations), rulings, current administrative interpretations and official pronouncements of the Internal Revenue Service (the "IRS"), and judicial decisions, all as currently in effect and all of which are subject to differing interpretations or to change, possibly with retroactive effect. Such change could materially and adversely affect the tax consequences described below. No assurance can be given that the IRS will not assert, or that a court will not sustain, a position contrary to any of the tax consequences described below.

This discussion does not address state, local, or foreign tax consequences of the ownership and disposition of H Shares or ADSs. (See "PRC Taxation" above).

This summary is for general information only and does not address all aspects of the U.S. federal income taxation that may be important to a particular holder in light of its investment or tax circumstances or to holders subject to special tax rules, such as: banks; financial institutions; insurance companies; dealers in stocks, securities, or currencies; traders in securities that elect to use a mark-to-market method of accounting for their securities holdings; tax-exempt organizations; real estate investment trusts; regulated investment companies; qualified retirement plans, individual retirement accounts, and other tax-deferred accounts; expatriates of the United States; persons subject to the alternative minimum tax; persons holding H Shares or ADSs as part of a straddle, hedge, conversion transaction, or other integrated transaction; persons who acquired H Shares or ADSs pursuant to the exercise of any employee stock option or otherwise as compensation for services; persons actually or constructively holding 10% or more of our voting stock; and U.S. Holders (as defined below) whose functional currency is other than the U.S. dollar.

This discussion is not a comprehensive description of all of the U.S. federal tax consequences that may be relevant with respect to the ownership and disposition of H Shares or ADSs. We urge you to consult your own tax advisor regarding your

particular circumstances and the U.S. federal income and estate tax consequences to you of owning and disposing of H Shares or ADSs, as well as any tax consequences arising under the laws of any state, local, or foreign or other tax jurisdiction and the possible effects of changes in U.S. federal or other tax laws.

This summary is directed solely to persons who hold their H Shares or ADSs as capital assets within the meaning of Section 1221 of the Code, which generally means as property held for investment. For purposes of this discussion, the term “U.S. Holder” means a beneficial owner of H Shares or ADSs that is any of the following:

- a citizen or resident of the United States or someone treated as a U.S. citizen or resident for U.S. federal income tax purposes;
- a corporation (or other entity taxable as a corporation for U.S. federal income tax purposes) created or organized in or under the laws of the United States, any state thereof, or the District of Columbia;
- an estate, the income of which is subject to U.S. federal income taxation regardless of its source;
- a trust if a U.S. court can exercise primary supervision over the trust’s administration and one or more U.S. persons have the authority to control all substantial decisions of the trust; or
- a trust in existence on August 20, 1996 that has a valid election in effect under applicable Treasury Regulations to be treated as a U.S. person.

The term “Non-U.S. Holder” means a beneficial owner of H Shares or ADSs that is not a U.S. Holder. As described in “Taxation of Non-U.S. Holders” below, the tax consequences to a Non-U.S. Holder may differ substantially from the tax consequences to a U.S. Holder.

If a partnership (including for this purpose any entity treated as a partnership for U.S. federal income tax purposes) is a beneficial owner of H Shares or ADSs, the U.S. federal income tax consequences to a partner in the partnership will generally depend on the status of the partner and the activities of the partnership. A holder of H Shares or ADSs that is a partnership and the partners in such partnership should consult their own tax advisors regarding the U.S. federal income tax consequences of the ownership and disposition of H Shares or ADSs.

ADSs

As relates to the ADSs, this discussion is based in part upon the representations of the depository and the assumption that each obligation in the deposit agreement and any related agreement will be performed in accordance to its terms.

Generally, a holder of ADSs will be treated as the owner of the underlying H Shares represented by those ADSs for U.S. federal income tax purposes. Accordingly, no gain or loss will be recognized if the holder exchanges ADSs for the underlying H Shares represented by those ADSs. The holder’s adjusted tax basis in the H Shares will be the same as the adjusted tax basis of the ADSs surrendered in exchange therefor, and the holding period for the H Shares will include the holding period for the surrendered ADSs.

TAXATION OF U.S. HOLDERS

The discussion in “Distributions on H Shares or ADSs” and “Dispositions of H Shares or ADSs” below assumes that we will not be treated as a passive foreign investment company (“PFIC”) for U.S. federal income tax purposes. For a discussion of the rules that apply if we are treated as a PFIC, see the discussion in “Passive Foreign Investment Company” below.

Distributions on H Shares or ADSs

General. Subject to the discussion in “Passive Foreign Investment Company” below, if you actually or constructively receive a distribution on H Shares or ADSs, you must include the distribution in gross income as a taxable dividend on the date of your (or in the case of ADSs, the depository’s) receipt of the distribution, but only to the extent of our current or accumulated earnings and profits, as calculated under U.S. federal income tax principles. Such amount must be included without reduction for any Chinese tax withheld. Dividends paid by us generally will not be eligible for the dividends received deduction allowed to corporations with respect to dividends received from certain domestic corporations. Dividends paid by us may or may not be eligible for preferential rates applicable to qualified dividend income, as described below.

To the extent a distribution exceeds our current and accumulated earnings and profits, it will be treated first as a non-taxable return of capital to the extent of your adjusted tax basis in the H Shares or ADSs, and thereafter as capital gain. Preferential tax rates for long-term capital gain may be applicable to non-corporate U.S. Holders.

We do not intend to calculate our earnings and profits under U.S. federal income tax principles. Therefore, you should expect that a distribution will generally be reported as a dividend even if that distribution would otherwise be treated as a non-taxable return of capital or as capital gain under the rules described above.

Qualified Dividend Income. With respect to non-corporate U.S. Holders (i.e., individuals, trusts, and estates), for taxable years beginning before January 1, 2011, dividends that are treated as qualified dividend income (“QDI”) are taxable at a maximum tax rate of 15%. Among other requirements, dividends generally will be treated as QDI if either (i) our H Shares or ADSs are readily tradable on an established securities market in the United States, or (ii) we are eligible for the benefits of a comprehensive income tax treaty with the United States which includes an information exchange program and which is determined to be satisfactory by the U.S. Treasury. It is expected that our ADSs will be “readily tradable” as a result of being listed on the New York Stock Exchange.

In addition, for dividends to be treated as QDI, we must not be a PFIC (as discussed below) for either the taxable year in which the dividend was paid or the preceding taxable year. We do not believe that we will be a PFIC for our current taxable year. However, please see the discussion under “Passive Foreign Investment Company” below. Additionally, in order to qualify for QDI treatment, you generally must have held the H Shares or ADSs for more than 60 days during the 121-day period beginning 60 days prior to the ex-dividend date. However, your holding period will be reduced for any period during which the risk of loss is diminished.

Moreover, a dividend will not be treated as QDI to the extent you are under an obligation (whether pursuant to a short sale or otherwise) to make related payments with respect to positions in substantially similar or related property. Since the QDI rules are complex, you should consult your own tax advisor regarding the availability of the preferential tax rates for dividends paid on H Shares or ADSs.

Foreign Currency Distributions. A dividend paid in foreign currency (e.g., Hong Kong dollars) must be included in your income as a U.S. dollar amount based on the exchange rate in effect on the date such dividend is received, regardless of whether the payment is in fact converted to U.S. dollars. If the dividend is converted to U.S. dollars on the date of receipt, you generally will not recognize a foreign currency gain or loss. However, if you convert the foreign currency to U.S. dollars on a later date, you must include in income any gain or loss resulting from any exchange rate fluctuations. The gain or loss will be equal to the difference between (i) the U.S. dollar value of the amount you included in income when the dividend was received and (ii) the amount that you receive on the conversion of the foreign currency to U.S. dollars. Such gain or loss will generally be ordinary income or loss and U.S. source for U.S. foreign tax credit purposes.

In-Kind Distributions. Distributions to you of new H Shares or ADSs or rights to subscribe for new H Shares or ADSs that are received as part of a pro rata distribution to all of our shareholders will not be subject to U.S. federal income tax. The adjusted tax basis of the new H Shares or ADSs or rights so received will be determined by allocating your adjusted tax basis in the old H Shares or ADSs between the old H Shares or ADSs and the new H Shares or ADSs or rights received, based on their relative fair market values on the date of distribution. However, in the case of a distribution of rights to subscribe for H Shares or ADSs, the adjusted tax basis of the rights will be zero if the fair market value of the rights is less than 15% of the fair market value of the old H Shares or ADSs on the date of distribution and you do not make an election to determine the adjusted tax basis of the rights by allocation as described above. Your holding period for the new H Shares or ADSs or rights will generally include the holding period for the old H Shares or ADSs on which the distribution was made.

Foreign Tax Credits. Subject to certain conditions and limitations, any Chinese taxes paid on or withheld from distributions from us and not refundable to you may be credited against your U.S. federal income tax liability or, alternatively, may be deducted from your taxable income. This election is made on a year-by-year basis and applies to all foreign taxes paid by you or withheld from you that year. No Chinese withholding tax currently is imposed on dividends on the H Shares and ADSs, although Chinese withholding taxes could be imposed in the future.

Distributions will constitute foreign source income for foreign tax credit limitation purposes. The foreign tax credit limitation is calculated separately with respect to two specific classes of income. For this purpose, distributions characterized as dividends distributed by us will generally constitute “passive category income” or, in the case of certain U.S. Holders, “general category income.” Special limitations may apply if a dividend is treated as QDI (as defined above).

Special rules may apply to electing individuals whose foreign source income during the taxable year consists entirely of “qualified passive income” and whose creditable foreign taxes paid or accrued during the taxable year do not exceed \$300 (\$600 in the case of a joint return).

In certain circumstances, a U.S. Holder that (i) has held H Shares or ADSs for less than a specified minimum period during which it is not protected from risk of loss, (ii) is obligated to make payments related to the dividends, or (iii) holds H Shares or ADSs in arrangements in which the U.S. Holder’s expected economic profit, after foreign taxes, is insubstantial, will not be allowed a foreign tax credit for foreign taxes imposed on dividends paid on H Shares or ADSs.

Since the rules governing foreign tax credits are complex, you should consult your own tax advisor regarding the availability of foreign tax credits in your particular circumstances.

The U.S. Treasury has expressed concerns that parties to whom ADSs are pre-released may be taking actions that are inconsistent with the claiming of foreign tax credits by U.S. Holders of ADSs. Such actions would also be inconsistent with the claiming of the preferential tax rates applicable to QDI, as defined above. Accordingly, the creditability of any Chinese taxes and the availability of such preferential tax rates could be affected by future actions that may be taken by the U.S. Treasury or parties to whom ADSs are pre-released.

Dispositions of H Shares or ADSs

Subject to the discussion in “Passive Foreign Investment Company” below, you generally will recognize taxable gain or loss realized on the sale or other taxable disposition of H Shares or ADSs equal to the difference between the U.S. dollar value of (i) the amount realized on the disposition (i.e., the amount of cash plus the fair market value of any property received), and (ii) your adjusted tax basis in the H Shares or ADSs. Such gain or loss will be capital gain or loss.

If you have held the H Shares or ADSs for more than one year at the time of disposition, such capital gain or loss will be long-term capital gain or loss. Preferential tax rates for long-term capital gain (currently, with a maximum rate of 15% for taxable years beginning before January 1, 2011) will apply to non-corporate U.S. Holders. If you have held the H Shares or ADSs for one year or less, such capital gain or loss will be short-term capital gain or loss taxable as ordinary income at your marginal income tax rate. The deductibility of capital losses is subject to limitations.

Generally, any gain or loss recognized will not give rise to foreign source income for U.S. foreign tax credit purposes.

You should consult your own tax advisor regarding the U.S. federal income tax consequences if you receive currency other than U.S. dollars upon the disposition of H Shares or ADSs.

Passive Foreign Investment Company

We generally will be a PFIC under Section 1297 of the Code if, for a taxable year, either (a) 75% or more of our gross income for such taxable year is passive income (the “income test”) or (b) 50% or more of the average percentage, generally determined by fair market value, of our assets during such taxable year either produce passive income or are held for the production of passive income (the “asset test”). “Passive income” includes, for example, dividends, interest, certain rents and royalties, certain gains from the sale of stock and securities, and certain gains from commodities transactions.

Certain “look through” rules apply for purposes of the income and asset tests described above. If we own, directly or indirectly, 25% or more of the total value of the outstanding shares of another corporation, we will be treated as if we (a) held directly a proportionate share of the other corporation’s assets, and (b) received directly a proportionate share of the other corporation’s income. In addition, passive income does not include any interest, dividends, rents, or royalties that are received or accrued by us from a “related person” (as defined in Section 954(d)(3) of the Code), to the extent such items are properly allocable to income of such related person that is not passive income.

Under the income and asset tests, whether or not we are a PFIC will be determined annually based upon the composition of our income and the composition and valuation of our assets, all of which are subject to change. In determining that we are not a PFIC, we

are relying on our projected revenues and projected capital expenditures. If our actual revenues and capital expenditures do not match our projections, we may become a PFIC. For example, if we do not spend enough of the cash (a passive asset) we raise from any financing transactions we may undertake, the relative percentage of our passive assets will increase. In addition, our determination is based on a current valuation of our assets, including goodwill. In calculating goodwill, we have valued our total assets based on our market capitalization, determined using the market price of our H Shares and ADSs. Such market price may fluctuate. If our market capitalization is less than anticipated or subsequently declines, this will decrease the value of our goodwill and we may become a PFIC. Furthermore, we have made a number of assumptions regarding the amount of value allocable to goodwill. We believe our valuation approach is reasonable. However, it is possible that the IRS will challenge the valuation of our goodwill, which may result in our being a PFIC.

We do not believe that we are currently a PFIC. However, because the PFIC determination is highly fact intensive and made at the end of each taxable year, there can be no assurance that we will not be a PFIC for the current or any future taxable year or that the IRS will not challenge our determination concerning our PFIC status.

Default PFIC Rules under Section 1291 of the Code. If we are a PFIC, the U.S. federal income tax consequences to a U.S. Holder of the ownership and disposition of H Shares or ADSs will depend on whether such U.S. Holder makes an election to treat us as a qualified electing fund (“QEF”) under Section 1295 of the Code (a “QEF Election”) or a mark-to-market election under Section 1296 of the Code (a “Mark-to-Market Election”). A U.S. Holder owning H Shares or ADSs while we were or are a PFIC that has not made either a QEF Election or a Mark-to-Market Election will be referred to in this summary as a “Non-Electing U.S. Holder.”

If you are a Non-Electing U.S. Holder, you will be subject to the default tax rules of Section 1291 of the Code with respect to:

- any “excess distribution” paid on H Shares or ADSs, which means the excess (if any) of the total distributions received by you during the current taxable year over 125% of the average distributions received by you during the three preceding taxable years (or during the portion of your holding period for the H Shares or ADSs prior to the current taxable year, if shorter); and
- any gain recognized on the sale or other taxable disposition (including a pledge) of H Shares or ADSs.

Under these default tax rules:

- any excess distribution or gain will be allocated ratably over your holding period for the H Shares or ADSs;
- the amount allocated to the current taxable year and any period prior to the first day of the first taxable year in which we were a PFIC will be treated as ordinary income in the current taxable year;
- the amount allocated to each of the other years will be treated as ordinary income and taxed at the highest applicable tax rate in effect for that year; and

-
- the resulting tax liability from any such prior years will be subject to the interest charge applicable to underpayments of tax.

In addition, notwithstanding any election you may make, dividends that you receive from us will not be eligible for the preferential tax rates applicable to QDI (as discussed above in “Distributions on H Shares or ADSs”) if we are a PFIC either in the taxable year of the distribution or the preceding taxable year, but will instead be taxable at rates applicable to ordinary income.

Special rules for Non-Electing U.S. Holders will apply to determine U.S. foreign tax credits with respect to foreign taxes imposed on distributions on H Shares or ADSs.

If we are a PFIC for any taxable year during which you hold H Shares or ADSs, we will continue to be treated as a PFIC with respect to you for all succeeding years during which you hold H Shares or ADSs, regardless of whether we actually continue to be a PFIC. You may terminate this deemed PFIC status by electing to recognize gain (which will be taxed under the default tax rules of Section 1291 of the Code discussed above) as if your H Shares or ADSs had been sold on the last day of the last taxable year for which we were a PFIC.

If we are a PFIC in any year with respect to you, you will be required to file an annual return on IRS Form 8621 regarding distributions received on H Shares or ADSs and any gain realized on the disposition of H Shares or ADSs.

QEF Election. If you make a QEF Election, you generally will not be subject to the default rules of Section 1291 of the Code discussed above. Instead, you will be subject to current U.S. federal income tax on your pro rata share of our ordinary earnings and net capital gain, regardless of whether such amounts are actually distributed to you by us. However, you can make a QEF Election only if we agree to furnish you annually with certain tax information, and we currently do not intend to prepare or provide such information.

Mark-to-Market Election. U.S. Holders may make a Mark-to-Market Election, but only if the H Shares or ADSs are marketable stock. The H Shares or ADSs will be “marketable stock” as long as they are regularly traded on a qualified exchange. Stock is considered “regularly traded” for any calendar year during which it is traded (other than in de minimis quantities) on at least 15 days during each calendar quarter. Qualified exchanges include (a) a national securities exchange that is registered with the Securities and Exchange Commission, (b) the national market system established pursuant to section 11A of the Securities and Exchange Act of 1934, and (c) a foreign securities exchange that is regulated or supervised by a governmental authority of the country in which the market is located, provided that (i) such foreign exchange has trading volume, listing, financial disclosure, surveillance, and other requirements and the laws of the country in which such foreign exchange is located, together with the rules of such foreign exchange, ensure that such requirements are actually enforced, and (ii) the rules of such foreign exchange effectively promote active trading of listed stocks.

Since the H Shares are listed on a foreign exchange (i.e., the Stock Exchange of Hong Kong Limited) and the IRS has yet to identify specific foreign exchanges that are qualified for this purpose, there can be no assurances that the H Shares will be marketable stock and will be regularly traded. As for the ADSs, they will be “marketable stock” as long as they remain listed on the New York Stock Exchange and are regularly traded. There can be no assurances, however, that the ADSs will be treated, or continue to be treated, as regularly traded.

If you make a Mark-to-Market Election, you generally will not be subject to the default rules of Section 1291 of the Code discussed above. Rather, you generally will be required to recognize ordinary income for any increase in the fair market value of the ADSs for each taxable year that we are a PFIC. You will also be allowed to deduct as an ordinary loss any decrease in the fair market value to the extent of net marked-to-market gain previously included in prior years. Your adjusted tax basis in the ADSs will be adjusted to reflect the amount included or deducted.

The Mark-to-Market Election will be effective for the taxable year for which the election is made and all subsequent taxable years, unless the ADSs cease to be marketable stock or the IRS consents to the revocation of the election. You should consult your own tax advisor regarding the availability of, and procedure for making, a Mark-to-Market Election.

Since the PFIC rules are complex, you should consult your own tax advisor regarding them and how they may affect the U.S. federal income tax consequences of the ownership and disposition of H Shares or ADSs.

Information Reporting and Backup Withholding

Generally, information reporting requirements will apply to distributions on H Shares or ADSs or proceeds from the disposition of H Shares or ADSs paid within the United States (and, in certain cases, outside the United States) to a U.S. Holder unless such U.S. Holder is an exempt recipient, such as a corporation. Furthermore, backup withholding (currently at 28%) may apply to such amounts unless such U.S. Holder (i) is an exempt recipient that, if required, establishes its right to an exemption, or (ii) provides its taxpayer identification number, certifies that it is not currently subject to backup withholding, and complies with other applicable requirements. A U.S. Holder may generally avoid backup withholding by furnishing a properly completed IRS Form W-9.

Backup withholding is not an additional tax. Rather, amounts withheld under the backup withholding rules may be credited against your U.S. federal income tax liability. Furthermore, you may obtain a refund of any excess amounts withheld by filing an appropriate claim for refund with the IRS and furnishing any required information in a timely manner.

TAXATION OF NON-U.S. HOLDERS

Distributions on H Shares or ADSs

Subject to the discussion in “Information Reporting and Backup Withholding” below, as a Non-U.S. Holder, you generally will not be subject to U.S. federal income tax, including withholding tax, on distributions received on H Shares or ADSs, unless the distributions are effectively connected with your conduct of a trade or business in the United States and (if an applicable income tax treaty so requires) attributable to a permanent establishment that you maintain in the United States.

If distributions are effectively connected with a U.S. trade or business and (if applicable) attributable to a U.S. permanent establishment, you generally will be subject to tax on such distributions in the same manner as a U.S. Holder, as described in “Taxation of U.S. Holders – Distributions on H Shares or ADSs” above. In addition, any such distributions received by a corporate Non-U.S. Holder may also, under certain circumstances, be subject to an additional “branch profits tax” at a 30% rate or such lower rate as may be specified by an applicable income tax treaty.

Dispositions of H Shares or ADSs

Subject to the discussion in “Information Reporting and Backup Withholding” below, as a Non-U.S. Holder, you generally will not be subject to U.S. federal income tax, including withholding tax, on any gain recognized on a sale or other taxable disposition of H Shares or ADSs, unless (i) the gain is effectively connected with your conduct of a trade or business in the United States and (if an applicable income tax treaty so requires) attributable to a permanent establishment that you maintain in the United States, or (ii) you are an individual and are present in the United States for at least 183 days in the taxable year of the disposition, and certain other conditions are met.

If you meet the test in clause (i) above, you generally will be subject to tax on any gain that is effectively connected with your conduct of a trade or business in the United States in the same manner as a U.S. Holder, as described in “Taxation of U.S. Holders – Dispositions of H Shares or ADSs” above. Effectively connected gain realized by a corporate Non-U.S. Holder may also, under certain circumstances, be subject to an additional “branch profits tax” at a 30% rate or such lower rate as may be specified by an applicable income tax treaty.

If you meet the test in clause (ii) above, you generally will be subject to tax at a 30% rate on the amount by which your U.S. source capital gain exceeds your U.S. source capital loss.

Information Reporting and Backup Withholding

Payments to Non-U.S. Holders of distributions on, or proceeds from the disposition of, H Shares or ADSs are generally exempt from information reporting and backup withholding. However, a Non-U.S. Holder may be required to establish that exemption by providing certification of non-U.S. status on an appropriate IRS Form W-8.

Backup withholding is not an additional tax. Rather, amounts withheld under the backup withholding rules may be credited against your U.S. federal income tax liability. Furthermore, you may obtain a refund of any excess amounts withheld by filing an appropriate claim for refund with the IRS and furnishing any required information in a timely manner.

F. Dividends and Paying Agents.

Not applicable.

G. Statement by Experts.

Not applicable.

H. Documents on Display.

We are subject to the periodic reporting and other informational requirements of the Securities Exchange Act of 1934, as amended, or the Exchange Act. Under the Exchange Act, we are required to file reports and other information with the Securities and Exchange Commission. Specifically, we are required to file annually a Form 20-F no later than six months after the close of each fiscal year, which is December 31 of each year. Copies of reports and other information, when so filed, may be inspected without charge and may be obtained at prescribed rates at the public reference facilities maintained by the Securities and Exchange Commission at Room 1024, Judiciary Plaza, 450 Fifth Street, N.W., Washington, D.C. 20549. You can request copies of these documents upon payment of a duplicating fee, by writing to the SEC. Please call the SEC at 1-800-SEC-0330 for further information

loans									
In U.S. Dollars	14,526	14,526	12,071	—	—	—	41,123	38,176	
Average interest rate	1.80%	1.80%	1.80%	—	—	—	1.80%	—	
Variable rate bank and other loans									
In U.S. Dollars	2,300,037	397,112	—	—	—	—	2,697,149	2,697,149	
Average interest rate ⁽¹⁾	5.03%	4.99%	—	—	—	—	5.02%	—	
In RMB	1,601,500	108,500	810,000	—	—	—	2,520,000	2,504,885	
Average interest rate ⁽¹⁾	5.43%	5.22%	5.18%	—	—	—	5.34%	—	

(1) The average interest rates for variable rate bank and other loans are calculated based on the year end indices.

Exchange Rate Sensitivity

We are also exposed to foreign currency exchange rate risk as a result of our foreign currency denominated long-term debt and, to a limited extent, cash and cash equivalents denominated in foreign currencies. We have no program of foreign currency hedging activities and did not engage in any foreign currency hedging activities in 2006 or 2005.

The following table provides information, by maturity date, regarding our foreign currency exchange rate sensitive financial instruments, which consist of cash and cash equivalents, short-term and long-term debt obligations as of December 31, 2006 and 2005.

	As of December 31, 2006						Total Recorded Amount	Fair Value
	2007	2008	2009	2010	2011	Thereafter		
(RMB equivalent in thousands, except interest rates)								
On-balance sheet financial instruments								
Cash and cash equivalents:								
In Hong Kong Dollars	11,834	—	—	—	—	—	11,834	11,834
In U.S. Dollars	40,121	—	—	—	—	—	40,121	40,121
In Euro	1,201	—	—	—	—	—	1,201	1,201
In Japanese Yen	4	—	—	—	—	—	4	4
Debt:								
Fixed rate bank and other loans in U.S. Dollars	14,056	9,654	—	—	—	—	23,710	22,410
Average interest rate	1.80%	1.80%	—	—	—	—	1.80%	—
Variable rate bank and other loans in U.S. Dollars	2,001,726	—	—	—	—	—	2,001,726	2,001,726
Average interest rate ⁽¹⁾	5.90%	—	—	—	—	—	5.90%	—
Interest free bank and other loans in U.S. Dollars	2,811	2,811	2,811	2,811	2,811	—	14,055	11,783

(1) The average interest rates for variable rate bank and other loans are calculated based on the year end indices.

As of December 31, 2005

	2006	2007	2008	2009	2010	Thereafter	Total Recorded Amount	Fair Value
(RMB equivalent in thousands, except interest rates)								
On-balance sheet financial instruments								
Cash and cash equivalents:								
In Hong Kong Dollars	46,095	—	—	—	—	—	46,095	46,095
In U.S. Dollars	55,329	—	—	—	—	—	55,329	55,329
In Swiss Francs	792	—	—	—	—	—	792	792
In Euro	1,111	—	—	—	—	—	1,111	1,111
In Japanese Yen	2	—	—	—	—	—	2	2
Debt:								
Fixed rate bank and other loans								
In U.S. Dollars	14,526	14,526	12,071	—	—	—	41,123	38,176
Average interest rate	1.80%	1.80%	1.80%	—	—	—	1.80%	—
Variable rate bank and other loans								
In U.S. Dollars	2,300,037	397,112	—	—	—	—	2,697,149	2,697,149
Average interest rate ⁽¹⁾	5.03%	4.99%	—	—	—	—	5.02%	—
Interest free bank and other loans								
In U.S. Dollars	2,905	2,905	2,905	2,905	2,905	2,906	17,431	14,353

(1) The average interest rates for variable rate bank and other loans are calculated based on the year end indices.

ITEM 12. DESCRIPTION OF SECURITIES OTHER THAN EQUITY SECURITIES.

Not applicable.

PART II

ITEM 13. DEFAULTS, DIVIDEND ARREARAGES AND DELINQUENCIES.

None.

ITEM 14. MATERIAL MODIFICATIONS TO THE RIGHTS OF SECURITY HOLDERS AND USE OF PROCEEDS.

None.

ITEM 15. CONTROLS AND PROCEDURES

A. Evaluation of disclosure controls and procedures.

The term “disclosure controls and procedures” is defined in Rules 13a-15(e) and 15d-15(e) of the Exchange Act. These rules refer to the controls and other procedures of a company that are designed to ensure that information required to be disclosed by a company in the reports that it files under the Exchange Act is recorded, processed, summarized and reported within required time periods. This includes controls and procedures designed to ensure that information required to be disclosed is accumulated and communicated to our management, including our principal executive officer or officers and principal financial officer or officers, to allow timely decisions regarding required disclosure.

We maintain a written policy adopted by our board of directors that governs the collection, coordination and disclosure of information to our shareholders, the public and to governmental and other regulatory bodies. All such disclosures are coordinated by the Secretary and subject to execution by either the Chairman of the Board or, for disclosures by our Supervisory Board, the Chairman of the Supervisory Board. Under the policy, all material issues must be disclosed and our disclosures must be true, accurate, complete and timely without any false or misleading statements. Each of our departments and subsidiaries have their own supplemental policies which may be both written and unwritten.

Our chief executive officer and our chief financial officer have evaluated the effectiveness of our disclosure controls and procedures as of the end of the period covered by this report (the “Evaluation Date”), and they have concluded that, as of the Evaluation Date, such controls and procedures were effective at ensuring that required information will be disclosed on a timely basis in our reports filed under the Exchange Act.

Subsequent to the date of the evaluation described above, we have not made any significant changes, including corrective actions with regard to significant deficiencies or material weaknesses, in our internal controls or in other factors that could significantly affect these controls.

Although we believe our existing disclosure controls and procedures are adequate to enable us to comply with our disclosure obligations, we do not expect that our disclosure controls and procedures or our other internal controls can prevent all error and all fraud or that our evaluation of these controls and procedures can provide absolute assurance that all control issues and instances of fraud, if any, have been detected. The benefits of controls and procedures must be considered relative to their costs, and the design of any system of controls is based in part upon assumptions about the likelihood of future events. There can be no assurance that any design will succeed in achieving its stated goals under all potential future conditions. Over time, controls and procedures may become inadequate because of changes in conditions, or the degree of compliance with the policies or procedures may deteriorate. Because of these and other inherent limitations in controls and procedures, misstatements or omissions due to error or fraud may occur and not be detected. In part to mitigate this risk, we plan to further refine our controls and procedures in light of developing practice in this area and emerging standards and mandatory rules.

B. Management’s report on internal control over financial reporting.

Management of the company is responsible for establishing and maintaining adequate internal control over financial reporting as defined in Rules 13a-15(f) and 15d-15(f) under the Securities Exchange Act of 1934. The company’s internal control over financial reporting is designed to provide reasonable assurance regarding the reliability of financial reporting and the preparation of financial statements for external purposes in accordance with generally accepted accounting principles. The company’s internal control over financial reporting includes those policies and procedures that:

(i) pertain to the maintenance of records that, in reasonable detail, accurately and fairly reflect the transactions and dispositions of the assets of the company;

(ii) provide reasonable assurance that transactions are recorded as necessary to permit preparation of financial statements in accordance with generally accepted accounting principles, and that receipts and expenditures of the company are being made only in accordance with authorizations of management and directors of the company; and

(iii) provide reasonable assurance regarding prevention or timely detection of unauthorized acquisition, use or disposition of the company’s assets that could have a material effect on the financial statements.

Because of its inherent limitations, internal control over financial reporting may not prevent or detect misstatements. Also, projections of any evaluation of effectiveness to future periods are subject to the risk that controls may become inadequate because of changes in conditions, or that the degree of compliance with the policies or procedures may deteriorate.

Management assessed the effectiveness of the company’s internal control over financial reporting as of December 31, 2006.

In making this assessment, management used the criteria set forth by the Committee of Sponsoring Organizations of the Treadway Commission (COSO) in Internal Control-Integrated Framework.

Based on our assessment and those criteria, management believes that the company maintained effective internal control over financial reporting as of December 31, 2006.

Management's assessment of the effectiveness of the company's internal control over financial reporting as of December 31, 2006 has been audited by KPMG, an independent registered public accounting firm, as stated in their report appearing below.

C. Attestation Report of Independent Registered Public Accounting Firm.

The Board of Directors and Shareholders of
Sinopec Shanghai Petrochemical Company Limited:

We have audited management's assessment, included in the accompanying Management's Report on Internal Control over Financial Reporting, that Sinopec Shanghai Petrochemical Company Limited and subsidiaries (the "Group") maintained effective internal control over financial reporting as of December 31, 2006, based on criteria established in *Internal Control—Integrated Framework* issued by the Committee of Sponsoring Organizations of the Treadway Commission (COSO). The Group's management is responsible for maintaining effective internal control over financial reporting and for its assessment of the effectiveness of internal control over financial reporting. Our responsibility is to express an opinion on management's assessment and an opinion on the effectiveness of the Group's internal control over financial reporting based on our audit.

We conducted our audit in accordance with the standards of the Public Company Accounting Oversight Board (United States). Those standards require that we plan and perform the audit to obtain reasonable assurance about whether effective internal control over financial reporting was maintained in all material respects. Our audit included obtaining an understanding of internal control over financial reporting, evaluating management's assessment, testing and evaluating the design and operating effectiveness of internal control, and performing such other procedures as we considered necessary in the circumstances. We believe that our audit provides a reasonable basis for our opinion.

A company's internal control over financial reporting is a process designed to provide reasonable assurance regarding the reliability of financial reporting and the preparation of financial statements for external purposes in accordance with generally accepted accounting principles. A company's internal control over financial reporting includes those policies and procedures that (1) pertain to the maintenance of records that, in reasonable detail, accurately and fairly reflect the transactions and dispositions of the assets of the company; (2) provide reasonable assurance that transactions are recorded as necessary to permit preparation of financial statements in accordance with generally accepted accounting principles, and that receipts and expenditures of the company are being made only in accordance with authorizations of management and directors of the company; and (3) provide reasonable assurance regarding prevention or timely detection of unauthorized acquisition, use, or disposition of the company's assets that could have a material effect on the financial statements.

Because of its inherent limitations, internal control over financial reporting may not prevent or detect misstatements. Also, projections of any evaluation of effectiveness to future periods are subject to the risk that controls may become inadequate because of changes in conditions, or that the degree of compliance with the policies or procedures may deteriorate.

In our opinion, management's assessment that the Group maintained effective internal control over financial reporting as of December 31, 2006, is fairly stated, in all material respects, based on criteria established in Internal Control—Integrated Framework issued by COSO. Also, in our opinion, the Group maintained, in all material respects, effective internal control over financial reporting as of December 31, 2006, based on criteria established in Internal Control—Integrated Framework issued by COSO.

We also have audited, in accordance with the standards of the Public Company Accounting Oversight Board (United States), the consolidated balance sheets of the Group as of December 31, 2005 and 2006, and the related consolidated statements of income, cash flows and equity for each of the years in the three-year period ended December 31, 2006, and our report dated March 29, 2007 expressed an unqualified opinion on those consolidated financial statements.

/S/ KPMG
Hong Kong, China

March 29, 2007

D. Changes in internal control over financial reporting.

For the year ended December 31, 2006, there have been no significant changes to our internal controls over financial reporting that have materially affected, or are reasonably likely to materially affect our internal control over financial reporting.

ITEM 16A.AUDIT COMMITTEE FINANCIAL EXPERT

We currently have an audit committee financial expert, Chen Xinyuan, serving on our audit committee and he is an independent director as defined in 17 CFR 240.10A-3.

ITEM 16B.CODE OF ETHICS

We have not adopted a code of ethics as defined by the applicable U.S. securities regulations that applies to our principal executive officer, principal financial officer, principal accounting officer or controller, or persons performing similar functions since it is not a customary practice for a PRC company to adopt such code of ethics.

**I PRINCIPAL ACCOUNTANT FEES AND SERVICES
TEM 16C.**

The following table summarizes the fees charged by KPMG, our principal accountant, for certain services rendered to us during 2005 and 2006.

	For the year ended December 31,	
	(in thousands of RMB)	
	2005	2006
Audit fees (1)	6,150	7,721
Audit-related fees (2)	—	—
Tax fees (3)	—	—
All other fees (4)	—	300
Total	6,150	8,021

-
- (1) "Audit fees" means the aggregate fees billed in each of the fiscal years listed for professional services rendered by our principal auditors for the audit of our annual financial statements.
 - (2) "Audit-related fees" means the aggregate fees billed in each of the fiscal years listed for assurance and related services rendered by our principal auditors for the audit of our financial information.
 - (3) "Tax fees" means the aggregate fees billed in each of the fiscal years listed for professional services rendered by our principal auditors for tax compliance, tax advice and tax planning.
 - (4) "All other fees" means the aggregate fees billed in each of the fiscal years listed for products and services provided by the our principal accountant, other than the services reported under audit fees, audit-related fees and tax fees.

Audit Committee Pre-approval Policies and Procedures

Our audit committee has adopted procedures which set forth the manner in which the committee will review and approve all audit and non-audit services to be provided by KPMG. The pre-approval procedures are as follows:

- Any audit or non-audit service to be provided to us by the independent accountant must be (i) pre-approved by the audit committee; or (ii) pre-approved by one or several committee members designated by the committee and rectified by the audit committee.

ITEM 16D.EXEMPTIONS FROM THE LISTING STANDARDS FOR AUDIT COMMITTEES.

We have not been granted an exemption from the applicable listing standards for the audit committee of our board of directors.

ITEM 16E.PURCHASES OF EQUITY SECURITIES BY THE ISSUER AND AFFILIATED PURCHASERS.

None.

PART III

ITEM 17.FINANCIAL STATEMENTS.

We have elected to provide the financial statements and related information specified in Item 18 in lieu of the information called for by this Item 17. See pages F-1 to F-63.

Separate financial statements and notes thereto for Shanghai Secco Petrochemical Co., Ltd. are being filed pursuant to Rule 3-09 of Regulation S-X. See pages F-64 to F-94.

ITEM 18.FINANCIAL STATEMENTS.

See pages F-1 to F-94 incorporated herein by reference.

ITEM 19.EXHIBITS

- 12.1 Certification of Chairman Required by Rule 13a-14(a).
- 12.2 Certification of Chief Financial Officer Required by Rule 13a-14(a).
- 13.1 Certification of Chairman Required by Rule 13a-14(b) and Section 1350 of Chapter 63 of Title 18 of the United States Code.
- 13.2 Certification of Chief Financial Officer Required by Rule 13a-14(b) and Section 1350 of Chapter 63 of Title 18 of the United States Code.

SIGNATURES

The registrant hereby certifies that it meets all of the requirements for filing on Form 20-F and that it has duly caused and authorized the undersigned to sign this annual report on its behalf.

**SINOPEC SHANGHAI
PETROCHEMICAL COMPANY
LIMITED**

Date: June 28, 2007

/s/ Rong Guangdao

Rong Guangdao, Chairman

Sinopec Shanghai Petrochemical Company Limited
Index
Years Ended December 31, 2004, 2005 and 2006

Consolidated Financial Statements of Sinopec Shanghai Petrochemical Company Limited

	<u>Page</u>
<u>Report of Independent Registered Public Accounting Firm</u>	F-2
<u>Consolidated Balance Sheets</u> <u>December 31, 2005 and 2006</u>	F-3
<u>Consolidated Statements of Income</u> <u>Years Ended December 31, 2004, 2005 and 2006</u>	F-4
<u>Consolidated Statements of Cash Flows</u> <u>Years Ended December 31, 2004, 2005 and 2006</u>	F-5
<u>Consolidated Statements of Equity</u> <u>Years Ended December 31, 2004, 2005 and 2006</u>	F-7
<u>Notes to Consolidated Financial Statements</u>	F-8
<u>Financial Statements of Shanghai Secco Petrochemical Company Limited (1)</u> <u>Years Ended December 31, 2004 (Unaudited), 2005 (Unaudited) and 2006</u>	F-64

-
- (1) The financial statements of Shanghai Secco Petrochemical Company Limited, an investee of Sinopec Shanghai Petrochemical Company Limited., are included in this Annual Report on Form 20-F of Sinopec Shanghai Petrochemical Company Limited to comply with Rule 3-09 of Regulation S-X of the U.S. Federal Securities Laws.

Report of Independent Registered Public Accounting Firm

The Board of Directors and Shareholders of
Sinopec Shanghai Petrochemical Company Limited:

We have audited the accompanying consolidated balance sheets of Sinopec Shanghai Petrochemical Company Limited and subsidiaries (the "Group") as of December 31, 2005 and 2006, and the related consolidated statements of income, cash flows, and equity for each of the years in the three-year period ended December 31, 2006, all expressed in Renminbi. These consolidated financial statements are the responsibility of the Group's management. Our responsibility is to express an opinion on these consolidated financial statements based on our audits.

We conducted our audits in accordance with the standards of the Public Company Accounting Oversight Board (United States). Those standards require that we plan and perform the audit to obtain reasonable assurance about whether the financial statements are free of material misstatement. An audit includes examining, on a test basis, evidence supporting the amounts and disclosures in the financial statements. An audit also includes assessing the accounting principles used and significant estimates made by management, as well as evaluating the overall financial statement presentation. We believe that our audits provide a reasonable basis for our opinion.

In our opinion, the consolidated financial statements referred to above present fairly, in all material respects, the financial position of Sinopec Shanghai Petrochemical Company Limited and subsidiaries as of December 31, 2005 and 2006, and the results of their operations and their cash flows for each of the years in the three-year period ended December 31, 2006, in conformity with International Financial Reporting Standards promulgated by the International Accounting Standards Board.

International Financial Reporting Standards vary in certain significant respects from accounting principles generally accepted in the United States of America. Information relating to the nature and effect of such differences is presented in Note 34 to the consolidated financial statements.

We have also audited, in accordance with the standards of the Public Company Accounting Oversight Board (United States), the effectiveness of the Group's internal control over financial reporting as of December 31, 2006, based on criteria established in Internal Control-Integrated Framework issued by the Committee of Sponsoring Organizations of the Treadway Commission (COSO), and our report dated March 29, 2007 expressed an unqualified opinion on management's assessment of, and the effective operation of, internal control over financial reporting.

KPMG

Hong Kong, China
March 29, 2007

SINOPEC SHANGHAI PETROCHEMICAL COMPANY LIMITED
AND SUBSIDIARIES
Consolidated Balance Sheets
As of December 31, 2005 and 2006
(Amounts in thousands)

	Note	December 31,	
		2005	2006
		Renminbi	Renminbi
Assets			
Current assets:			
Cash and cash equivalents		1,347,237	894,650
Inventories	13	4,114,978	4,163,256
Amounts due from related companies	27	561,552	695,286
Trade debtors, net	14	252,166	358,690
Bills receivable		731,204	1,212,110
Other debtors and prepayments	15	455,043	239,114
Income tax recoverable		45,374	—
Total current assets		<u>7,507,554</u>	<u>7,563,106</u>
Non-current assets:			
Property, plant and equipment, net	16	14,651,167	13,359,862
Investment property	17	514,582	501,904
Construction in progress	18	787,376	2,008,447
Lease prepayments and other assets		507,962	603,290
Interest in associates and jointly controlled entities	19	2,130,803	2,787,795
Investments	20	665,363	528,931
Deferred tax assets	10	23,149	30,310
Goodwill	21	22,415	22,415
Total non-current assets		<u>19,302,817</u>	<u>19,842,954</u>
Total assets		<u><u>26,810,371</u></u>	<u><u>27,406,060</u></u>
Liabilities and Shareholders' Equity			
Current liabilities:			
Loans and borrowings	22	3,926,742	4,270,337
Amounts due to related companies	27	467,909	599,773
Trade creditors		963,230	1,385,577
Bills payable		68,302	7,026
Accrued expenses and other creditors		679,866	732,951
Income tax payable		26,588	34,386
Total current liabilities		<u>6,132,637</u>	<u>7,030,050</u>
Non-current liabilities:			
Deferred income		23,033	—
Loans and borrowings	22	1,477,261	1,063,654
Total non-current liabilities		<u>1,500,294</u>	<u>1,063,654</u>
Total liabilities		<u>7,632,931</u>	<u>8,093,704</u>
Shareholders' equity:			

Share capital	23	7,200,000	7,200,000
Share premium and reserves	24	<u>11,629,987</u>	<u>11,776,343</u>
Total equity attributable to equity shareholders of the Company		18,829,987	18,976,343
Minority interests		<u>347,453</u>	<u>336,013</u>
Total equity		<u>19,177,440</u>	<u>19,312,356</u>
Total liabilities and shareholders' equity		<u>26,810,371</u>	<u>27,406,060</u>

See accompanying notes to consolidated financial statements.

SINOPEC SHANGHAI PETROCHEMICAL COMPANY LIMITED
AND SUBSIDIARIES
Consolidated Statements of Income
Years ended December 31, 2004, 2005 and 2006
(Amounts in thousands, except per share data)

	Note	Years ended December 31,		
		2004 Renminbi	2005 Renminbi	2006 Renminbi
Sales	3	39,402,533	45,955,903	50,599,485
Less Sales taxes and surcharges		(738,474)	(765,689)	(681,362)
Net sales		38,664,059	45,190,214	49,918,123
Other income	4	—	632,820	282,142
Cost of sales	5	(33,223,604)	(42,887,742)	(49,182,232)
Gross profit		5,440,455	2,935,292	1,018,033
Selling and administrative expenses		(408,144)	(444,449)	(521,990)
		5,032,311	2,490,843	496,043
Other operating income	6	277,005	238,611	297,394
Other operating expenses	7	(284,164)	(201,494)	(240,530)
Income from operations		5,025,152	2,527,960	552,907
Share of (losses)/profits of associates and jointly controlled entities		(36,915)	(60,968)	576,682
Net financing costs	9	(292,008)	(179,398)	(165,389)
Income before income tax		4,696,229	2,287,594	964,200
Income tax	10	(637,061)	(366,300)	(53,238)
Net income		<u>4,059,168</u>	<u>1,921,294</u>	<u>910,962</u>
Attributable to:				
Equity shareholders of the Company		3,971,103	1,850,449	844,407
Minority interests		88,065	70,845	66,555
Net income		<u>4,059,168</u>	<u>1,921,294</u>	<u>910,962</u>
Basic earnings per share	11	<u>RMB 0.55</u>	<u>RMB 0.26</u>	<u>RMB 0.12</u>
Dividends attributable to the year	12	<u>1,440,000</u>	<u>720,000</u>	<u>288,000</u>

See accompanying notes to consolidated financial statements.

SINOPEC SHANGHAI PETROCHEMICAL COMPANY LIMITED
AND SUBSIDIARIES
Consolidated Statements of Cash Flows
For the years ended December 31, 2004, 2005 and 2006
(Amounts in thousands)

	Years ended December 31,		
	2004	2005	2006
	Renminbi	Renminbi	Renminbi
Net cash generated from operating activities (a)	4,589,711	3,943,578	1,696,615
Cash flows from investing activities:			
Interest income received	42,750	39,631	56,827
Investment income received	96,591	79,688	47,596
Capital expenditure	(2,205,957)	(1,142,927)	(2,008,779)
Proceeds from disposal of property, plant and equipment	112,949	131,845	254,843
Purchase of investments and addition of interests in associates	(650,285)	(347,170)	(54,206)
Proceeds from disposal of investments	101,461	45,691	351,178
Purchase of time deposits	(63,333)	—	—
Maturity of time deposits	225,218	4,000	—
Net cash used in investing activities	(2,340,606)	(1,189,242)	(1,352,541)
Cash flows from financing activities:			
Net proceeds from issue of corporate bonds	—	—	2,977,800
Proceeds from loans	5,214,936	9,836,199	13,936,126
Repayment of loans	(6,981,696)	(11,393,941)	(15,910,127)
Redemption of corporate bonds	—	—	(1,000,000)
Dividends paid to equity shareholders of the Company	(576,000)	(1,440,000)	(720,000)
Dividends paid to minority shareholders	(56,221)	(96,476)	(77,995)
Net cash used in financing activities	(2,398,981)	(3,094,218)	(794,196)
Net decrease in cash and cash equivalents	(149,876)	(339,882)	(450,122)
Cash and cash equivalents at beginning of year	1,840,351	1,690,500	1,347,237
Effect of foreign exchange rate changes	25	(3,381)	(2,465)
Cash and cash equivalents at end of year	1,690,500	1,347,237	894,650

See accompanying notes to consolidated financial statements.

SINOPEC SHANGHAI PETROCHEMICAL COMPANY LIMITED
AND SUBSIDIARIES

Notes to the Consolidated Statements of Cash Flows
For the years ended December 31, 2004, 2005 and 2006
(Amounts in thousands)

(a) Reconciliation of income before income tax and minority interests to cash generated from operations

	Years ended December 31,		
	2004	2005	2006
	Renminbi	Renminbi	Renminbi
Income before income tax	4,696,229	2,287,594	964,200
Interest income	(42,830)	(39,631)	(56,827)
Income from other unlisted investments	(62,800)	(101,350)	(97,179)
Share of losses/(profits) of associates and jointly controlled entities	36,915	60,968	(576,682)
Interest expense	325,033	276,174	303,386
Depreciation for property, plant and equipment	1,793,084	1,692,213	1,810,990
Depreciation for investment property	1,036	12,847	12,678
Impairment losses for property, plant and equipment	34,345	—	50,000
Amortization of lease prepayments	21,191	13,441	29,400
Amortization of goodwill	13,448	—	—
Unrealized exchange loss/(gain)	77	(53,174)	(78,841)
Loss/(gain) on disposal of property, plant and equipment	9,544	(15,298)	(19,569)
Increase in inventories	(223,490)	(387,229)	(48,278)
(Increase)/decrease in debtors, bills receivable and deposits	(514,956)	1,170,872	(585,256)
(Decrease)/increase in creditors, other creditors and bills payable	(389,221)	(33,850)	345,628
Decrease in balances with related companies	(105,990)	(207,470)	(1,870)
Cash generated from operations	5,591,615	4,676,107	2,051,780
Interest paid	(346,696)	(301,537)	(344,064)
Income tax paid	(673,214)	(430,992)	(63,386)
Income tax refund	18,006	—	52,285
Net cash generated from operating activities	<u>4,589,711</u>	<u>3,943,578</u>	<u>1,696,615</u>

See accompanying notes to consolidated financial statements.

SINOPEC SHANGHAI PETROCHEMICAL COMPANY LIMITED
AND SUBSIDIARIES
Consolidated Statements of Equity
For the years ended December 31, 2004, 2005 and 2006
(Amounts in thousands)

	Note	Share capital Renminbi	Share premium Renminbi	Reserves Renminbi	Retained earnings Renminbi	Minority interests Renminbi	Total equity Renminbi
Balances at January 1, 2004		7,200,000	2,420,841	3,257,418	2,143,627	341,240	15,363,126
Net income		—	—	—	3,971,103	88,065	4,059,168
Appropriation		—	—	794,254	(794,254)	—	—
Dividends approved in respect of previous year	12	—	—	—	(576,000)	—	(576,000)
Dividends paid to minority shareholders		—	—	—	—	(56,221)	(56,221)
Balances at December 31, 2004		7,200,000	2,420,841	4,051,672	4,744,476	373,084	18,790,073
Derecognition of negative goodwill		—	—	—	2,549	—	2,549
Balances at January 1, 2005(adjusted)		7,200,000	2,420,841	4,051,672	4,747,025	373,084	18,792,622
Net income		—	—	—	1,850,449	70,845	1,921,294
Appropriation	24	—	—	340,926	(340,926)	—	—
Dividends approved in respect of previous year	12	—	—	—	(1,440,000)	—	(1,440,000)
Dividends paid to minority shareholders		—	—	—	—	(96,476)	(96,476)
Balances at December 31, 2005		7,200,000	2,420,841	4,392,598	4,816,548	347,453	19,177,440
Balances at January 1, 2006		7,200,000	2,420,841	4,392,598	4,816,548	347,453	19,177,440
Net income		—	—	—	844,407	66,555	910,962
Appropriation	24	—	—	73,685	(73,685)	—	—
Changes in fair value of available-for-sale equity securities	24	—	—	21,949	—	—	21,949
Dividends approved in respect of previous year	12	—	—	—	(720,000)	—	(720,000)
Dividends paid to minority shareholders		—	—	—	—	(77,995)	(77,995)
Balances at December 31, 2006		<u>7,200,000</u>	<u>2,420,841</u>	<u>4,488,232</u>	<u>4,867,270</u>	<u>336,013</u>	<u>19,312,356</u>

See accompanying notes to consolidated financial statements.

SINOPEC SHANGHAI PETROCHEMICAL COMPANY LIMITED
AND SUBSIDIARIES
Notes to Consolidated Financial Statements
(All amounts in thousands, except per share data and except otherwise stated)

1. ORGANIZATION, PRINCIPAL ACTIVITIES AND BASIS OF PREPARATION

Sinopec Shanghai Petrochemical Company Limited (“the Company”), formerly Shanghai Petrochemical Company Limited, was established in the People’s Republic of China (“the PRC” or “the State”) on June 29, 1993 as a joint stock limited company to hold the assets and liabilities of the production divisions and certain other units of the Shanghai Petrochemical Complex (“SPC”). SPC was established in 1972 and owned and managed the production divisions as well as the related housing, stores, schools, hotels, transportation, hospitals and other municipal services in the community of Jinshanwei.

The Company’s former controlling shareholder, China Petrochemical Corporation (“CPC”) completed its reorganization on February 25, 2000 in which its interests in the Company were transferred to its subsidiary, China Petroleum & Chemical Corporation (“Sinopec Corp”). In connection with the reorganization, CPC transferred its 4,000,000,000 of the Company’s state owned legal shares, which represented 55.56 per cent of the issued share capital of the Company, to Sinopec Corp. On October 12, 2000, the Company changed its name to Sinopec Shanghai Petrochemical Company Limited.

The principal activity of the Company and its subsidiaries (the “Group”) is the processing of crude oil into petrochemical products for sale. The Group is one of the largest petrochemical enterprises in the PRC, with a highly integrated petrochemical complex which processes crude oil into a broad range of synthetic fibers, resins and plastics, intermediate petrochemicals and petroleum products. Substantially all of its products are sold in the PRC domestic market.

1. ORGANIZATION, PRINCIPAL ACTIVITIES AND BASIS OF PREPARATION

(continued)

At December 31, 2006, the following list contains the particulars of subsidiaries, all of which are limited companies established and operated in the PRC, which principally affected the results and assets of the Group.

Company	Registered Capital	Percentage of equity held by the Company %	Percentage of equity held by subsidiaries %	Principal activities
Shanghai Petrochemical Investment Development Company Limited	RMB 800,000	100	—	Investment management
China Jinshan Associated Associated Trading Corporation	RMB 25,000	67.33	—	Import and export of petrochemical products and equipment
Shanghai Golden Way Petrochemical Company Limited	US\$ 3,460	—	75	Production of vinyl acetate products
Shanghai Jinchang Engineering Plastics Company Limited	US\$ 4,750	—	50.38	Production of polypropylene compound products
Shanghai Golden Phillips Petrochemical Company Limited	US \$ 50,000	—	60	Production of polypropylene products
Zhejiang Jin Yong Acrylic Fibre Company Limited	RMB 250,000	75	—	Production of acrylic fiber products
Shanghai Petrochemical Enterprise Development Company Limited	RMB 455,000	100	—	Investment management
Shanghai Golden Conti Petrochemical Company Limited	RMB 545,776	—	100	Production of petrochemical products

None of the subsidiaries have issued any debt securities.

1. ORGANIZATION, PRINCIPAL ACTIVITIES AND BASIS OF PREPARATION

(continued)

The consolidated financial statements have been prepared in accordance with International Financial Reporting Standards (“IFRSs”) promulgated by the International Accounting Standards Board (“IASB”), and interpretations issued by the International Financial Reporting Interpretations Committee of the IASB. Information relating to the nature and effect of the significant differences between IFRSs and accounting principles generally accepted in the United States (“U.S. GAAP”) are set forth in Note 34.

The consolidated financial statements are prepared on the historical cost basis as modified by the revaluation of certain property, plant and equipment. The accounting policies have been consistently applied by the Group.

The preparation of financial statements in conformity with IFRSs requires management to make judgments, estimates and assumptions that affect the application of policies and reported amounts of assets and liabilities, income and expenses. The estimates and associated assumptions are based on historical experience and various other factors that are believed to be reasonable under the circumstances, the results of which form the basis of making the judgments about carrying values of assets and liabilities that are not readily apparent from other sources. Actual results may differ from these estimates.

The estimates and underlying assumptions are reviewed on an ongoing basis. Revisions to accounting estimates are recognized in the period in which the estimate is revised if the revision affects only that period, or in the period of the revision and future periods if the revision affects both current and future periods.

Key assumptions and estimation made by management in the application of IFRSs that have significant effect on the financial statements and have a significant risk of causing a material adjustment to the carrying amount of assets and liabilities in the next financial year are disclosed in Note 29.

2. PRINCIPAL ACCOUNTING POLICIES

(a) Basis of consolidation

(i) *Subsidiaries and minority interests*

The consolidated financial statements of the Group include the financial statements of the Company and all of its principal subsidiaries. Subsidiaries are entities controlled by the Group. Control exists when the Group has the power to govern the financial and operating policies of an entity so as to obtain benefits from its activities. In assessing control, potential voting rights that presently are exercisable are taken into account.

An investment in a subsidiary is consolidated into the consolidated financial statements from the date that control commences until the date that control ceases. Intra-group balances and transactions and any unrealized profits arising from intra-group transactions are eliminated in full in preparing the consolidated financial statements. Unrealized losses resulting from intra-group transactions are eliminated in the same way as unrealized gains but only to the extent that there is no evidence of impairment.

Minority interests represent the portion of the net assets of subsidiaries attributable to equity interests that are not owned by the Company, whether directly or indirectly through subsidiaries, and in respect of which the Group has not agreed any additional terms with the holders of those interests which would result in the group as a whole having a contractual obligation in respect of those interests that meets the definition of a financial liability. Minority interests are presented in the consolidated balance sheet within equity, separately from equity attributable to the equity shareholders of the Company. Minority interests in the results of the Group are presented on the face of the consolidated income statement as an allocation of the total profit or loss for the year between minority interests and the equity shareholders of the Company.

2. PRINCIPAL ACCOUNTING POLICIES *(continued)*

(a) Basis of consolidation (continued)

(ii) Associates and jointly controlled entities

An associate is an entity in which the Group or the Company has significant influence, but not control or joint control, over its management, including participation in the financial and operating policy decisions.

A jointly controlled entity is an entity which operates under a contractual arrangement between the Group or the Company and one or more of the other parties share joint control over the economic activity of the entity.

An investment in an associate or a jointly controlled entity is accounted for in the consolidated financial statements under the equity method and is initially recorded at cost and adjusted thereafter for the post acquisition change in the Group's share of the associate's or the jointly controlled entity's net assets.

When the Group's share of losses exceeds its interest in an associate or a jointly controlled entity, the Group's interest is reduced to nil and recognition of further losses is discontinued except to the extent that the Group has incurred legal or constructive obligations or made payments on behalf of the associate or the jointly controlled entity.

Unrealized profits and losses resulting from transactions between the Group and its associates and jointly controlled entities are eliminated to the extent of the Group's interest in the associate or jointly controlled entity, except where unrealized losses provide evidence of an impairment of the assets transferred, in which case they are recognized immediately in the profit or loss.

2. PRINCIPAL ACCOUNTING POLICIES *(continued)*

(b) Goodwill

Goodwill represents the excess of the cost of a business combination or an investment in an associate or a jointly controlled entity over the Group's interest in the net fair value of the acquiree's identifiable assets, liabilities and contingent liabilities.

Goodwill is stated at cost less any accumulated impairment losses. Goodwill is allocated to cash-generating units and is tested annually for impairment (see Note 2(s)). In respect of associates and jointly controlled entities, the carrying amount of goodwill is included in the carrying amount of the interest in associate or jointly controlled entities.

Any excess of the Group's interest in the net fair value of the acquiree's identifiable assets, liabilities and contingent liabilities over the cost of a business combination or an investment in an associate or a jointly controlled entity is recognized immediately in profit or loss.

(c) Investments

Investments in available-for-sale equity securities are carried at fair value with any change in fair value, other than impairment losses (see note 2 (s)), recognized directly in equity.

When these investments are derecognized or impaired, the cumulative gain or loss previously recognized directly in equity is recognized in the income statement. Investments in equity securities, that do not have a quoted market price in an active market and whose fair value cannot be reliably measured are recognized in the balance sheet at cost less impairment losses (see note 2(s)).

(d) Property, plant and equipment

Property, plant and equipment are stated in the balance sheet at cost or valuation (see Note 16) less accumulated depreciation and impairment losses (see Note 2(s)). Revaluations are performed with sufficient regularity to ensure that the carrying amount of these assets does not differ materially from that which would be determined using fair value at balance sheet date.

The cost of self-constructed assets includes the cost of materials, direct labour, the initial estimate, where relevant, of the costs of dismantling and removing the items and restoring the site on which they are located, and an appropriate proportion of production overheads and borrowing costs.

2. PRINCIPAL ACCOUNTING POLICIES *(continued)*

(d) Property, plant and equipment *(continued)*

Depreciation is provided to write off the costs /revalued amount of property, plant and equipment over their estimated useful lives on a straight-line basis, after taking into account their estimated residual values, as follows:

Buildings	15 to 40 years
Plant, machinery, equipment and others	5 to 26 years

Where parts of an item of property, plant and equipment have different useful lives the cost or valuation of the item is allocated on a reasonable basis between the parts and each part is depreciated separately. Both the useful life of an asset and its residual value are reviewed annually.

Gains or losses arising from the retirement or disposal of items of property, plant and equipment are determined as the difference between the net disposal proceeds and the carrying amount of the items and are recognized in the income statement on the date of retirement or disposal.

(e) Investment property

Investment properties are properties which are owned or held under a leasehold interest either to earn rental income or for capital appreciation or for both.

Investment properties are stated in the balance sheet at cost less accumulated depreciation. Depreciation is provided over their estimated useful lives on a straight-line basis, after taking into account their estimated residual values. Estimated useful life of investment property is 40 years.

(f) Lease prepayments and other assets

Lease prepayments and other assets represent land use rights paid to the PRC's Land Bureau and catalysts used in production. They are carried at cost less accumulated amortization and impairment losses (see Note 2(s)). Amortization is provided to write off the cost of lease prepayment and other assets on a straight-line basis over the respective periods of the rights and the estimated useful lives of the catalysts.

2. PRINCIPAL ACCOUNTING POLICIES *(continued)*

(g) Construction in progress

Construction in progress represents buildings, various plant and equipment under construction and pending installation, and is stated at cost less the government grants that compensate the Company for the cost of construction and impairment losses (see Note 2(s)). Cost comprises direct costs of construction as well as interest charges, and foreign exchange differences on related borrowed funds to the extent that they are regarded as an adjustment to interest charges, during the period of construction.

Construction in progress is transferred to property, plant and equipment when the asset is substantially ready for its intended use.

No depreciation is provided in respect of construction in progress.

(h) Inventories

Inventories, other than spare parts and consumables, are carried at the lower of cost and net realizable value. Cost is calculated using the weighted average cost formula and comprise all costs of purchase, costs of conversion and other costs incurred in bringing the inventories to their present location and condition. In the case of work in progress and finished goods, cost includes direct labour and an appropriate proportion of production overheads. Net realizable value is the estimated selling price in the ordinary course of business less the estimated costs of completion and the estimated costs necessary to make the sale.

When inventories are sold, the carrying amount of the inventories is recognized as an expense in the period in which the related revenue is recognized. The amount of any write-down of inventories to net realizable value and all losses of inventories are recognized as an expense in the period the write-down or loss occurs. The amount of any reversal of any write-down of inventories, arising from an increase in net realizable value, is recognized as a reduction in the amount of inventories recognized as an expense in the period in which the reversal occurs.

Spare parts and consumables are stated at cost less any provision for obsolescence.

2. PRINCIPAL ACCOUNTING POLICIES *(continued)*

(i) Trade and other receivables

Trade and other receivables are initially recognized at fair value and thereafter stated at amortized cost less impairment losses for bad and doubtful debts (see Note 2(s)), except where the receivables are interest-free loans made to related parties without any fixed repayment terms or the effect of discounting would be immaterial. In such cases, the receivables are stated at cost less impairment losses for bad and doubtful debts (see Note 2(s)).

(j) Trade and other payables

Trade and other payables are initially recognized at fair value and thereafter stated at amortized cost unless the effect of discounting would be immaterial, in which case they are stated at cost.

(k) Cash and cash equivalents

Cash and cash equivalents comprise cash at bank and on hand and time deposits with financial institutions with an initial term of less than three months when purchased. Cash equivalents are stated at cost, which approximates fair value.

(l) Translation of foreign currencies

Foreign currency transactions during the year are translated into Renminbi at the applicable exchange rates ruling at the transaction dates.

Monetary assets and liabilities denominated in foreign currencies are translated into Renminbi at rates quoted by the People's Bank of China at the balance sheet date. Non-monetary assets and liabilities denominated in foreign currencies, which are stated at historical cost, are translated into Renminbi at the foreign exchange rate ruling at the date of the transaction.

Foreign currency translation differences relating to funds borrowed to finance the construction of property, plant and equipment to the extent that they are regarded as an adjustment to interest costs are capitalized during the construction period. All other exchange gains and losses are dealt with in the income statement.

2. PRINCIPAL ACCOUNTING POLICIES *(continued)*

(m) Revenue recognition

Revenue from the sale of goods is recognized in the income statement when the significant risks and rewards of ownership have been transferred to the buyer. Revenue excludes value added tax and is after deduction of any trade discounts and returns. No revenue is recognized if there are significant uncertainties regarding recovery of the consideration due to the possible return of goods, or when the amount of revenue and the costs incurred or to be incurred in respect of the transaction cannot be measured reliably.

Revenue from services rendered is recognized in the income statement upon performance of the services.

Dividend income is recognized in the income statement on the date the entity's right to receive payments is established.

Rental income from investment property is recognized in the income statement on a straight-line basis over the term of the lease.

(n) Government grants

Government grants are recognized in the balance sheet initially when there is reasonable assurance that they will be received and that the Group will comply with the conditions attaching to them. Grants that compensate the Group for expenses incurred are recognized as revenue in profit or loss on a systematic basis in the same periods in which the expenses are incurred. Grants that compensate the Group for the cost of an asset are deducted in arriving at the carrying amount of the asset and consequently are recognized in profit and loss over the useful life of the asset.

(o) Net financing costs

Net financing costs comprise interest payable on borrowings calculated using the effective interest rate method, interest income on bank deposits, foreign exchange gains and losses and bank charges.

Interest income from bank deposits is recognized in the income statement as it accrues using the effective interest method.

All interest and other costs incurred in connection with borrowings are expensed as incurred as part of net financing costs, except to the extent that they are capitalized as being directly attributable to the acquisition or construction of an asset which necessarily takes a substantial period of time to get ready for its intended use or sale.

2. PRINCIPAL ACCOUNTING POLICIES *(continued)*

(p) Repairs and maintenance expenses

Repairs and maintenance expenses are charged to the income statement as and when they are incurred.

(q) Research and development costs

Research and development costs comprise all costs that are directly attributable to research and development activities or that can be allocated on a reasonable basis to such activities. Because of the nature of the Group's research and development activities, no development costs satisfy the criteria for the recognition of such costs as an asset. Both research and development costs are therefore recognized as expenses in the period in which they are incurred.

(r) Retirement benefits

The contributions payable under the Group's retirement plans are charged to the income statement on an accrual basis according to the contribution determined by the plans. Further information is set out in Note 26.

(s) Impairment loss

(i) Impairment of trade accounts receivable, other receivables and investments in equity securities other than investments in associates and jointly controlled entities are accounted as follows:

Trade accounts receivable, other receivables and investments in equity securities other than investments in associates and jointly controlled entities are reviewed at each balance sheet date to determine whether there is objective evidence of impairment. If any such evidence exists, an impairment loss is determined and recognized. The impairment loss is measured as the difference between the asset's carrying amount and the estimated future cash flows, discounted at the current market rate of return for a similar asset where the effect of discounting is material. Impairment losses for trade accounts and other receivables are reversed if in a subsequent period the amount of the impairment loss decreases. Impairment losses for investments in equity securities are not reversed.

2. PRINCIPAL ACCOUNTING POLICIES *(continued)*

(s) Impairment loss *(continued)*

(ii) Impairment of other long-lived assets is accounted as follows:

The carrying amounts of other long-lived assets, including property, plant and equipment, construction in progress, lease prepayment, other assets and investments in associates and jointly controlled entities, are reviewed periodically in order to assess whether the recoverable amounts have declined below the carrying amounts. These assets are tested for impairment whenever events or changes in circumstances indicate that their recorded carrying amounts may not be recoverable. When such a decline has occurred, the carrying amount is reduced to the recoverable amount. For goodwill, the recoverable amount is estimated at each balance sheet date.

The recoverable amount is the greater of the fair value less costs to sell and the value in use. In determining the value in use, expected future cash flows generated by the asset are discounted to their present value using a pre-tax discount rate that reflects current market assessments of time value of money and the risks specific to the asset. Where an asset does not generate cash inflows largely independent of those from other assets, the recoverable amount is determined for the smallest group of assets that generates cash inflows independently (i.e. a cash-generating unit).

The amount of the reduction is recognized as an expense in the income statement unless the asset is carried at revalued amount for which an impairment loss is recognized directly against any related revaluation reserve to the extent that the impairment loss does not exceed the amount held in the revaluation reserve for that same asset. Impairment losses recognized in respect of cash-generating units are allocated first to reduce the carrying amount of any goodwill allocated to the cash-generating unit and then, to reduce the carrying amount of the other assets in the unit on a pro rata basis, except that the carrying value of an asset will not be reduced below its individual fair value less costs to sell, or value in use, if determinable.

The Group assesses at each balance sheet date whether there is any indication that an impairment loss recognized for an asset, except in the case of goodwill, in prior years may no longer exist. An impairment loss is reversed if there has been a favourable change in the estimates used to determine the recoverable amount. A subsequent increase in the recoverable amount of an asset, when the circumstances and events that led to the write-down or write-off cease to exist, is recognized as income unless the asset is carried at revalued amount. Reversal of an impairment loss on a revalued asset is credited to the revaluation reserve except for impairment loss which was previously recognized as an expense in the income statement; a reversal of such impairment loss is recognized as an income. The reversal is reduced by the amount that would have been recognized as depreciation had the write-down or write-off not occurred. An impairment loss in respect of goodwill is not reversed.

2. PRINCIPAL ACCOUNTING POLICIES *(continued)*

(t) Dividends

Dividends are recognized as a liability in the period in which they are declared.

(u) Income tax

Income tax on the income statement for the year comprises current and deferred tax.

Current tax is the expected tax payable on the taxable income for the year, using tax rates enacted or substantially enacted at the balance sheet date, and any adjustment to tax payable in respect of previous years.

Deferred tax is provided using the balance sheet liability method, providing for temporary differences between the carrying amounts of assets and liabilities for financial reporting purposes and the amounts used for taxation purposes, except differences relating to goodwill not deductible for tax purposes and the initial recognition of assets or liabilities which affect neither accounting nor taxable income. The amount of deferred tax provided is based on the expected manner of realization or settlement of the carrying amount of assets and liabilities, using tax rates enacted or substantially enacted at the balance sheet date. The effect on deferred tax of any changes in tax rates is charged to the income statement.

A deferred tax asset is recognized only to the extent that it is probable that future taxable income will be available against which the assets can be utilized. Deferred tax assets are reduced to the extent that it is no longer probable that the related tax benefit will be realized.

(v) Provisions and contingent liabilities

Provisions are recognized for liabilities of uncertain timing or amount when the Group has a legal or constructive obligation arising as a result of a past event, it is probable that an outflow of economic benefits will be required to settle the obligation and a reliable estimate can be made.

Where it is not probable that an outflow of economic benefits will be required, or the amount cannot be estimated reliably, the obligation is disclosed as a contingent liability, unless the probability of outflow of economic benefits is remote. Possible obligations, whose existence will only be confirmed by the occurrence or non-occurrence of one or more future events are also disclosed as contingent liabilities unless the probability of outflow of economic benefits is remote.

2. PRINCIPAL ACCOUNTING POLICIES *(continued)*

(w) Related parties

Parties are considered to be related to the Group if the Group has the ability, directly or indirectly, to control or jointly control the party or exercise significant influence over the party in making financial and operating decisions, or vice versa, or where the Group and the party are subject to common control or common significant influence. Related parties may be individuals (being members of key management personnel, significant shareholders and/or their close family members) or other entities and include entities which are under the significant influence of related parties of the Group where those parties are individuals, and post-employment benefit plans which are for the benefit of employees of the Group or of any entity that is a related party of the Group.

(x) Segment reporting

A segment is a distinguishable component of the Group that is engaged in providing products or services and is subject to risks and rewards that are different from those of other segments.

3. SALES

The Group's principal activity is the processing of crude oil into petrochemical products for sale and substantially all of its products are sold in the PRC domestic markets.

Sales represents the sales value of goods sold to customers, net of value added tax and is after deduction of any sales discounts and returns.

4. OTHER INCOME

The Group received a cash government grant from the Ministry of Finance of the PRC of RMB 282,142 (2005: RMB 632,820) as a compensation of loss incurred due to the distortion of the correlation of domestic refined petroleum product prices and the crude oil prices during the year ended December 31, 2006. There are no unfilled conditions and other contingencies attached to the receipt or usage of this government grant. There is no assurance that the Group will continue to receive such grant in the future.

5. COST OF SALES

Cost of sales represents:

	Years ended December 31,		
	2004	2005	2006
Costs of raw materials			
-crude oil	19,461,243	29,576,407	33,307,637
-other ancillary materials	6,091,649	6,953,588	7,901,778
Depreciation	1,793,084	1,692,213	1,810,990
Repairs and maintenance	920,490	896,022	874,461
Research and development	74,663	54,451	51,610
Employer' s pension costs			
-municipal retirement scheme costs	167,640	165,046	207,071
-supplementary retirement scheme costs	42,379	56,917	61,692
Staff costs	1,172,442	1,168,461	1,210,266
Amortization of lease prepayments	21,191	13,441	29,400
Others	3,478,823	2,311,196	3,727,327
	<u>33,223,604</u>	<u>42,887,742</u>	<u>49,182,232</u>

6. OTHER OPERATING INCOME

Other operating income represents:

	Years ended December 31,		
	2004	2005	2006
Income from rendering of services	130,298	57,421	35,068
Gain on disposal of property, plant and equipment	58,913	42,233	83,386
Rental income from investment property	—	18,681	42,643
Income from other unlisted investments	62,800	101,350	97,179
Amortization of deferred income	12,367	11,518	23,033
Others	12,627	7,408	16,085
	<u>277,005</u>	<u>238,611</u>	<u>297,394</u>

7. OTHER OPERATING EXPENSES

Other operating expenses represent:

	Years ended December 31,		
	2004	2005	2006
Loss on disposal of property, plant and equipment	68,457	26,935	63,817
Employee reduction expenses (Note 8)	112,526	109,410	83,603
Amortization of goodwill (Note 21)	13,448	—	—
Impairment of property, plant and equipment (Note (i) and 16)	34,345	—	50,000
Donations	9,992	8,079	380
Other	45,396	57,070	42,730
	<u>284,164</u>	<u>201,494</u>	<u>240,530</u>

- (i) Impairment loss recognized on property, plant and equipment of synthetic fibres segment was RMB 50,000 (2005: nil; 2004: RMB 34,345) for the year ended December 31, 2006. The impairment loss relates to certain polypropylene fibre and compound fibre facilities that have ceased production during the year. In measuring the amounts of impairment charges, the carrying amounts of these assets were compared to the present value of the expected future cash flows of the assets, as well as information about their fair values less costs to sell.

8. EMPLOYEE REDUCTION EXPENSES

In accordance with the Group's voluntary employee reduction plan, the Group recorded employee reduction expenses of RMB 83,603 during the year ended December 31, 2006 (2005: RMB 109,410; 2004: RMB 112,526) in respect of the voluntary resignation of approximately 1,280 employees (1,645 employees in 2005 and 1,500 employees in 2004).

9. NET FINANCING COSTS

Net financing costs represent:

	Years ended December 31,		
	2004	2005	2006
Interest expenses, net	325,033	276,174	303,386
Interest income	(42,830)	(39,631)	(56,827)
Foreign exchange losses/(gain), net	9,805	(57,145)	(81,170)
	<u>292,008</u>	<u>179,398</u>	<u>165,389</u>

Interest costs capitalized as a component of the cost of construction in progress amounted to RMB 23,801, RMB 33,183 and RMB 64,330 in 2004, 2005 and 2006 respectively. Interest costs have been capitalized at a rate of 5.18%—5.85% per annum (2005: 2.98%-5.56%; 2004: 2.98%-5.58%) for construction in progress.

10. TAXATION

(a) Taxation in the consolidated income statement represents:

	Years ended December 31,		
	2004	2005	2006
Provision for PRC income tax for the year	725,897	340,532	71,183
Over-provision in respect of prior years	—	—	(6,911)
Deferred taxation	(13,257)	25,768	(11,034)
Tax refund	(75,579)	—	—
	<u>637,061</u>	<u>366,300</u>	<u>53,238</u>

A reconciliation of the income tax calculated at the applicable tax rate with income tax expense is as follows:

	Years ended December 31,		
	2004	2005	2006
Income before income tax	4,696,229	2,287,594	964,200
Expected tax at applicable tax rate of 15%	704,435	343,139	144,630
Non-deductible expenses	864	7,679	7,361
Non-taxable earnings	(7,589)	(4,438)	(5,414)
Over-provision in respect of prior years	—	—	(6,911)
Tax effect of share of (profit)/losses recognized under the equity method	5,537	9,145	(86,503)
Tax effect of unused tax losses not recognized for deferred tax	3,487	7,090	9,688
Income tax refund	(75,579)	—	—
Differential tax rate on subsidiaries income	5,906	3,685	(9,613)
Income tax expense	<u>637,061</u>	<u>366,300</u>	<u>53,238</u>

The charge for income tax is calculated at the rate of 15% (2005: 15%; 2004: 15%) on the estimated assessable income of the year determined in accordance with relevant income tax rules and regulations. The Group did not carry out business overseas and therefore does not incur overseas income tax. Up to the date of approval of these financial statements, the Company has not received notice from the Ministry of Finance that the 15% tax rate will be revoked in 2006 or in the future. It is possible that the Company's tax rate will increase in the future. A non-adjusting post balance sheet event in respect of the potential change in the Company's applicable tax rate is disclosed in Note 32.

10. TAXATION (continued)

(b) Deferred taxation:

- (i) Deferred tax assets and deferred tax liabilities are attributable to the items detailed in the tables below:

	Assets		Liabilities		Net balance	
	December 31,		December 31,		December 31,	
	2005	2006	2005	2006	2005	2006
Current						
Provisions	11,396	12,141	—	—	11,396	12,141
Non-current						
Provisions for impairment losses	8,842	16,342	—	—	8,842	16,342
Lease prepayments	19,403	18,880	—	—	19,403	18,880
Capitalization of borrowing costs	—	—	(16,492)	(20,799)	(16,492)	(20,799)
Others	—	7,619	—	(3,873)	—	3,746
Deferred tax assets/ (liabilities)	<u>39,641</u>	<u>54,982</u>	<u>(16,492)</u>	<u>(24,672)</u>	<u>23,149</u>	<u>30,310</u>

- (ii) Movement in deferred tax assets and liabilities are as follows:

	Balance at January 1, 2004	Recognized in consolidated statements of income	Balance at December 31, 2004
Current			
Provisions	21,163	11,437	32,600
Non-current			
Provision for impairment losses	3,690	5,152	8,842
Lease prepayments	20,453	(525)	19,928
Capitalization of borrowing costs	(9,646)	(2,807)	(12,453)
Net deferred tax assets	<u>35,660</u>	<u>13,257</u>	<u>48,917</u>

	Balance at January 1, 2005	Recognized in consolidated statements of income	Balance at December 31, 2005
Current			
Provisions	32,600	(21,204)	11,396
Non-current			
Provision for impairment losses	8,842	—	8,842
Lease prepayments	19,928	(525)	19,403
Capitalization of borrowing costs	(12,453)	(4,039)	(16,492)
Net deferred tax assets	<u>48,917</u>	<u>(25,768)</u>	<u>23,149</u>

10. TAXATION (continued)

(b) Deferred taxation: (continued)

(ii) Movement in deferred tax assets and liabilities are as follows: (continued)

	Balance at January 1, 2006	Recognized in consolidated statements of income	Recognized in reserve	Balance at December 31, 2006
Current				
Provisions	11,396	745	—	12,141
Non-current				
Provision for impairment losses	8,842	7,500	—	16,342
Lease prepayments	19,403	(523)	—	18,880
Capitalization of borrowing costs	(16,492)	(4,307)	—	(20,799)
Others	—	7,619	(3,873)	3,746
Net deferred tax assets	<u>23,149</u>	<u>11,034</u>	<u>(3,873)</u>	<u>30,310</u>

11. BASIC EARNINGS PER SHARE

The calculation of basic earnings per share is based on the profit attributable to shareholders of RMB 844,407 (2005: RMB 1,850,449, 2004: RMB 3,971,103) and 7,200,000,000 (2005: 7,200,000,000; 2004: 7,200,000,000) shares in issue during the year.

The amount of diluted earnings per share is not presented as there were no dilutive potential ordinary shares in existence for each of the years in the three-year period ended December 31, 2006.

12. DIVIDEND

(a) Dividends attributable to the year:

	Years ended December 31,		
	2004	2005	2006
Final dividend proposed after the balance sheet date of RMB 0.04 per share (2005: RMB 0.10 per share, 2004: RMB 0.20 per share)	<u>1,440,000</u>	<u>720,000</u>	<u>288,000</u>

Pursuant to a resolution passed at the directors' meeting on March 29, 2007, a final dividend of RMB 0.04 per share totaling RMB 288,000 (2005: RMB 720,000; 2004: RMB 1,440,000) was proposed for shareholders' approval at the Annual General Meeting. The final dividend proposed after the balance sheet date has not been recognized as a liability at the balance sheet date.

12. DIVIDEND (continued)

(b) Dividends attributable to the previous financial year, approved and paid during the year:

	Years ended December 31,		
	2004	2005	2006
Final dividend in respect of the previous financial year, approved and paid during the year, of RMB 0.10 per share (2005: RMB 0.20; 2004: RMB 0.08)	<u>576,000</u>	<u>1,440,000</u>	<u>720,000</u>

13. INVENTORIES

Inventories in the balance sheet comprise:

	December 31,	
	2005	2006
Raw materials	1,050,904	873,130
Work in progress	1,592,298	1,661,487
Finished goods	895,951	1,014,225
Spare parts and consumables	<u>575,825</u>	<u>614,414</u>
	<u>4,114,978</u>	<u>4,163,256</u>

At December 31, 2006, the Group had inventories carried at net realizable value with carrying amount of RMB 208,157. (2005: RMB 187,129).

Allowance for diminution in value of inventories, primarily related to spare parts and consumables, is analyzed as follows:

At January 1, 2004	68,511
Provision for the year	4,450
Write-off	<u>(16,291)</u>
At December 31, 2004	56,670
Provision for the year	1,636
Write-off	<u>(8,236)</u>
At December 31, 2005	50,070
Provision for the year	33,407
Write-off	<u>(42,122)</u>
At December 31, 2006	<u>41,355</u>

14. TRADE DEBTORS

Trade debtors comprise:

	December 31,	
	2005	2006
Trade debtors	278,011	389,601
Less: Impairment losses for bad and doubtful debts	(25,845)	(30,911)
	<u>252,166</u>	<u>358,690</u>

Impairment losses for bad and doubtful debts are analyzed as follows:

At January 1, 2004	39,811
Provision for the year	22,814
Written-off	(17,343)
At December 31, 2004	45,282
Provision for the year	13,683
Written-off	(33,120)
At December 31, 2005	25,845
Provision for the year	8,513
Written-off	(3,447)
At December 31, 2006	<u>30,911</u>

15. OTHER DEBTORS AND PREPAYMENTS

Other debtors and prepayments comprise:

	December 31,	
	2005	2006
Purchase deposits	134,577	68,661
Prepayments in connection with construction work and equipment purchases	150,174	2,884
Sundry debtors	<u>170,292</u>	<u>167,569</u>
	<u>455,043</u>	<u>239,114</u>

16. PROPERTY, PLANT AND EQUIPMENT

Property, plant and equipment comprise:

	<u>Buildings</u>	<u>Plant and other fixed assets</u>	<u>Total</u>
<i>Cost or valuation:</i>			
At January 1, 2005	5,324,173	25,863,939	31,188,112
Additions	—	164,816	164,816
Transferred from construction in progress (Note 18)	215,194	808,233	1,023,427
Disposals	(37,480)	(134,456)	(171,936)
At December 31, 2005	<u>5,501,887</u>	<u>26,702,532</u>	<u>32,204,419</u>
At January 1, 2006	5,501,887	26,702,532	32,204,419
Additions	41,376	147,671	189,047
Transferred from construction in progress (Note 18)	128,200	502,704	630,904
Disposals	(47,923)	(812,917)	(860,840)
At December 31, 2006	<u>5,623,540</u>	<u>26,539,990</u>	<u>32,163,530</u>
<i>Accumulated depreciation and impairment losses:</i>			
At January 1, 2005	2,804,251	13,177,536	15,981,787
Charge for the year	174,911	1,517,302	1,692,213
Written back on disposals	(25,653)	(95,095)	(120,748)
At December 31, 2005	<u>2,953,509</u>	<u>14,599,743</u>	<u>17,553,252</u>
At January 1, 2006	2,953,509	14,599,743	17,553,252
Charge for the year	164,172	1,646,818	1,810,990
Impairment loss	—	50,000	50,000
Written back on disposals	(35,814)	(574,760)	(610,574)
At December 31, 2006	<u>3,081,867</u>	<u>15,721,801</u>	<u>18,803,668</u>
<i>Net book value:</i>			
At December 31, 2006	<u>2,541,673</u>	<u>10,818,189</u>	<u>13,359,862</u>
At December 31, 2005	<u>2,548,378</u>	<u>12,102,789</u>	<u>14,651,167</u>

16. PROPERTY, PLANT AND EQUIPMENT *(continued)*

All of the Group's buildings are located in the PRC (including Hong Kong).

Buildings in Hong Kong with a net book value of RMB 34,129 (2005: RMB 35,314) were held under medium-term leases.

The Company was established in the PRC on June 29, 1993 as a joint stock limited company as part of the restructuring of Shanghai Petrochemical Complex ("SPC"). On the same date, the principal business undertakings of SPC together with the relevant assets and liabilities were taken over by the Company. As required by the relevant PRC rules and regulations, a valuation of the assets and liabilities to be injected into the Company was carried out as at January 1, 1993 by the State-owned Assets Administration Bureau and the injected assets and liabilities were reflected in the financial statements on this basis.

In accordance with IAS 16, subsequent to this revaluation, which was based on depreciated replacement costs, property, plant and equipment are carried at revalued amount, being the fair value at the date of the revaluation less any subsequent accumulated depreciation and impairment losses. Revaluation is performed periodically to ensure that the carrying amount does not differ materially from that which would be determined using fair value at the balance sheet date. Based on a revaluation performed as of February 5, 2005, which was based on depreciated replacement costs, the carrying value of property, plant and equipment did not differ materially from their fair value.

17. INVESTMENT PROPERTY

	<u>2005</u>	<u>2006</u>
Cost:		
At January 1	512,343	528,465
Additions	16,122	—
At December 31	<u>528,465</u>	<u>528,465</u>
Accumulated depreciation:		
At January 1	1,036	13,883
Charge for the year	12,847	12,678
At December 31	<u>13,883</u>	<u>26,561</u>
Net book value:		
At December 31	<u>514,582</u>	<u>501,904</u>

Investment property represents certain floors of an office building rented out under the terms of operating leases.

The fair value of the investment property of the Group as at December 31, 2006 was estimated by the directors to be approximately RMB 622,098 by reference to market conditions (2005: RMB 596,598). The investment property has not been valued by an external independent valuer.

Rental income of RMB 42,643 was received by the Group during the year ended December 31, 2006 (2005: RMB 18,681).

18. CONSTRUCTION IN PROGRESS

Construction in progress comprises costs incurred on property, plant and equipment not yet commissioned. The movement of construction in progress is as follows:

	<u>2005</u>	<u>2006</u>
At January 1	807,477	787,376
Additions	1,003,326	1,851,975
Transferred to property, plant and equipment (Note 16)	<u>(1,023,427)</u>	<u>(630,904)</u>
At December 31	<u>787,376</u>	<u>2,008,447</u>

19. INTEREST IN ASSOCIATES AND JOINTLY CONTROLLED ENTITIES

	December 31,	
	2005	2006
Interest in associates	2,130,803	2,708,323
Interest in jointly controlled entities	—	79,472
	<u>2,130,803</u>	<u>2,787,795</u>

The above amount represents the share of net assets of the Company's interest in its associates and jointly controlled entities.

The particulars of these associates and jointly controlled entities, which are limited companies established and operating in the PRC, which principally affected the results or assets of the Group at December 31, 2006 are as follows:

Company	Registered Capital	Percentage of equity held by the Company %	Percentage of equity held by subsidiaries %	Principal activities
Shanghai Chemical Industry Park Development Company Limited	RMB2,372,439	38.26	—	Planning, development and operation of the Chemical Industry Park in Shanghai, PRC
Shanghai Secco Petrochemical Company Limited	US\$ 901,441	20	—	Manufacturing and distribution of chemical products
Shanghai Jinpu Plastics Packaging Material Company Limited	US\$ 20,204	—	50	Production of polypropylene film
Shanghai Jinsen Hydrocarbon Resins Company Limited	US\$ 23,395	—	40	Production of resins products
Shanghai Yamatake Automation Company Limited	US\$ 3,000	—	40	Service and maintenance of building automation systems and products
BOC-SPC Gases Company Limited	US\$ 32,000	50	—	Production and sales of industrial gases

19. INTEREST IN ASSOCIATES AND JOINTLY CONTROLLED ENTITIES (continued)

Summary financial information on associates, not adjusted for the percentage ownership held by the Group:

	<i>2005</i>	<i>2006</i>
	<i>RMB ' 000</i>	<i>RMB ' 000</i>
Total assets	25,919,334	29,206,140
Total liabilities	(16,304,925)	(16,392,029)
Revenues	13,189,878	22,477,236
(Loss)/profit for the year	(293,741)	2,747,085

20. INVESTMENTS

Investments comprise:

	December 31,	
	2005	2006
Investments in non-consolidated investees (unlisted)	326,515	274,864
Other unlisted investments	395,076	292,905
	721,591	567,769
Less provision for impairment losses	(56,228)	(38,838)
	<u>665,363</u>	<u>528,931</u>

Investments in non-consolidated investees represent the Company's interests in these investees which do not principally affect the results, assets or liabilities of the Group and, therefore, are not consolidated.

21. GOODWILL

Cost:	
At January 1, 2005, December 31, 2005 and December 31, 2006	22,415
Accumulated impairment losses:	
At January 1, 2005, December 31, 2005 and December 31, 2006	—
At December 31, 2005 and December 31, 2006	<u>22,415</u>

On August 16, 1996, the Company acquired the entire equity interest in Shanghai Jinyang Acrylic Fibre Plant (“Jinyang”) for a consideration of RMB 38,800 satisfied in cash. Goodwill of RMB 134,482 on acquisition has been recognized in the financial statements and was included in interests in subsidiaries.

Prior to January 1, 2005, goodwill not already recognized directly in reserves was amortized on a straight-line basis over ten years. With effect from January 1, 2005, the Company no longer amortizes goodwill. In accordance with transitional provisions set out in IFRS 3, the accumulated amortization of goodwill as at January 1, 2005 has been eliminated against the cost of goodwill as at that date. Such goodwill is tested annually for impairment.

22. DEBT

Short-term debts represent:

	December 31,	
	2005	2006
Short-term bank loans	2,523,537	1,853,692
Current portion of long-term bank loans	1,373,205	416,645
Corporate bonds	—	2,000,000
	3,896,742	4,270,337
Loans from a related company	30,000	—
	<u>3,926,742</u>	<u>4,270,337</u>

The Group’s short-term debts are used primarily to finance working capital needs. At December 31, 2006, no bank loans and borrowings were secured by the way of pledge of property, plant and equipment. (2005: RMB Nil). The Group’s weighted average short-term interest rates were 4.53% and 5.87% at December 31, 2005 and 2006, respectively.

22. DEBT (continued)

The Company issued 365-day unsecured corporate bonds of face value at RMB 2 billion to corporate investors in the PRC inter-bank debenture market on December 11 2006. The bonds were issued at 100% of face value, with an effective yield 3.83% per annum, and will mature on December 12, 2007.

The Group's long-term debts, which are for the addition of plant and equipment and working capital purposes, comprise:

	Interest rate at December 31, 2006	Interest type	December 31,	
			2005	2006
Arranged by Central Treasury of the Company:				
U.S. Dollar denominated:				
Due in 2007	5.70%	Floating	397,112	383,034
Payable semi-annually through 2008 (note (a))	1.80%	Fixed	41,123	23,710
Renminbi denominated:				
Due in 2006	5.18% - 5.56%	Fixed	1,340,000	—
Due in 2008	5.18% - 5.67%	Fixed	700,000	400,000
Due in 2009	5.18% - 5.67%	Fixed	—	450,000
Other loans due in 2015	Interest free	—	15,000	—
Arranged by subsidiaries:				
U.S. Dollar denominated:				
Payable annually through 2011	Interest free	—	17,431	14,055
Renminbi denominated:				
Payable due in 2007	5.85%	Fixed	116,500	8,500
Payable due in 2008	5.67%	Fixed	110,000	110,000
Payable annually through 2010	Interest free	—	102,500	82,000
Payable annually through 2011	Interest free	—	10,800	9,000
Total long-term bank loans outstanding			2,850,466	1,480,299
Less: Amounts due within one year			(1,373,205)	(416,645)
Amounts due after one year			<u>1,477,261</u>	<u>1,063,654</u>

Note (a) Guaranteed by China Petrochemical Corporation

22. DEBT (continued)

The aggregate maturities of long-term loans subsequent to December 31, 2006 are as follows:

2007	416,645
2008	558,821
2009	475,111
2010	25,111
2011	4,611
	<u>1,480,299</u>

Included in short-term and long-term debts are the following amounts denominated in currencies other than the functional currency of the entity to which they relate:

	December 31,	
	2005	2006
United States Dollars	<u>USD 340,154</u>	<u>USD 261,901</u>

23. SHARE CAPITAL

Share capital represents:

	December 31,	
	2005	2006
Registered, issued and paid up capital:		
4,870,000,000 A shares of RMB 1.00 each	4,870,000	4,870,000
2,330,000,000 H shares of RMB 1.00 each	<u>2,330,000</u>	<u>2,330,000</u>
	<u>7,200,000</u>	<u>7,200,000</u>

All the A and H shares rank pari passu in all respects.

24. SHARE PREMIUM AND RESERVES

Movements on reserves comprise:

	<u>2005</u>	<u>2006</u>
	<i>Note c</i>	
Share premium (Note a)		
Balance at January 1 and December 31	2,420,841	2,420,841
Statutory surplus reserve (Note b)		
Balance at January 1	1,457,791	3,174,419
Appropriation	170,463	73,685
Statutory public welfare fund transfer to statutory surplus reserve (Note c)	1,546,165	—
Balance at December 31	3,174,419	3,248,104
Statutory public welfare fund (Note c)		
Balance at January 1	1,375,702	—
Appropriation	170,463	—
Statutory public welfare fund transfer to statutory surplus reserve (Note c)	(1,546,165)	—
Balance at December 31	—	—
General surplus reserve (Note d)		
Balance at January 1 and December 31	82,089	82,089
Capital reserve fund (Note e)		
Balance at January 1 and December 31	4,180	4,180
Discretionary surplus reserve (Note f)		
Balance at January 1 and December 31	1,280,514	1,280,514
Excess over share capital (Note g)		
Balance at January 1 and December 31	(148,604)	(148,604)
Fair value reserve		
At 31 December (Note h)	—	21,949
Retained profits (Note i)		
Balance at January 1 and December 31	4,816,548	4,867,270
	<u>11,629,987</u>	<u>11,776,343</u>

24. SHARE PREMIUM AND RESERVES *(continued)*

Note a

The application of the share premium account is governed by Sections 178 and 179 of the PRC Company Law.

Note b

According to the Company's Articles of Association, the Company is required to transfer 10% of its profit after taxation, as determined under PRC Accounting Rules and Regulations, to a statutory surplus reserve until the reserve balance reaches 50% of the registered capital. The transfer to this reserve is made before distribution of a dividend to shareholders.

The statutory surplus reserve can be used to make good previous years' losses, if any, and may be converted into share capital by the issue of new shares to shareholders in proportion to their existing shareholdings or by increasing the par value of the shares currently held by them, provided that the balance after such issue is not less than 25% of the registered capital.

Note c

Pursuant to the notice "Cai Qi [2006] No. 67" issued by the Ministry of the Finance of the PRC and a resolution of the Shareholders' meeting on 15 June 2006, the Company is no longer required to make profit appropriation to the statutory public welfare fund commencing from January 1, 2006. The balance of this fund as at December 31, 2005 was transferred to the statutory surplus reserve.

Note d

When the statutory public welfare fund is utilized, an amount equal to the lower of cost of the assets and the balance of the statutory public welfare fund is transferred from the statutory public welfare fund to the general surplus reserve. This reserve is non-distributable other than in liquidation. When the relevant assets are disposed of or written off, the original transfers from the statutory public welfare fund are reversed. In 2006, the Company did not utilize the statutory public welfare fund (2005: RMB Nil). As at December 31, 2006, the net book value of assets acquired utilizing the statutory public welfare fund was RMB 30,568 (2005: RMB 33,925).

24. SHARE PREMIUM AND RESERVES *(continued)*

Note e

This reserve represents gifts or grants received from China Petrochemical Corporation, the ultimate parent company and which are required to be included in this reserve fund by PRC regulations.

Note f

The transfer to this reserve from the retained profits is subject to the approval by shareholders at general meetings. Its usage is similar to that of statutory surplus reserve.

Note g

Effective January 1, 2002, land use rights which are included in lease prepayments are carried at historical cost base. Accordingly, the surplus on the revaluation of land use rights net of deferred tax asset is reversed to shareholders' equity. Under PRC Accounting Rules and Regulations, land use rights are carried at revalued amounts.

Note h

The fair value reserve comprises the change in the fair value of available-for-sale securities, net of deferred tax, at the balance sheet date, which is based on reliably measured fair values at year end, whereas no such information was available in prior years.

Note i

According to the Company's Articles of Association, the reserve available for distribution is the lower of the amount determined under PRC Accounting Rules and Regulations and the amount determined under IFRSs. As of December 31, 2006, the reserve available for distribution was RMB 4,516,774 (2005: RMB 4,573,608). Final dividend of RMB 288,000 (2005: RMB 720,000) in respect of the financial year 2006 was declared after the balance sheet date.

25. COMMITMENTS AND CONTINGENCIES

(a) *Capital commitments*

The Group had capital commitments outstanding at December 31, 2006 not provided for in the financial statements as follows:

Property, plant and equipment

Contracted but not provided for	398,335
Authorized by the Board but not contracted for	<u>2,061,660</u>
	<u>2,459,995</u>

(b) *Contingent liabilities*

At December 31, 2006, the Group was contingently liable with respect to guarantees issued to banks in favour of associates and joint ventures of RMB 49,750 (2005: RMB 68,300).

Guarantees issued to banks in favour of associates and joint ventures are given to the extent of the Company's respective interest in these entities. The Group monitors the conditions that are subject to the guarantees to identify whether it is probable that a loss has occurred, and recognize any such losses under guarantees when those losses are estimable. At December 31, 2005 and 2006, it is not probable that the Group will be required to make payments under the guarantees. Thus no liability has been accrued for a loss related to the Company's obligation under the guarantees arrangement.

26. RETIREMENT SCHEMES

As stipulated by the regulations of the PRC, the Group participates in a defined contribution retirement plan organized by the Shanghai Municipal Government for its staff. The Group is required to make contributions to the retirement plan at a rate of 22% of the salaries, bonuses and certain allowances of its staff in 2006 (2005: 22%). A member of the plan is entitled to a pension equal to a fixed proportion of the salary prevailing at his retirement date. The Group has no other material obligation for the payment of pension benefits associated with this plan beyond the annual contributions described above. In addition, pursuant to a document “Lao Bu Fa (1995) No.464” dated December 29, 1995 issued by the Ministry of Labor of the PRC, the Company has set out a supplementary defined contribution retirement plan for the benefit of employees. Employees who have served the Company for five years or more may participate in this plan. The Company and participating employees make defined contributions to their pension savings accounts according to the plan. The assets of this plan are held separately from those of the Company in an independent fund administered by a committee consisting of representatives from the employees and the Company. In April 2003, the Company revised certain terms of the plan and increased the amounts of contributions. For the year ended December 31, 2006, the Group’s contribution to this plan amounted to RMB 61,692 (2005: RMB 65,685).

27. RELATED PARTY TRANSACTIONS

- (a) Most of the transactions undertaken by the Group during the year ended December 31, 2006 have been affected with such counterparties and on such terms as have been determined by China Petroleum & Chemical Corporation (“Sinopec Corp”), the immediate parent company, and relevant PRC authorities.

Sinopec Corp negotiates and agrees the terms of crude oil supply with suppliers on a group basis, which is then allocated among its subsidiaries, including the Group, on a discretionary basis. During the year ended December 31, 2006, the value of crude oil purchased in accordance with Sinopec Corp’s allocation was as follows:

	Years ended December 31,		
	2004	2005	2006
Purchases of crude oil	<u>19,563,608</u>	<u>27,180,740</u>	<u>31,223,530</u>

27. RELATED PARTY TRANSACTIONS *(continued)*

- (b) Other transactions between the Group and other related parties during the year ended December 31, 2006 were as follows:

	Years ended December 31,		
	2004	2005	2006
Sales of goods and service fee income	15,334,038	20,068,746	20,173,106
Purchases other than crude oil	961,919	2,318,351	2,579,394
Insurance premiums paid	97,332	95,521	98,643
Net withdrawal from deposits in a related party	(11,416)	(70,389)	(101,353)
Interest received and receivable	4,894	1,035	229
Loans borrowed	130,000	130,000	576,000
Loans repayment	130,000	130,000	626,000
Interest paid and payable	6,643	6,649	7,529
Transportation fees	151,163	415,497	344,928
Construction and installation fees	199,676	183,191	194,958
Proceeds from sales of property, plant & equipment	99,969	62,742	52,547
Gains from disposal of investments	—	24,063	24,308
Sales commissions	—	70,752	182,840
Net decrease of guarantees	<u>(27,212)</u>	<u>(33,586)</u>	<u>(18,550)</u>

27. RELATED PARTY TRANSACTIONS *(continued)*

(c) Deposits with related parties

	December 31,	
	2005	2006
Deposits, with maturity within 3 months	181,266	79,913

(d) Loans with related parties

	December 31,	
	2005	2006
Short-term loans	30,000	—
Long-term loans	100,000	—
	130,000	—

(e) Key management personnel compensation and post-employment benefit plans

	Year ended December 31,	
	2005	2006
Short-term employee benefits	3,493	4,582
Post-employment benefits	31	31
	3,524	4,613

Post-employment benefits are included in “contributions to defined contribution retirement plans” as disclosed in Note 27(f).

(f) Contributions to defined contribution retirement plans

The Group participates in defined contribution retirement plans organized by municipal governments for its staff. The contributions to defined contribution retirement plans are as follows:

	2005	2006
	RMB'	RMB'
	000	000
Municipal retirement scheme costs	165,046	207,071
Supplementary retirement scheme costs	65,685	61,692

At December 31, 2005 and December 31, 2006, there was no material outstanding contribution to post-employment benefit plans.

27. RELATED PARTY TRANSACTIONS *(continued)*

(g) Transactions with other state-owned entities in the PRC

The Group is a state-controlled enterprise and operates in an economic regime currently dominated by entities directly or indirectly controlled by the PRC government (collectively referred as “state-controlled entities”) through its government authorities, agencies, affiliations and other organizations.

Apart from transactions with related parties, the Group has transactions with other state-controlled entities include but are not limited to the following:

- sales and purchase of goods and ancillary materials;
- rendering and receiving services;
- lease of assets, purchase of property, plant and equipment;
- placing deposits and obtaining finance; and
- use of public utilities.

These transactions are conducted in the ordinary course of the Group’s business on terms comparable to those with other entities that are not state controlled. The Group has established its procurement policies, pricing strategy and approval process for purchases and sales of products and services which do not depend on whether the counterparties are state-controlled entities or not.

Having considered the potential for transactions to be impacted by related party relationships, the entity’s pricing strategy, procurement policies and approval processes, and the information that would be necessary for an understanding of the potential effect of the related party relationship on the financial statements, the directors are of the opinion that the following transactions require disclosure of numeric details.

27. RELATED PARTY TRANSACTIONS (continued)

(g) Transactions with other state-owned entities in the PRC (continued)

(i) Transactions with other state-controlled energy and chemical companies

The Group's major domestic suppliers of crude oil are China National Offshore Oil Corporation and its subsidiaries ("CNOOC Group"), which are state-controlled entities.

During the year ended December 31, 2006, the aggregate amount of crude oil purchased by the Group's refining segment from CNOOC Group was RMB 1,682,519 (2005: RMB 2,095,315).

The amounts due from/to CNOOC Group are nil as at December 31, 2006 (2005: Nil).

(ii) Transactions with state-controlled banks

The Group deposits its cash with several state-controlled banks in the PRC. The Group also obtains short-term and long-term loans from these banks in the ordinary course of business. The interest rates of the bank deposits and loans are regulated by the People's Bank of China. The Group's interest income from and interest expenses to these state-controlled banks in the PRC are as follows:

	<u>2005</u>	<u>2006</u>
Interest income	39,315	56,597
Interest expenses	<u>285,647</u>	<u>324,267</u>

The amounts of cash deposited at and loans from state-controlled banks in the PRC are summarized as follows:

	<u>2005</u>	<u>2006</u>
Cash and cash equivalents at state-controlled banks in the PRC	<u>924,887</u>	<u>731,971</u>
Short-term loans and current portion of long-term loans	3,528,295	2,245,225
Long-term loans excluding current portion of long-term loans	<u>1,256,735</u>	<u>983,710</u>
Total loans from state-controlled banks in the PRC	<u>4,785,030</u>	<u>3,228,935</u>

28. OPERATING SEGMENT DATA

Segment information is presented in respect of the Group's business segments. The format is based on the Group's management and internal reporting structure. In view of the fact that the Company and its subsidiaries operate mainly in the PRC, no geographical segment information is presented.

The Group evaluates performance based on operating profits before income tax and non-operating income and expenses. Certain administrative expenses are allocated based on the percentage of sales.

Inter-segment transfer pricing is based on cost plus an appropriate margin, as specified by Group policy.

Segment results, assets and liabilities include items directly attributable to a segment as well as those that can be allocated on a reasonable basis. Unallocated items mainly comprise income-earning assets and revenue, interest-bearing loans, borrowings and expenses, and corporate assets and expenses.

Segment capital expenditure is the total cost incurred during the year to acquire segment assets that are expected to be used for more than one period.

The Group principally operates in four operating segments: synthetic fibers, resins and plastics, intermediate petrochemicals and petroleum products. All of the Group's products are produced through intermediate steps from the principal raw material of crude oil. The specific products of each segment are as follows:

- (a) The synthetic fibers segment produces primarily polyester and acrylic fibers mainly used in the textile and apparel industries.
- (b) The resins and plastics segment produces primarily polyester chips, low density polyethylene resins and films, polypropylene resins and PVA granules. The polyester chips are used in the processing of polyester fibers and construction coating materials and containers. Low density polyethylene resins and plastics are used in cable jacketing, sheeting, the manufacture of moulded products, such as housewares and toys and for agricultural and packaging uses. Polypropylene resins are used in the manufacturing of extruded films or sheets and injection moulded products such as housewares, toys and household electric appliance and automobile parts.
- (c) The intermediate petrochemicals segment primarily produces ethylene and benzene. Most of the intermediate petrochemicals produced by the Group are used by the Group as raw materials in the production of other petrochemicals, resins, plastics and synthetic fibers. A portion of the intermediate petrochemicals as well as certain by-products of the production process are sold to outside customers.

28. OPERATING SEGMENT DATA *(continued)*

- (e) The Group's petroleum products segment has crude oil distillation facilities used to produce vacuum and atmospheric gas oils used as feedstocks of the Group's downstream processing facilities. Residual oil and low octane gasoline fuels are produced primarily as a co-product of the crude oil distillation process. A proportion of the residual oil is further processed into qualified refined gasoline and diesel oil. In addition, the Group produces a variety of other transportation, industrial and household heating fuels, such as diesel oils, jet fuels, heavy oils and liquefied petroleum gases.
- (d) All other operating segments represent the operating segments which do not meet the quantitative threshold for determining reportable segments. These include sales of consumer products, services and a variety of other commercial activities, which are not allocated to the above four operating segments.

Most of the Group's sales and concentrations of credit risk (see Note 30(b)) are with affiliates of Sinopec Corp or other state-owned enterprises. Export sales accounted for approximately, 0.2%, 0.2% and 0.5% of total sales in 2004, 2005 and 2006 respectively.

28. OPERATING SEGMENT DATA (continued)

Reportable information on the Group's operating segments is as follows:

	Years ended December 31,		
	2004	2005	2006
Sales and other income			
Manufactured Products			
Synthetic Fibers			
External sales	4,777,981	4,781,787	4,727,261
Intersegment sales	63	79	71
Total	4,778,044	4,781,866	4,727,332
Resins and Plastics			
External sales	12,154,361	14,010,287	15,800,015
Intersegment sales	19,952	53,020	63,767
Total	12,174,313	14,063,307	15,863,782
Intermediate Petrochemicals			
External sales	5,941,589	6,586,556	6,800,577
Intersegment sales	9,753,690	13,848,105	14,536,675
Total	15,695,279	20,434,661	21,337,252
Petroleum Products			
External sales	13,692,352	18,616,544	19,977,755
Intersegment sales	846,488	1,064,616	1,187,744
Other income	—	632,820	282,142
Total	14,538,840	20,313,980	21,447,641
All others			
External sales	2,836,250	1,960,729	3,293,877
Intersegment sales	3,452,657	3,687,428	3,582,206
Total	6,288,907	5,648,157	6,876,083
Eliminations of intersegment sales	(14,072,850)	(18,653,248)	(19,370,463)
Consolidated sales and other income	<u>39,402,533</u>	<u>46,588,723</u>	<u>50,881,627</u>

External sales include sales to other Sinopec Corp group companies.

28. OPERATING SEGMENT DATA (continued)

	Years ended December 31,		
	2004	2005	2006
Profit from operations			
Synthetic Fibers	250,419	263,359	196,255
Resins and Plastics	1,886,537	1,490,740	1,162,103
Intermediate Petrochemicals	1,550,796	981,025	680,425
Petroleum Products	986,578	(446,867)	(1,697,730)
All others	350,822	239,703	211,854
Profit from operations	5,025,152	2,527,960	552,907
Share of (losses)/profits of associates and jointly controlled entities	(36,915)	(60,968)	576,682
Net financing costs	(292,008)	(179,398)	(165,389)
	(328,923)	(240,366)	411,293
Profit from ordinary activities before taxation	4,696,229	2,287,594	964,200
Income tax	(637,061)	(366,300)	(53,238)
Net income	4,059,168	1,921,294	910,962
Attributable to:			
Equity shareholders of the Company	3,971,103	1,850,449	844,407
Minority interests	88,065	70,845	66,555
	4,059,168	1,921,294	910,962

28. OPERATING SEGMENT DATA (continued)

	December 31,	
	2005	2006
Assets		
Segment assets		
Synthetic Fibers	3,052,522	2,877,473
Resins and Plastics	3,326,289	3,115,456
Intermediate Petrochemicals	5,450,842	5,876,117
Petroleum Products	8,055,388	8,507,134
All others	<u>2,173,132</u>	<u>2,263,875</u>
Total segment assets	22,058,173	22,640,055
Interest in associates and jointly controlled entities	2,130,803	2,787,795
Unallocated:		
(including Cash and cash equivalents, Deposits, Income tax recoverable, Investments, Deferred tax assets, Investment property and Goodwill)	<u>2,621,395</u>	<u>1,978,210</u>
Consolidated assets	<u>26,810,371</u>	<u>27,406,060</u>
	December 31,	
	2005	2006
Liabilities		
Segment liabilities		
Synthetic Fibers	226,760	254,614
Resins and Plastics	664,392	851,001
Intermediate Petrochemicals	312,346	366,284
Petroleum Products	882,828	1,076,017
All others	<u>92,981</u>	<u>177,411</u>
Total segment liabilities	2,179,307	2,725,327
Unallocated:		
(including Loans and borrowings, Income tax payable and Deferred income)	<u>5,453,624</u>	<u>5,368,377</u>
Consolidated liabilities	<u>7,632,931</u>	<u>8,093,704</u>

28. OPERATING SEGMENT DATA (continued)

	Years ended December 31,		
	2004	2005	2006
Depreciation and amortization			
Synthetic Fibers	250,930	222,910	236,559
Resins and Plastics	356,097	350,625	353,321
Intermediate Petrochemicals	630,467	596,717	664,667
Petroleum Products	399,200	368,210	407,835
All others	177,581	167,192	178,008
Segment depreciation and amortization	1,814,275	1,705,654	1,840,390
Unallocated:	1,036	12,847	12,678
Consolidated depreciation and amortization	1,815,311	1,718,501	1,853,068

	Years ended December 31,		
	2004	2005	2006
Impairment losses			
Synthetic Fibers	34,345	—	50,000
Consolidated impairment losses	34,345	—	50,000

	Years ended December 31,		
	2004	2005	2006
Total capital expenditures for segment long-lived assets			
Synthetic Fibers	555,441	172,106	145,513
Resins and Plastics	124,768	17,323	45,418
Intermediate Petrochemicals	378,542	497,787	1,083,542
Petroleum Products	469,080	335,586	586,570
All others	165,783	104,003	147,736
Total segment capital expenditures	1,693,614	1,126,805	2,008,779
Unallocated:	512,343	16,122	—
Consolidated capital expenditures for segment long-lived assets	2,205,957	1,142,927	2,008,779

29. ACCOUNTING ESTIMATES AND JUDGEMENTS

The Group's financial condition and results of operations are sensitive to accounting methods, assumptions and estimates that underlie the preparation of the financial statements. The Group bases the assumptions and estimates on historical experience and on various other assumptions that the Group believes to be reasonable and which form the basis for making judgements about matters that are not readily apparent from other sources. On an on-going basis, management evaluates its estimates. Actual results may differ from those estimates as facts, circumstances and conditions change.

The selection of critical accounting policies, the judgements and other uncertainties affecting application of those policies and the sensitivity of reported results to changes in conditions and assumptions are factors to be considered when reviewing the financial statements. The principal accounting policies are set forth in Note 2. The Group believes the following critical accounting policies involve the most significant judgements and estimates used in the preparation of the financial statements.

Impairments for long lived assets

If circumstances indicate that the net book value of a long-lived asset may not be recoverable, the asset may be considered "impaired", and an impairment loss may be recognized in accordance with IAS 36 "Impairment of Assets". The carrying amounts of long-lived assets are reviewed periodically in order to assess whether the recoverable amounts have declined below the carrying amounts. These assets are tested for impairment whenever events or changes in circumstances indicate that their recorded carrying amounts may not be recoverable. When such a decline has occurred, the carrying amount is reduced to recoverable amount. For goodwill, the recoverable amount is estimated annually. The recoverable amount is the greater of the net selling price and the value in use. It is difficult to precisely estimate selling price because quoted market prices for the Group's assets are not readily available. In determining the value in use, expected cash flows generated by the assets are discounted to their present value, which requires significant judgement relating to level of sale volume, selling price and amount of operating costs. The Group uses all readily available information in determining an amount that is a reasonable approximation of recoverable amount, including estimates based on reasonable and supportable assumptions and projections of sale volume, selling price and amount of operating costs.

Depreciation

Property, plant and equipment are depreciated on a straight-line basis over the estimated useful lives of the assets, after taking into account the estimated residual values. The Group reviews the estimated useful lives of the assets regularly in order to determine the amount of depreciation expense to be recorded during any reporting period. The useful lives are based on the Group's historical experience with similar assets and taking into account anticipated technological changes. The depreciation expense for future periods is adjusted if there are significant changes from previous estimates.

29. ACCOUNTING ESTIMATES AND JUDGEMENTS *(continued)*

Impairment for bad and doubtful debts

The Group estimates impairment losses for bad and doubtful debts resulting from the inability of the customers to make the required payments. The Group bases the estimates on the aging of the accounts receivable balance, customer credit-worthiness, and historical write-off experience. If the financial condition of the customers were to deteriorate, actual write-offs would be higher than estimated.

30. FINANCIAL INSTRUMENTS

Financial assets of the Group include cash and cash equivalents, deposits with banks, investments, trade debtors, bills receivable, deposits, other debtors and prepayments and amounts due from related companies. Financial liabilities of the Group include loans and borrowings, trade creditors, bills payable, other creditors and amounts due to related companies. The Group does not hold or issue financial instruments for trading purposes. The Group had no positions in derivative contracts that are designated and qualified as hedging instruments at December 31, 2005 and 2006.

(a) Interest rate risk

The interest rates and terms of repayment of loans of the Group are disclosed in Note 22.

(b) Credit risk

The Group's financial instruments do not represent a concentration of credit risk because the Group deals with a variety of major financial institutions with good credit ratings, and its trade debtors are spread among a number of major industries and customers.

(c) Foreign currency risk

The Group has foreign currency risk as certain loans and cash and cash equivalents are denominated in foreign currencies, principally U.S. dollars and Hong Kong dollars. Depreciation or appreciation of Renminbi against foreign currencies will affect the Group's financial position and results of operations.

Other than the amounts as disclosed in Note 22, the amounts of other financial assets and liabilities of the Group are substantially denominated in the functional currency of respective entity of the Group.

30. FINANCIAL INSTRUMENTS (continued)

(d) Fair value

The following table presents the carrying amounts and fair values of the Group's long-term bank loans at December 31, 2005 and 2006:

Liabilities	2005		2006	
	Carrying amount	Fair value	Carrying amount	Fair value
Long-term bank loans	<u>2,850,466</u>	<u>2,804,295</u>	<u>1,480,299</u>	<u>1,445,950</u>

Long-term bank loans – the fair values are estimated based on applying a discounted cash flow using current market interest rates for similar financial instruments.

Unquoted equity securities are individually and in the aggregate not material to the Group's financial condition or results of operations. There are no listed market prices for such interests in the PRC and, accordingly, a reasonable estimate of fair value could not be made without incurring excessive costs.

The fair values of cash, trade debtors, bills receivable, deposits, other debtors, trade creditors, other creditors and amounts due to/from related companies are not materially different from their carrying amounts.

Time deposits and short-term loans and borrowings – the carrying value is estimated to approximate fair value based on the nature or short-term maturity of these instruments.

Fair value estimates are made at a specific point in time and based on relevant market information and information about the financial instrument. These estimates are subjective in nature and involve uncertainties and matters of significant judgment and therefore cannot be determined with precision. Changes in assumptions could significantly affect the estimates.

31. POSSIBLE IMPACT OF AMENDMENTS, NEW STANDARDS AND INTERPRETATIONS ISSUED BUT NOT YET EFFECTIVE FOR THE ANNUAL ACCOUNTING PERIOD ENDED DECEMBER 31, 2006

Up to the date of issue of these financial statements, the IASB has issued the following amendments, new standards and interpretations which are not yet effective for the annual accounting period ended December 31, 2006 and which have not been adopted in these financial statements:

	<u>Effective for accounting period beginning on or after</u>
IFRS 7, Financial instruments: disclosures	January 1, 2007
IFRS 8, Operating Segments	January 1, 2009
IFRIC 7, Applying the restatement approach under IAS 29, Financial reporting in hyperinflationary economies	March 1, 2006
IFRIC 8, Scope of IFRS 2	May 1, 2006
IFRIC 9, Reassessment of Embedded Derivatives	June 1, 2006
Amendment to IAS 1, Presentation of financial statements: capital disclosures	January 1, 2007
IFRIC 10, Interim financial reporting and impairment	November 1, 2006
IFRIC 11, IFRS 2 - Group and treasury share transaction	March 1, 2007
IFRIC 12, Service concession arrangements	January 1, 2008

The Group is in the process of making an assessment of what the impact of these amendments, new standards and new interpretations is expected to be in the period of initial application. Up to the date of issuance of these financial statements, the Group believes that the adoption of IFRIC 7, IFRIC 8, IFRIC 9, the amendment to IAS 1, IFRIC 10, IFRIC 11 and IFRIC 12 are not applicable to any of the Group's operations and that the adoption of the remainder of the above new standards and new interpretations is unlikely to have a significant impact on the Group's results of operations and financial position.

32. NON-ADJUSTING POST BALANCE SHEET EVENTS

Pursuant to the PRC enterprise income tax passed by the Tenth National People's Congress on March 16, 2007, the new enterprise income tax rates for domestic and foreign enterprises are unified at 25% and will be effective from January 1, 2008. The impact of such change of enterprise income tax rate on the Group's consolidated financial statements will depend on detailed pronouncements that are subsequently issued. Since implementation and transitional guidance applicable to the Group has not yet been announced, the Group cannot reasonably estimate the financial impact of the new law to the Group at this stage.

33. PARENT COMPANIES

The Directors consider the immediate parent company and the ultimate parent company at December 31, 2006 to be China Petroleum & Chemical Corporation and China Petrochemical Corporation, respectively, which are incorporated in the PRC. China Petroleum & Chemical Corporation produces financial statements available for public use.

**34. SIGNIFICANT DIFFERENCES BETWEEN IFRSs AND ACCOUNTING PRINCIPLES
GENERALLY ACCEPTED IN THE UNITED STATES OF AMERICA (“U.S. GAAP”)**

The Group’s accounting policies conform with IFRSs which differ in certain significant respects from U.S. GAAP. Information relating to the nature and effect of such differences are set out below.

(a) Foreign exchange gains and losses

Under IFRSs, foreign exchange differences on funds borrowed for construction are capitalized as property, plant and equipment to the extent that they are regarded as an adjustment to interest costs during the construction period. In the years ended December 31, 2004, 2005 and 2006, no foreign exchange differences were capitalized to property, plant and equipment. Under U.S. GAAP, all foreign exchange gains and losses on foreign currency debt are included in current earnings. Due to the effect of foreign exchange differences capitalized and fully amortized under IFRSs, the balances of cost and accumulated depreciation of property, plant and equipment as at December 31, 2006 under IFRSs were higher than the balances under U.S. GAAP by RMB365,258 and RMB365,258 respectively (December 31, 2005: RMB365,258 and RMB 365,258 respectively).

(b) Capitalization of property, plant and equipment

In certain years prior of those presented herein, certain adjustments arose between IFRSs and the U.S. GAAP with regard to the capitalization of interest and pre-production results under IFRSs, that were reversed and expensed under U.S. GAAP. For the periods presented herein, no adjustments related to the capitalization of construction costs, including capitalized interest, are necessary. The U.S. GAAP adjustment for 2004 represents the amortization effect of such originating adjustments described above.

(c) Revaluation of property, plant and equipment

In the years prior to those presented herein, the property, plant and equipment of the Company were revalued to reflect the current fair value resulting in a revaluation surplus recorded in the Company’s financial statements. Additional depreciation charges have been taken in the years ended December 31, 2004, 2005 and 2006 on the revaluation surplus of RMB 1,576,330.

Under U.S. GAAP, property, plant and equipment are stated at historical cost less accumulated depreciation. However, as a result of the tax deductibility of the revaluation, a deferred tax asset related to the reversal of the revaluation surplus is created under U.S. GAAP with a corresponding increase in shareholders’ equity.

34. SIGNIFICANT DIFFERENCES BETWEEN IFRSS AND U.S. GAAP *(continued)*

(d) Capitalized interest on investment in associates

Under IFRSs, an investment accounted for by the equity method is not considered a qualifying asset for which interest is capitalized. Under U.S. GAAP, an investment accounted for by the equity method while the investee has activities in progress necessary to commence its planned principal operations, provided that the investee's activities include the use of funds to acquire qualifying assets for its operations, is a qualifying asset for which interest is initially capitalized and subsequently amortized when the operation of the qualifying assets begin.

(e) Goodwill

With effect from January 1, 2005, in accordance with IFRS 3 and IAS 36, the Group no longer amortizes positive goodwill. Such goodwill is tested annually for impairment, including in the year of its initial recognition, as well as when there are indications of impairment. Impairment losses are recognized when the carrying amount of the cash generating unit to which the goodwill has been allocated exceeds its recoverable amount.

Under U.S. GAAP, with reference to Statement of Financial Accounting Standards No. 142, "Goodwill and Other Intangible Assets" ("SFAS No. 142"), goodwill was no longer amortized beginning January 1, 2002, the date that SFAS No. 142 was adopted. Instead, goodwill has been reviewed for impairment upon adoption of SFAS No. 142 and annually thereafter. In addition, under U.S. GAAP, the unallocated negative goodwill that existed at the date of adoption of SFAS No. 142 was written off effective January 1, 2002 as a cumulative effect of a change in accounting principle.

As a result, there are no differences in respect of goodwill amortization between IFRSs and U.S. GAAP effective January 1 2005. The difference in the shareholders' equity represents the three years of amortization of positive goodwill during the period from January 1, 2002 to December 31, 2004 under IFRSs.

(f) Presentation of minority interests

Under IFRSs, minority interests at the balance sheet date are presented in the consolidated balance sheet within equity, separately from the equity attributable to the equity shareholders of the Company, and minority interests in the results of the Group for the year are presented in the consolidated statement of income as an allocation of the total net income for the year between the minority interests and the equity shareholders of the Company. Under U.S. GAAP, minority interests at the balance sheet date are presented in the consolidated balance sheet either as liabilities or separately from liabilities and equity. Minority interests in the results of the Group for the year are also separately presented in the consolidated statement of income as a deduction before arriving at net income.

34. SIGNIFICANT DIFFERENCES BETWEEN IFRSS AND U.S. GAAP *(continued)*

(g) Condensed consolidated statements of cash flows

The Group applies IAS 7 “Cash Flow Statements”. Its objectives and principles are similar to those set out in SFAS No. 95, “Statement of Cash Flows” (“SFAS 95”). The principal differences between the standards relate to classification. Interest income received and investment income received classified as investing activities under IFRS would be classified as operating activities under U.S. GAAP.

(h) Basic earnings per share

The calculation of basic earnings per share is based on the net income under U.S. GAAP of RMB 850,024 (2005: RMB 1,869,384; 2004: RMB 4,146,065) and the number of shares in issue during the year of 7,200,000,000 (2005: 7,200,000,000; 2004: 7,200,000,000). Basic earnings per ADS is calculated on the basis that one ADS is equivalent to 100 shares.

The amount of diluted earnings per share is not presented as there were no dilutive potential ordinary shares in existence for the three years.

(i) Recently issued accounting standards

SFAS No. 157

In September 2006, the FASB issued SFAS No. 157, “Fair Value Measurements”. This Statement defines fair value, establishes a framework for measuring fair value in generally accepted accounting principles, and expands disclosures about fair value measurements. This Statement applies under other accounting pronouncements that require or permit fair value measurements, the FASB having previously concluded in those accounting pronouncements that fair value is the relevant measurement attribute. Accordingly, this Statement does not require any new fair value measurements. However, for some entities, the application of this Statement will change current practice. This Statement is effective for financial statements issued for fiscal years beginning after November 15, 2007. Management is in the process of evaluating the potential impact of this standard.

34. SIGNIFICANT DIFFERENCES BETWEEN IFRSs AND U.S. GAAP *(continued)*

(i) Recently issued accounting standards *(continued)*

SFAS No. 159

In February 2007, the FASB issued SFAS No. 159, “The Fair Value Option for Financial Assets and Financial Liabilities”, which permits entities to choose to measure many financial instruments and certain other items at fair value. SFAS No. 159 will be effective as of the beginning of an entity’s first fiscal year that begins after November 15, 2007. Management is in the process of determining whether it will elect the fair value option allowed by the Standard.

FIN No. 48

In June 2006, the FASB issued FIN 48, “Accounting for Uncertainty in Income Taxes—an Interpretation of FASB Statement No. 109”, which clarifies the accounting for uncertainty in tax positions. This interpretation requires that the entities recognize in the financial statements the impact of a tax position, if that position is more likely than not of being sustained upon examination, based on the technical merits of the position. FIN 48 will be effective for the fiscal years beginning after December 15, 2006. Management is in the process of evaluating the potential impact of this interpretation.

Staff Accounting Bulletin No. 108 (“SAB 108”)

In September 2006, the SEC issued SAB 108, “Considering the Effects of Prior Year Misstatements when Quantifying Misstatements in Current Year Financial Statements” (“SAB 108”). SAB 108 provides guidance on the consideration of the effects of prior year misstatements in quantifying current year misstatements for the purpose of a materiality assessment. SAB 108 establishes an approach that requires quantification of financial statement errors based on the effects of each on a company’s balance sheet and statement of operations and the related financial statement disclosures. The Company adopted SAB 108 in 2006 which had no impact on the Company’s consolidated financial position, results of operations or cash flows.

34. SIGNIFICANT DIFFERENCES BETWEEN IFRSs AND U.S. GAAP *(continued)*

(j) Additional information required by U.S. GAAP

As of December 31, 2006, certain subsidiaries of the Company established valuation allowances against tax losses carried forward for PRC income tax purpose totaling RMB 63,055, which are available to offset their future PRC taxable income, if any. The net losses, if not utilized, will expire in 2008 through 2011.

The valuation allowance for deferred tax assets as of December 31, 2004, 2005, and 2006 was RMB 6,322, RMB 13,412 and RMB 20,808, respectively. The net change in the total valuation allowance for each of the years ended December 31, 2004, 2005 and 2006, was an increase of RMB 3,487, RMB 7,090 and RMB 7,396, respectively. The valuation allowance at December 31, 2005 and 2006 was primarily related to net operating loss carryforwards that, in the judgment of management, are not more likely than not to be realized. In assessing the realizability of deferred tax assets, management considers whether it is more likely than not that some or all of the deferred tax assets will not be realized. The ultimate realization of deferred tax assets depends on the generation of future taxable income during the periods in which those temporary differences are deductible. Management considers the scheduled reversal of deferred tax liabilities (including the impact of available carryback and carryforward periods), projected taxable income, and tax planning strategies in making this assessment. In order to fully realize the deferred tax asset, the Company will need to generate future taxable income prior to the expiration of the deferred tax assets governed by the tax code. Taxable income for the years ended December 31, 2004, 2005, and 2006 was RMB 4,771,812, RMB 2,248,450, and RMB 443,939, respectively. Based on the level of historical taxable income and projections for future taxable income over the periods for which the deferred tax assets are deductible, management believes that it is more likely than not that the Company will realize the benefits of these deductible differences, net of the existing valuation allowances at December 31, 2006. The amount of the deferred tax asset considered realizable; however, could be reduced in the near term if estimates of future taxable income during the carryforward period are reduced.

34. SIGNIFICANT DIFFERENCES BETWEEN IFRSs AND U.S. GAAP (continued)

The effect on the profit attributable to equity shareholders of the Company of significant differences between IFRSs and U.S. GAAP is as follows:

	<i>Note</i>	<u>2004</u> <u>RMB</u>	<u>2005</u> <u>RMB</u>	<u>2006</u> <u>RMB</u>
Net income attributable to equity shareholders of the Company under IFRSs		3,971,103	1,850,449	844,407
U.S. GAAP adjustments:				
Foreign exchange gains and losses	(a)	2,473	—	—
Capitalization of property, plant and equipment	(b)	21,707	—	—
Depreciation charge on revalued property, plant and equipment	(c)	129,995	15,881	15,881
Capitalized interest on investment in associates, net of amortization effect	(d)	36,841	6,396	(9,273)
Goodwill amortization	(e)	13,448	—	—
Negative goodwill amortization	(e)	(849)	—	—
Deferred tax effect of the above adjustments		<u>(28,653)</u>	<u>(3,342)</u>	<u>(991)</u>
Net income under U.S. GAAP		<u>4,146,065</u>	<u>1,869,384</u>	<u>850,024</u>
Basic earnings per share under U.S. GAAP	(g)	<u>RMB 0.58</u>	<u>RMB 0.26</u>	<u>RMB 0.12</u>
Basic earnings per ADS under U.S. GAAP	(g)	<u>RMB 57.58</u>	<u>RMB 25.96</u>	<u>RMB 11.81</u>

34. SIGNIFICANT DIFFERENCES BETWEEN IFRSs AND U.S. GAAP *(continued)*

The effect on total equity attributable to equity shareholders of the Company of significant differences between IFRSs and U.S. GAAP is as follows:

	<i>Note</i>	<u>At December 31,</u>	
		<u>2005</u>	<u>2006</u>
		<u>RMB</u>	<u>RMB</u>
Total equity attributable to equity shareholders of the Company under IFRSs		18,829,987	18,976,343
U.S. GAAP adjustments:			
Revaluation of property, plant and equipment	(c)	(47,640)	(31,759)
Capitalized interest on investment in associates, net of amortization effect	(d)	95,596	86,323
Goodwill	(e)	40,344	40,344
Effect of U.S. GAAP adjustment on deferred tax assets		7,146	4,764
Effect of U.S. GAAP adjustment on deferred tax liabilities		<u>(14,339)</u>	<u>(12,948)</u>
Total equity attributable to equity shareholders of the Company under U.S. GAAP		<u>18,911,094</u>	<u>19,063,067</u>

Shanghai Secco Petrochemical Company Limited

Index

Years Ended December 31, 2004 (Unaudited), 2005 (Unaudited) and 2006

Financial Statements of Shanghai Secco Petrochemical Company Limited (1)

	<u>Page</u>
<u>Independent Auditors' Report</u>	F-65
<u>Balance Sheets</u> <u>December 31, 2005 (Unaudited) and 2006</u>	F-66
<u>Income and profit appropriation statements</u> <u>Years Ended December 31, 2004 (Unaudited), 2005 (Unaudited) and 2006</u>	F-68
<u>Cash flow statements</u> <u>Years Ended December 31, 2004 (Unaudited), 2005 (Unaudited) and 2006</u>	F-69
<u>Notes on the financial statements</u>	F-72

(1) The financial statements of Shanghai Secco Petrochemical Company Limited, an investee of Sinopec Shanghai Petrochemical Company Limited., are included in this Annual Report on Form 20-F of Sinopec Shanghai Petrochemical Company Limited to comply with Rule 3-09 of Regulation S-X of the U.S. Federal Securities Laws.

Independent Auditors' Report

The Board of Directors and Shareholders of
Shanghai Secco Petrochemical Company Limited:

We have audited the accompanying balance sheet of Shanghai Secco Petrochemical Company Limited ("the Company") as of December 31, 2006, and the related income and profit appropriation statement, and cash flow statement for the year ended December 31, 2006, all expressed in Renminbi. These financial statements are the responsibility of the Company's management. Our responsibility is to express an opinion on the financial statements based on our audit.

We conducted our audit in accordance with the auditing standards generally accepted in United States of America. Those standards require that we plan and perform the audit to obtain reasonable assurance about whether the financial statements are free of material misstatement. An audit includes consideration of internal control over financial reporting as a basis for designing audit procedures that are appropriate in the circumstances, but not for the purpose of expressing an opinion on the effectiveness of the Company's internal control over financial reporting. Accordingly, we express no such opinion. An audit also includes examining, on a test basis, evidence supporting the amounts and disclosures in the financial statements, assessing the accounting principles used and significant estimates made by management, as well as evaluating the overall financial statement presentation. We believe that our audit provides a reasonable basis for our opinion.

In our opinion, the financial statements referred to above present fairly, in all material respects, the financial position of Shanghai Secco Petrochemical Company Limited as of December 31, 2006, and the results of its operation and its cash flow for the year then ended in conformity with the Accounting Standards for Business Enterprises and the Accounting Regulations for Business Enterprises issued by the Ministry of Finance of the People's Republic of China.

PRC Accounting Rules and Regulations vary in certain significant respects from accounting principles generally accepted in the United States of America. Information relating to the nature of such differences is presented in Note 29 to the financial statements.

KPMG
Certified Public Accountants

Hong Kong, China, February 26, 2007

Shanghai Secco Petrochemical Company Limited
 Balance sheet as of December 31, 2005 (Unaudited) and 2006
 (Expressed in Renminbi)

	Note	2005 RMB ' 000 (Unaudited)	2006 RMB ' 000
Assets			
Current assets			
Cash at bank and on hand	5	375,953	1,654,819
Short-term investment	6	—	1,454,000
Notes receivable	7	63,864	664,533
Accounts receivable	8	379,465	330,704
Other receivables	9	13,196	14,249
Payments in advance	10	123,207	264,717
Inventories	11	1,585,457	1,790,351
Total current assets		<u>2,541,142</u>	<u>6,173,373</u>
Fixed assets			
Cost		16,734,809	16,749,735
Less: Accumulated depreciation		<u>(1,010,554)</u>	<u>(2,183,291)</u>
	12	15,724,255	14,566,444
Construction in progress	13	1,671	28,027
Total fixed assets		<u>15,725,926</u>	<u>14,594,471</u>
Intangible assets and other assets			
Intangible assets	14	1,049,963	955,521
Long-term deferred expenses	15	—	37,273
Total intangible assets and other assets		<u>1,049,963</u>	<u>992,794</u>
Deferred taxation			
Deferred tax assets	16	—	17,636
Total assets		<u><u>19,317,031</u></u>	<u><u>21,778,274</u></u>

The notes on pages F-72 to F-94 form part of these financial statements.

Shanghai Secco Petrochemical Company Limited
 Balance sheet as of December 31, 2005 (Unaudited) and 2006 (continued)
 (Expressed in Renminbi)

	Note	2005 RMB' 000 (Unaudited)	2006 RMB' 000
Liabilities and investors' equity			
Current liabilities			
Bills payable		219,243	—
Accounts payable		704,711	1,075,676
Receipts in advance		197,638	372,383
Staff welfare payable		1,978	21,802
Taxes (recoverable)/payable	4(c)	(12,014)	75,102
Other payables	17	1,005,201	457,153
Other creditors		2,124	2,708
Accrued expenses		45,458	49,020
Long-term liabilities due within one year	18	—	477,769
Total current liabilities		2,164,339	2,531,613
Long-term liabilities			
Long-term loans	19	10,813,524	9,853,625
Total liabilities		<u>12,977,863</u>	<u>12,385,238</u>
Investors' equity			
Paid-in capital	20	7,095,496	7,443,585
Capital reserve	21	(14)	(509)
Surplus reserve	22	—	39,393
(Accumulated losses)/retained earnings		(756,314)	1,910,567
Total investors' equity		<u>6,339,168</u>	<u>9,393,036</u>
Total liabilities and investors' equity		<u>19,317,031</u>	<u>21,778,274</u>

These financial statements have been approved by the Board of Directors of the Company.

Didier Baudrand
 Legal Representative

Zhang Zhiliang
 General Manager

Xia Peizheng
 Chief Financial Officer

February 26, 2007

The notes on pages F-72 to F-94 form part of these financial statements.

Shanghai Secco Petrochemical Company Limited
Income and profit appropriation statement
for the years ended December 31, 2004 (Unaudited), 2005 (Unaudited) and 2006
(Expressed in Renminbi)

	Note	2004 RMB' 000 (Unaudited)	2005 RMB' 000 (Unaudited)	2006 RMB' 000
Sales from principal activities	24	165,368	12,690,197	21,777,397
Less: Cost of sales from principal activities		(166,216)	(12,117,727)	(18,025,664)
(Loss)/profit from principal activities		(848)	572,470	3,751,733
Add: Profit from other operations		—	3	186
Less: Operating expenses		(11,736)	(267,743)	(352,307)
General and administrative expenses		—	(769,685)	(278,577)
Financial expenses, net	25	—	(284,218)	(423,960)
Operating (loss)/profit		(12,584)	(749,173)	2,697,075
Add: Subsidy income	26	—	6,457	11,515
Non-operating income		—	60	543
Less: Non-operating expenses		—	(1,074)	(799)
(Loss)/profit before income tax		(12,584)	(743,730)	2,708,334
Income tax benefit	4(b)/16	—	—	17,636
Net (loss)/profit for the year		(12,584)	(743,730)	2,725,970
Add: Accumulated losses at the beginning of the year		—	(12,584)	(756,314)
(Loss)/profit available for distribution		(12,584)	(756,314)	1,969,656
Less: Surplus reserve				
- General reserve fund	23	—	—	(19,697)
- Enterprise expansion fund	23	—	—	(19,696)
Staff and workers' bonus and welfare fund	23	—	—	(19,696)
(Accumulated losses)/retained earnings carried forward		(12,584)	(756,314)	1,910,567

The notes on pages F-72 to F-94 form part of these financial statements.

Shanghai Secco Petrochemical Company Limited
Cash flow statement
for the years ended December 31, 2004 (Unaudited), 2005 (Unaudited) and 2006
(Expressed in Renminbi)

	<i>Note to the cash flow statement</i>	<u>2004 RMB' 000</u> (Unaudited)	<u>2005 RMB' 000</u> (Unaudited)	<u>2006 RMB' 000</u>
Cash flows from operating activities:				
Cash received from sale of goods		201,006	14,466,263	24,861,800
Refund of taxes		—	1,450	154
Other cash received relating to operating activities		<u>13</u>	<u>18,719</u>	<u>71,555</u>
Sub-total of cash inflows		<u>201,019</u>	<u>14,486,432</u>	<u>24,933,509</u>
Cash paid for goods		(514,990)	(14,040,129)	(19,945,622)
Cash paid to and for employees		(8,491)	(170,901)	(198,586)
Cash paid for all types of taxes		—	(40,283)	(562,294)
Other cash paid relating to operating activities		<u>(13)</u>	<u>(24,348)</u>	<u>(45,667)</u>
Sub-total of cash outflows		<u>(523,494)</u>	<u>(14,275,661)</u>	<u>(20,752,169)</u>
Net cash (outflow)/inflow from operating activities	<i>i</i>	<u>(322,475)</u>	<u>210,771</u>	<u>4,181,340</u>
Cash flows from investing activities:				
Net cash received from disposal of fixed assets, intangible assets and other long-term assets		<u>1,215</u>	—	<u>257</u>
Sub-total of cash inflows		<u>1,215</u>	—	<u>257</u>
Cash paid for acquisition of fixed assets and intangible assets and other long-term assets		(7,967,541)	(2,683,935)	(851,533)
Cash paid for acquisition of investments		—	—	(1,454,145)
Other cash paid relating to investing activities		<u>(39,505)</u>	<u>(74,373)</u>	<u>(1,586)</u>
Sub-total of cash outflows		<u>(8,007,046)</u>	<u>(2,758,308)</u>	<u>(2,307,264)</u>
Net cash outflow from investing activities		<u>(8,005,831)</u>	<u>(2,758,308)</u>	<u>(2,307,007)</u>

The notes on pages F-72 to F-94 form part of these financial statements.

Shanghai Secco Petrochemical Company Limited
Cash flow statement
for the years ended December 31, 2004 (Unaudited), 2005 (Unaudited) and 2006 (continued)
(Expressed in Renminbi)

	<i>Note to the cash flow statement</i>	<i>2004 RMB ' 000 (Unaudited)</i>	<i>2005 RMB ' 000 (Unaudited)</i>	<i>2006 RMB ' 000</i>
Cash flows from financing activities:				
Cash received from investors		2,814,096	1,092,975	347,594
Cash received from borrowings		<u>5,787,062</u>	<u>3,071,667</u>	<u>—</u>
Sub-total of cash inflows		<u>8,601,158</u>	<u>4,164,642</u>	<u>347,594</u>
Cash repayments of borrowings		—	(820,000)	(320,000)
Cash paid for interest expenses		(239,984)	(492,190)	(613,779)
Other cash paid relating to financing activities		<u>(10,613)</u>	<u>(6,905)</u>	<u>(2,424)</u>
Sub-total of cash outflows		<u>(250,597)</u>	<u>(1,319,095)</u>	<u>(936,203)</u>
Net cash inflow/(outflow) from financing activities		<u>8,350,561</u>	<u>2,845,547</u>	<u>(588,609)</u>
Effect of foreign exchange rate changes on cash		<u>3,980</u>	<u>(1,244)</u>	<u>(6,858)</u>
Net increase in cash and cash equivalents	<i>ii</i>	<u><u>26,235</u></u>	<u><u>296,766</u></u>	<u><u>1,278,866</u></u>

The notes on pages F-72 to F-94 form part of these financial statements.

Shanghai Secco Petrochemical Company Limited
Cash flow statement
for the years ended December 31, 2004 (Unaudited), 2005 (Unaudited) and 2006 (continued)
(Expressed in Renminbi)

Notes to the cash flow statement

i Reconciliation of net (loss)/profit to cash flows from operating activities

	<u>2004</u> <u>RMB ' 000</u> <i>(Unaudited)</i>	<u>2005</u> <u>RMB ' 000</u> <i>(Unaudited)</i>	<u>2006</u> <u>RMB ' 000</u>
Net (loss)/profit	(12,584)	(743,730)	2,725,970
Add: Provision for (reversal of) impairment of assets	—	15,406	(9,980)
Depreciation of fixed assets	—	998,407	1,175,032
Amortization of intangible assets	—	73,354	97,357
Amortization of long-term deferred assets	—	542,651	4,633
Loss on disposal of fixed assets	—	363	267
Increase in accrued expenses	—	—	1,103
Financial expenses	—	288,951	460,487
Increase in gross inventories	(202,821)	(1,398,042)	(194,914)
Increase in gross operating receivables	(190,868)	(370,834)	(694,471)
Increase in operating payables	83,798	804,245	633,492
Deferred taxes	—	—	(17,636)
Net cash (outflow)/inflow from operating activities	<u>(322,475)</u>	<u>210,771</u>	<u>4,181,340</u>

ii Net increase in cash

Cash at the end of the year	79,187	375,953	1,654,819
Less: Cash at the beginning of the year	<u>(52,952)</u>	<u>(79,187)</u>	<u>(375,953)</u>
Net increase in cash	<u>26,235</u>	<u>296,766</u>	<u>1,278,866</u>

The notes on pages F-72 to F-94 form part of these financial statements.

Shanghai Secco Petrochemical Company Limited
Notes on the financial statements
(Expressed in Renminbi)

1 COMPANY STATUS

Shanghai Secco Petrochemical Co., Ltd. (“the Company”) is an equity joint venture established in Shanghai in the People’s Republic of China (PRC) by China Petroleum and Chemical Corporation (“Sinopec”), Sinopec Shanghai Petrochemical Co., Ltd. (“SPC”) and BP Chemicals East China Investments Ltd. (“BPCECIL”) (registered in the United Kingdom). The Company obtained an approval certificate [Wai Jing Mao Zi Shen Zi (2001) No. 0099] from the Ministry of Commerce (formerly Ministry of Foreign Trade and Economic Co-operation) on September 13, 2001, and a business license (Qi He Hu Zong Zi No. 029541 (Shi ju)) on October 29, 2001 issued by the State Administration of Industry and Commerce of the PRC. The registered capital is USD901,440,964.

According to the joint venture agreement and articles of association, the Company’s period of operation is 50 years and its principal activities are to produce, market and sell ethylene, polyethylene, styrene, polystyrene, propylene, acrylonitrile, polypropylene, butadiene, aromatics and co-products; provide related after-sales services and technical advice with respect to such main petrochemical products and co-products; engage in polymers application development; and provide ancillary utilities services and other services to suppliers and processors. The Company commenced its manufacturing operations on March 31, 2005.

2 BASIS OF PREPARATION

The principal accounting policies adopted in the preparation of the financial statements are in conformity with the Accounting Standards for Business Enterprises and the Accounting Regulations for Business Enterprises issued by the Ministry of Finance of the PRC (MOF). The accounting policies comply with the legal and reporting requirements of the relevant government authorities. Accordingly, the basis of measurement and presentation in these financial statements may not be in compliance with the accounting principles and practices generally accepted in countries and jurisdictions other than the PRC.

3 SIGNIFICANT ACCOUNTING POLICIES

(a) Accounting year

The accounting year of the Company is from January 1 to December 31.

(b) Basis of preparation and measurement basis

The financial statements of the Company have been prepared on an accrual basis. Unless otherwise stated, the measurement basis used is historical cost.

(c) Reporting currency

The Company's reporting currency is the Renminbi.

(d) Translation of foreign currencies

Foreign currency transactions during the year are translated into Renminbi at the exchange rates quoted by the People's Bank of China and other exchange rates recognized by the state ruling at the transaction dates.

Monetary assets and liabilities denominated in foreign currencies are translated into Renminbi at the exchange rates quoted by the People's Bank of China and other exchange rates recognized by the state ruling at the balance sheet date.

Exchange gains and losses on foreign currency translation, except for the exchange gains and losses directly relating to the construction of fixed assets (see note 3(h)), are dealt with in the income statement.

(e) Cash equivalents

Cash equivalents represent short-term, highly liquid investments, which are readily convertible into known amounts of cash and are subject to an insignificant risk of change in value.

(f) Inventories

Inventories are carried at the lower of cost and net realizable value.

Cost comprises all costs of purchase, costs of conversion and other costs. Inventories are measured at their actual cost upon acquisition. The cost of inventories is calculated using the weighted average method. In addition to the purchase cost of raw materials, work in progress and finished goods include direct labor costs and an appropriate allocation of manufacturing overheads.

Any excess of the cost over the net realizable value of each class of inventories is recognized as a provision for diminution in the value of inventories. Net realizable value is the estimated selling price in the normal course of business less the estimated costs to completion and the estimated expenses and related taxes necessary to make the sale.

(g) Designated loans receivable

Designated loans receivable refer to the funds lent by the Company through financial institutions to designated borrowers with uses, amounts, terms, interest rates, etc., designated by the Company. The financial institution assists the Company to release the funds and collect the repayment on behalf of the Company.

Designated loans receivable are recorded at the amount lent out.

Interest income arising from designated loans receivable is calculated at the applicable rate on a time proportion basis and recognized in the income statement. Accrual of interest on designated loans receivable ceases when the interest is in default at the due date, and the interest previously accrued is reversed immediately in the income statement.

The Company makes provision for impairment losses on designated loans receivable (see note 3(l)). Designated loans receivable are stated in the balance sheet net of impairment losses. Designated loans receivable with terms equal to or less than one year are classified under short-term investments. Other designated loans receivable are classified under long-term investments.

(h) Fixed assets and construction in progress

Fixed assets are assets with comparatively high unit values held by the Company for use in the production of goods and for administrative purposes. They are expected to be used for more than one year.

Fixed assets are stated in the balance sheet at cost less accumulated depreciation and impairment losses (see note 3(l)). Construction in progress is stated in the balance sheet at cost less impairment losses (see note 3(l)).

All direct and indirect costs that are related to the construction of fixed assets and incurred before the assets are ready for their intended use are capitalized as construction in progress. Those costs include borrowing costs (including foreign exchange differences arising from the loan principal and the related interest) on specific borrowings for the construction of the fixed assets during the construction period.

Construction in progress is transferred to fixed assets when it is ready for its intended use. No depreciation is provided against construction in progress.

Fixed assets are depreciated using the straight-line method over their estimated useful lives. The respective estimated useful lives and the estimated rate of residual values on cost for the Company's fixed assets are as follows:

	<i>Estimated useful life</i>	<i>Estimated rate of residual value</i>
Land use right	50 years	—
Plant and buildings	10-40 years	3%
Machinery and equipment	10-28 years	3%
Office and other equipment	4-5 years	3%
Motor Vehicles	8 years	3%

(i) Operating lease charges

Rental payments under operating leases are charged as expenses on a straight-line basis over the lease term.

(j) Intangible assets

Intangible assets are stated in the balance sheet at cost less accumulated amortization and impairment losses (see note 3(1)). The cost of the intangible assets is amortized on a straight-line basis over their estimated useful lives, or the contracted beneficial period. The respective amortization periods for the intangible assets are as follows:

	<u>Estimated useful life</u>
Land use right	50 years
Patent	10 years
Computer software	5 years

(k) Long-term deferred expenses

Long-term deferred expenses represent catalyst costs, which are amortized on a straight-line basis over their beneficial periods.

(l) Provision for impairment

The carrying amounts of assets (including designated loans receivable, fixed assets, construction in progress, intangible assets and other assets) are assessed regularly at each balance sheet date to determine whether their recoverable amounts have declined below their carrying amounts. Assets are tested for impairment whenever events or changes in conditions indicate that their recorded carrying amounts may not be recoverable. When such a decline has occurred, the carrying amount is reduced to the recoverable amount. The amount by which the carrying amount is reduced is the impairment loss.

The recoverable amount is the greater of the net selling price and the present value of the estimated future cash flows arising from the continuous use of the asset and from the disposal of the asset at the end of its useful life.

Provision for impairment is calculated on an item by item basis and recognized as an expense in the income statement.

If there is an indication that there has been a change in the factors used to determine the provision for impairment and as a result the estimated recoverable amount is greater than the carrying amount of the asset, the impairment loss recognized in prior years is reversed. Reversals of impairment losses are recognized in the income statement. An impairment loss is reversed only to the extent of the asset's carrying amount that would have been determined had no impairment loss been recognized in prior years.

(m) Income tax

Income tax is recognized using the tax-effect accounting method. Income tax for the year comprises current tax paid and payable and movements in deferred tax assets and liabilities.

Current tax is calculated at the applicable tax rate on taxable income.

Deferred tax is provided using the liability method for the differences between the accounting profits and the taxable profits arising from the timing differences in recognizing income, expenses or losses between the accounting and tax regulations. When the tax rate changes or a new type of tax is levied, adjustments are made to the amounts originally recognized for the timing differences under the liability method. The current tax rates are used in arriving at the reversal amounts when the timing differences are reversed.

Deferred tax assets arising from tax losses, which are expected to be utilized against future taxable profits, are set off against the deferred tax liabilities (only for the same taxpayer within the same jurisdiction). When it is not probable that the tax benefits of deferred tax assets will be realized, the deferred tax assets are reduced to the extent that the related tax benefits are expected to be realized.

(n) Provisions and contingent liabilities

Provisions are recognized when the Company has a present obligation as a result of a past event, it is probable that an outflow of economic benefits will be required to settle the obligations and a reliable estimate can be made.

Where it is not probable that the settlement of the above obligation will cause an outflow of economic benefits, or the amount of the outflow cannot be estimated reliably, the obligation is disclosed as a contingent liability.

(o) Revenue recognition

When it is probable that the economic benefits will flow to the Company and the revenue and costs can be measured reliably, revenue is recognized in the income statement according to the following methods:

i) Sale of goods

Sales revenue is recognized when the significant risks and rewards of the ownership of goods have been transferred to the buyers. No revenue is recognized if there are significant uncertainties regarding the receipt of the consideration and the return of goods, or when the revenue and the costs incurred or to be incurred in respect of the transaction cannot be measured reliably.

-
- ii) Rendering of services

When the outcome of a transaction involving the rendering of services can be estimated reliably, revenue from the rendering of services is recognized in the income statement by reference to the stage of completion of the transaction is based on. When the outcome of the transaction involving the rendering of services cannot be estimated reliably, revenue is recognized only to the extent of the costs incurred that are expected to be recoverable.
 - iii) Interest income

Interest income is recognized on a time proportion basis with reference to the principal outstanding and the applicable rate.
 - iv) Subsidy income

Subsidy income is recognized in the income statement upon receipt of the subsidy.
 - (p) Borrowing costs

Borrowing costs incurred on specific borrowings for the construction of fixed assets are capitalised into the cost of the fixed assets during the construction period until the fixed assets are ready for their intended uses.

Except for the above, other borrowing costs are recognized as financial expenses in the income statement when incurred.
 - (q) Repair and maintenance expenses

Repair and maintenance expenses (including major overhaul expenses) are recognized in the income statement when incurred.
 - (r) Environmental preservation expenses

Environmental preservation expenses relating to circumstances arising as a result of the current or past businesses are recognized in the income statement when incurred.
 - (s) Dividends appropriated to investors

Dividends appropriated to the investors are recognized in the income and profit appropriation statement upon approval. Cash dividends approved after the balance sheet date, but before the date on which the financial statements are authorized for issue, are disclosed in the balance sheet as a separate component under investors' equity.

(t) Retirement benefits

Pursuant to the relevant laws and regulations in the PRC, the Company has joined a defined contribution retirement plan for the employees arranged by a governmental organisation. The Company makes contributions to the retirement scheme at the applicable rate based on the employees' salaries. The contributions are charged to the income statement on an accrual basis. After the payment of the contributions under the retirement plan, the Company does not have any other obligations in this respect.

(u) Related parties

If the Company has the power, directly or indirectly, to control, jointly control or exercise significant influence over another party, or vice versa, or where the Company and one or more parties are subject to common control from another party, they are considered to be related parties. Related parties may be individuals or enterprises.

4 TAXATION

(a) The types of tax applicable to the Company's sale of goods and rendering of services include business tax at 5% and value added tax (VAT) at 17%.

(b) Income tax

Income tax in the income statement represents:

	<i>2004</i> <u>RMB' 000</u> (Unaudited)	<i>2005</i> <u>RMB' 000</u> (Unaudited)	<i>2006</i> <u>RMB'</u> <u>000</u>
Deferred taxation benefit (Note 16)	—	—	<u>17,636</u>

In accordance with the State Tax Bureau notice (Guo Shui Han [2003] 420), the income tax rate applicable to the Company is 15%.

Pursuant to the Income Tax Law of the PRC for Foreign Invested Enterprises and Foreign Enterprises, starting from the year in which a taxable profit is made after the offset of deductible losses incurred in prior years, the Company is entitled to a tax holiday of a tax-free period for the first and second years and a 50% reduction in the income tax rate for the third to fifth years.

2006 is the first year that the Company incurred a taxable profit after the offset of deductible losses incurred in prior years. The effective income tax rate in 2006 is 0%.

(c) Taxes (recoverable)/payable

	<u>2005</u> <u>RMB ' 000</u>	<u>2006</u> <u>RMB ' 000</u>
	<i>(Unaudited)</i>	
Withholding business tax payable	408	2
Withholding income tax payable	556	—
Individual income tax payable	3,992	2,778
VAT (recoverable)/payable	(16,816)	73,916
Business tax payable	63	—
Others	(217)	(1,594)
Total	<u>(12,014)</u>	<u>75,102</u>

5 CASH AT BANK AND ON HAND

	<u>2005</u> <u>RMB ' 000</u>	<u>2006</u> <u>RMB ' 000</u>
	<i>(Unaudited)</i>	
Cash on hand	62	48
Demand deposits	375,891	1,654,771
Total	<u>375,953</u>	<u>1,654,819</u>

6 SHORT-TERM INVESTMENT

	<u>Additions</u> <u>in 2006</u> <u>RMB ' 000</u>	<u>Closing</u> <u>balance as at</u> <u>December 31,</u> <u>2006</u> <u>RMB ' 000</u>
Debt investments - Designated loans	1,454,000	1,454,000
Less: Provision for diminution in value	—	—
Total	<u>1,454,000</u>	<u>1,454,000</u>

In 2006, the Company entrusted China Construction Bank, Shanghai branch to grant unsecured loans. The detailed breakdown of balances as at December 31, 2006 is as follows:

<u>Borrower</u>	<u>2006</u> <u>RMB ' 000</u>	<u>Period</u>	<u>Interest rate</u>
Sinopec	391,000	2006.12.26-2007.3.26	3.30%
Sinopec	336,000	2006.12.26-2007.6.26	2.00%
BP (China) Holdings Ltd.	391,000	2006.12.26-2007.3.26	3.30%
BP Zhuhai Chemical Co., Ltd.	336,000	2006.12.26-2007.6.26	2.00%
	<u>1,454,000</u>		

7 NOTES RECEIVABLE

	<u>2005</u> <u>RMB ' 000</u> <i>(Unaudited)</i>	<u>2006</u> <u>RMB ' 000</u>
Bank acceptance bills	63,864	664,533

8 ACCOUNTS RECEIVABLE

The ageing analysis of the Company's accounts receivables is as follows:

	<u>RMB ' 000</u> <u>(Unaudited)</u>	<u>2005</u> <u>Percentage</u> <u>of total</u> <u>accounts</u> <u>receivable</u>	<u>Bad debt</u> <u>provision</u> <u>(Unaudited)</u>	<u>RMB ' 000</u>	<u>2006</u> <u>Percentage</u> <u>of total</u> <u>accounts</u> <u>receivable</u>	<u>Bad debt</u> <u>provision</u>
Within 1 year	379,465	100%	—	330,704	100%	—

9 OTHER RECEIVABLES

The ageing analysis of the Company's other receivables is as follows:

	<u>RMB ' 000</u> <u>(Unaudited)</u>	<u>2005</u> <u>Percentage</u> <u>of total</u> <u>other</u> <u>receivables</u>	<u>Bad debt</u> <u>provision</u> <u>(Unaudited)</u>	<u>RMB ' 000</u>	<u>2006</u> <u>Percentage</u> <u>of total</u> <u>other</u> <u>receivables</u>	<u>Bad debt</u> <u>provision</u>
Within 1 year	12,930	98%	—	13,541	95%	—
After 1 year but within 2 years	258	2%	—	708	5%	—
After 2 years but within 3 years	8	—	—	—	—	—
Total	13,196	100%	—	14,249	100%	—

10 PAYMENTS IN ADVANCE

Payments in advance are made for purchases.

11 INVENTORIES

	<u>2005</u> <u>RMB ' 000</u> <i>(Unaudited)</i>	<u>2006</u> <u>RMB ' 000</u>
Raw materials	877,972	864,873
Semi-finished goods	321,550	387,594
Work in progress	43,154	42,288
Finished goods	358,187	501,022
	<u>1,600,863</u>	<u>1,795,777</u>
Less: Provision for diminution in value of inventories	<u>(15,406)</u>	<u>(5,426)</u>
	<u>1,585,457</u>	<u>1,790,351</u>

Provision for diminution in value of inventories:

	<u>2005</u>			<u>2006</u>		
	<i>Semi-finished goods</i> <u>RMB ' 000</u> <i>(Unaudited)</i>	<i>Finished goods</i> <u>RMB ' 000</u> <i>(Unaudited)</i>	<i>Total</i> <u>RMB ' 000</u> <i>(Unaudited)</i>	<i>Semi-finished goods</i> <u>RMB ' 000</u>	<i>Finished goods</i> <u>RMB ' 000</u>	<i>Total</i> <u>RMB ' 000</u>
Opening balance as at January 1	—	—	—	(6,979)	(8,427)	(15,406)
Add: Provision made during the year	(6,979)	(8,427)	(15,406)	(3,279)	(2,147)	(5,426)
Less: Written back during the year - transfer out due to sales	—	—	—	6,979	8,427	15,406
Closing balance as at December 31	<u>(6,979)</u>	<u>(8,427)</u>	<u>(15,406)</u>	<u>(3,279)</u>	<u>(2,147)</u>	<u>(5,426)</u>

All the above inventories are purchased from others or self-manufactured.

	<u>2005</u> <u>RMB ' 000</u> <i>(Unaudited)</i>	<u>2006</u> <u>RMB ' 000</u>
Cost of inventories charged to costs and expenses in the income statement	<u>12,069,741</u>	<u>18,109,160</u>

12 FIXED ASSETS

	<i>Land use right</i>	<i>Plant and buildings</i>	<i>Machinery and equipment</i>	<i>Office and other equipment</i>	<i>Motor vehicles</i>	<i>Total</i>
	<i>RMB' 000</i>	<i>RMB' 000</i>	<i>RMB' 000</i>	<i>RMB' 000</i>	<i>RMB' 000</i>	<i>RMB' 000</i>
Cost:						
As at January 1, 2005 (Unaudited)	—	—	—	44,135	772	44,907
Additions	—	—	—	36,009	1,568	37,577
Transfer from construction in progress	537,041	1,247,955	14,869,101	1,951	—	16,656,048
Disposals	—	—	—	(3,723)	—	(3,723)
As at December 31 , 2005 (Unaudited)	<u>537,041</u>	<u>1,247,955</u>	<u>14,869,101</u>	<u>78,372</u>	<u>2,340</u>	<u>16,734,809</u>
Accumulated depreciation:						
As at January 1, 2005 (Unaudited)	—	—	—	(11,869)	—	(11,869)
Charge for the year	(11,031)	(63,268)	(913,716)	(12,773)	(203)	(1,000,991)
Written back on disposal	—	—	—	2,306	—	2,306
As at December 31 , 2005 (Unaudited)	<u>(11,031)</u>	<u>(63,268)</u>	<u>(913,716)</u>	<u>(22,336)</u>	<u>(203)</u>	<u>(1,010,554)</u>
Carrying amount:						
As at December 31 , 2005 (Unaudited)	<u>526,010</u>	<u>1,184,687</u>	<u>13,955,385</u>	<u>56,036</u>	<u>2,137</u>	<u>15,724,255</u>
As at January 1, 2005 (Unaudited)	<u>—</u>	<u>—</u>	<u>—</u>	<u>32,266</u>	<u>772</u>	<u>33,038</u>
	<i>Land use right</i>	<i>Plant and buildings</i>	<i>Machinery and equipment</i>	<i>Office and other equipment</i>	<i>Motor vehicles</i>	<i>Total</i>
	<i>RMB' 000</i>	<i>RMB' 000</i>	<i>RMB' 000</i>	<i>RMB' 00</i>	<i>RMB' 000</i>	<i>RMB' 000</i>
Cost:						
As at January 1, 2006	537,041	1,247,955	14,869,101	78,372	2,340	16,734,809
Additions	—	—	3,973	10,228	1,510	15,711
Transfer from construction	—	—	2,034	—	—	2,034

in progress							
Disposals	—	—	—	(2,819)	—	(2,819)	
As at December 31 , 2006	<u>537,041</u>	<u>1,247,955</u>	<u>14,875,108</u>	<u>85,781</u>	<u>3,850</u>	<u>16,749,735</u>	
Accumulated depreciation:							
As at January 1, 2006	(11,031)	(63,268)	(913,716)	(22,336)	(203)	(1,010,554)	
Charge for the year	(11,435)	(73,289)	(1,073,364)	(16,584)	(360)	(1,175,032)	
Written back on disposal	—	—	—	2,295	—	2,295	
As at December 31 , 2006	<u>(22,466)</u>	<u>(136,557)</u>	<u>(1,987,080)</u>	<u>(36,625)</u>	<u>(563)</u>	<u>(2,183,291)</u>	
Carrying amount:							
As at December 31 , 2006	<u>514,575</u>	<u>1,111,398</u>	<u>12,888,028</u>	<u>49,156</u>	<u>3,287</u>	<u>14,566,444</u>	
As at December 31 , 2005 (Unaudited)	<u>526,010</u>	<u>1,184,687</u>	<u>13,955,385</u>	<u>56,036</u>	<u>2,137</u>	<u>15,724,255</u>	

The building certificates of the Company's factory buildings are still in the process of approval.

13 CONSTRUCTION IN PROGRESS

	<u>2005</u> <u>RMB ' 000</u> <i>(Unaudited)</i>	<u>2006</u> <u>RMB ' 000</u>
Cost		
As at January 1	16,162,786	1,671
Additions during the year	1,608,935	28,390
Transferred to intangible assets	(1,114,002)	—
Transferred to fixed assets	<u>(16,656,048)</u>	<u>(2,034)</u>
As at December 31	<u>1,671</u>	<u>28,027</u>

14 INTANGIBLE ASSETS

	<u>Land use</u> <u>right</u> <u>RMB ' 000</u>	<u>Patent</u> <u>RMB ' 000</u>	<u>Computer</u> <u>software</u> <u>RMB ' 000</u>	<u>Total</u> <u>RMB ' 000</u>
Cost				
As at January 1, 2005 (Unaudited)	—	—	9,724	9,724
Additions during the year	—	—	10,775	10,775
Transfer from construction in progress	<u>233,926</u>	<u>880,076</u>	—	<u>1,114,002</u>
As at December 31, 2005 (Unaudited)	<u>233,926</u>	<u>880,076</u>	<u>20,499</u>	<u>1,134,501</u>
Accumulated amortization As at				
January 1, 2005 (Unaudited)	—	—	(2,394)	(2,394)
Charge for the year	<u>(4,162)</u>	<u>(74,454)</u>	<u>(3,528)</u>	<u>(82,144)</u>
As at December 31, 2005 (Unaudited)	<u>(4,162)</u>	<u>(74,454)</u>	<u>(5,922)</u>	<u>(84,538)</u>
Net book value				
As at December 31, 2005 (Unaudited)	<u>229,764</u>	<u>805,622</u>	<u>14,577</u>	<u>1,049,963</u>
As at January 1, 2005 (Unaudited)	—	—	7,330	7,330

	<u>Land use right</u> RMB' 000	<u>Patent</u> RMB' 000	<u>Computer software</u> RMB' 000	<u>Total</u> RMB' 000
Cost				
As at January 1, 2006	233,926	880,076	20,499	1,134,501
Additions during the year	—	—	2,915	2,915
As at December 31, 2006	<u>233,926</u>	<u>880,076</u>	<u>23,414</u>	<u>1,137,416</u>
Accumulated amortization				
As at January 1, 2006	(4,162)	(74,454)	(5,922)	(84,538)
Charge for the year	<u>(4,995)</u>	<u>(88,007)</u>	<u>(4,355)</u>	<u>(97,357)</u>
As at December 31, 2006	<u>(9,157)</u>	<u>(162,461)</u>	<u>(10,277)</u>	<u>(181,895)</u>
Carrying amount				
As at December 31, 2006	<u>224,769</u>	<u>717,615</u>	<u>13,137</u>	<u>955,521</u>
As at December 31, 2005 (Unaudited)	<u>229,764</u>	<u>805,622</u>	<u>14,577</u>	<u>1,049,963</u>

The Company obtained land use rights through purchase from third parties.

15 LONG-TERM DEFERRED EXPENSES

	<u>2005</u> RMB' 000 (Unaudited)
As at January 1, 2005	422,143,483
Additions during the year	120,507,984
Decrease during the year- amortization	(542,651,467)
As at December 31, 2005	<u>—</u>

Long-term deferred expenses in 2005 represented pre-operating expenses, which was fully charged to income statement in the month of commencement of operations.

	<u>2006</u> RMB' 000
As at January 1, 2006	—
Additions during the year	41,906
Decrease during the year- amortization	(4,633)
As at December 31, 2006	<u>37,273</u>

Long-term deferred expenses in 2006 represented catalysts, which were amortized on a straight-line basis over their beneficial periods.

16 DEFERRED TAX ASSETS

	<u>2005</u> <u>RMB ' 000</u> (Unaudited)	<u>2006</u> <u>RMB ' 000</u>
Resulting from:		
Pre-operating expenditures (Note 4)	<u>—</u>	<u>17,636</u>

According to the relevant tax regulations, pre-operating expenditures should be amortized in five years for the deduction of taxable income. A deferred tax asset resulting from this timing difference was recognized, as management expected that there would be sufficient taxable income during the period of its reversal.

17 OTHER PAYABLES

The Company's other payables at December 31, 2005 and 2006 are as follows:

	<u>2005</u> <u>RMB ' 000</u> (Unaudited)	<u>2006</u> <u>RMB ' 000</u>
Payables for construction services	945,148	397,147
Others	<u>60,053</u>	<u>60,006</u>
	<u>1,005,201</u>	<u>457,153</u>

18 LONG-TERM LIABILITIES DUE WITHIN ONE YEAR

	2005		2006			
	<i>Principal in foreign currency ' 000</i>	<i>RMB/RMB equivalent RMB ' 000</i>	<i>Principal in foreign currency ' 000</i>	<i>RMB/RMB equivalent RMB ' 000</i>	<i>Interest rate (p.a.)</i>	<i>Guaranteed</i>
	<i>(Unaudited)</i>	<i>(Unaudited)</i>				
Bank loans:						
- RMB						by BP International and Sinopec
		—		150,975	5.66%	
- USD						by BP International and Sinopec
	—	—	41,850	326,794	LIBOR+ 0.7%	
Total		—		477,769		

19 LONG-TERM LOANS

The Company's long-term loans at December 31 are as follows:

	2005				2006			
	<i>Principal in foreign currency ' 000</i>	<i>RMB/ RMB equivalent RMB ' 000</i>	<i>Interest rate (p.a.)</i>	<i>Guaranteed</i>	<i>Principal in foreign currency ' 000</i>	<i>RMB/ RMB equivalent RMB ' 000</i>	<i>Interest rate (p.a.)</i>	<i>Guaranteed</i>
	<i>(Unaudited)</i>	<i>(Unaudited)</i>						
Bank loans:								
- RMB								by BP International and Sinopec
		5,810,000	5.184%			5,490,000	5.66%	
- USD								by BP International and Sinopec
	620,000	5,003,524	LIBOR+ 0.7%		620,000	4,841,394	LIBOR+ 0.7%	
Total long-term bank loans outstanding		10,813,524				10,331,394		
Less:								
Amounts due within one year (Note 18)		—				477,769		
Total		10,813,524				9,853,625		

According to the bank syndicated loan contract led by Bank of China, the Renminbi loans are repayable in 29 semi-annual instalments commencing December 20, 2007 through December 20, 2021.

The US dollar loans are repayable in 13 semi-annual instalments commencing December 20, 2007 through December 20, 2013.

The Company made an early repayment of RMB 320,000,000 on December 22, 2006.

20 PAID-IN CAPITAL

Registered capital

	<i>2005 (Unaudited) and 2006</i>	
	<i>Amount USD ' 000</i>	<i>%</i>
BPCECIL	450,720	50%
Sinopec	270,432	30%
SPC	180,288	20%
	<u>901,440</u>	<u>100%</u>

Paid-in capital

	<i>2005</i>			<i>2006</i>		
	<i>Amount in USD ' 000</i>	<i>Amount in RMB ' 000 equivalent</i>	<i>%</i>	<i>Amount in USD ' 000</i>	<i>Amount in RMB ' 000 equivalent</i>	<i>%</i>
BPCECIL	407,608	3,373,703	48%	450,720	3,721,792	50%
Sinopec		2,233,076	31%		2,233,076	30%
SPC		1,488,717	21%		1,488,717	20%
		<u>7,095,496</u>	<u>100%</u>		<u>7,443,585</u>	<u>100%</u>

21 CAPITAL RESERVE

	<i>2005 RMB ' 000</i>	<i>2006 RMB ' 000</i>
Foreign currency capital translation differences	<u>(14)</u>	<u>(509)</u>

22 SURPLUS RESERVE

	<i>General reserve fund RMB ' 000</i>	<i>Enterprise expansion fund RMB ' 000</i>	<i>Total RMB ' 000</i>
Profit appropriation in 2006	<u>19,697</u>	<u>19,696</u>	<u>39,393</u>

23 PROFIT APPROPRIATION

Appropriation to various funds

In accordance with the Board of Directors resolution on November 27, 2006, the Company made appropriations to the following funds:

Surplus reserve - Enterprise expansion fund	1%
Surplus reserve - General reserve fund	1%
Staff and workers' bonus and welfare fund	1%

24 SALES FROM PRINCIPAL ACTIVITIES

	<i>2004</i>	<i>2005</i>	<i>2006</i>
	<i>RMB' 000</i>	<i>RMB' 000</i>	<i>RMB' 000</i>
	<i>(Unaudited)</i>	<i>(Unaudited)</i>	
Sales of goods	165,368	12,616,859	21,657,400
Rendering of services	—	73,338	119,997
	<u>165,368</u>	<u>12,690,197</u>	<u>21,777,397</u>

25 FINANCIAL EXPENSES

	<i>2004</i>	<i>2005</i>	<i>2006</i>
	<i>RMB' 000</i>	<i>RMB' 000</i>	<i>RMB' 000</i>
	<i>(Unaudited)</i>	<i>(Unaudited)</i>	
Interest expense incurred	280,728	478,793	617,916
Less: Borrowing costs capitalised	<u>(280,728)</u>	<u>(71,339)</u>	—
Net interest expense	—	407,454	617,916
Less: Interest income	—	(4,733)	(34,875)
Net exchange gain	—	(125,159)	(157,429)
Other financial expenses/(income)	—	6,656	(1,652)
Total	<u>—</u>	<u>284,218</u>	<u>423,960</u>

26 SUBSIDY INCOME

Subsidy income is substantially comprised of electricity price subsidies granted by Shanghai Chemical Industry Park.

27 RELATED PARTY TRANSACTIONS

(a) Related parties with controlling relationships

	<u>Registered address</u>	<u>Principal activities</u>	<u>Relationship with the Company</u>	<u>Types of legal entity</u>
Sinopec	Beijing, the PRC	Oil and gas exploration, development, production and marketing, crude oil processing, oil products trading and distribution	Chinese investor	Corporation Limited by Shares
SPC	Shanghai, the PRC	Crude oil processing, petroleum products, synthetic resins and plastics products, synthetic fibre raw materials and synthetic fibres	Chinese investor	Corporation Limited by Shares
BPCECIL	Wales, the UK	Investment	Foreign investor	Limited Liability Company

(b) Relationship between the Company and related parties without controlling relationships

<u>Name of related parties</u>	<u>Relationship with the Company</u>
Sinopec International Co., Ltd. (“Sinopec International”)	A fellow subsidiary of Sinopec
Sinopec Zhenhai Refining & Chemical Co., Ltd. (“Sinopec Zhenhai”)	A fellow subsidiary of Sinopec
Sinopec International Industry Co., Ltd. (“Sinopec International Industry”)	A fellow subsidiary of Sinopec
Zhejiang Jingyong Acrylic Co., Ltd. (“Jingyong Acrylic”)	A fellow subsidiary of Sinopec
China International United Petroleum & Chemicals Co., Ltd. (“CIUPC”)	A fellow subsidiary of Sinopec
Sinopec Shanghai Gaoqiao Branch (“Sinopec Gaoqiao Branch”)	A branch of Sinopec
Sinopec Maoming Branch	A branch of Sinopec
Sinopec Guangzhou Branch	A branch of Sinopec
Sinopec Jinling Branch (“Sinopec Jinling Branch”)	A branch of Sinopec
Sinopec Sales Company Shanghai Branch (“SSCS”)	A branch of Sinopec
China Jinshan Associated Trading Corporation (“JAT”)	A fellow subsidiary of SPC
Shanghai Jindi Petroleum & Chemicals Co., Ltd. (“Shanghai Jindi”)	A fellow subsidiary of SPC

Shanghai Jinhua Industry Co., Ltd.
(“Jinhua Industry”)
BP Singapore Pte Limited (“BP
Singapore”)
O&D Trading Limited

A fellow subsidiary of SPC
A fellow subsidiary of BPCECIL
A fellow subsidiary of BPCECIL

(c) The amounts of the Company's related party transactions during the year and its balances with related parties at the year end are summarised as follows:

i) The material related party transactions of the Company are summarised as follows:

Purchase of construction services

	<u>2004</u> <u>RMB' 000</u> <u>(Unaudited)</u>	<u>2005</u> <u>RMB' 000</u> <u>(Unaudited)</u>	<u>2006</u> <u>RMB'</u> <u>000</u>
Sinopec International	439,562	109,803	3,717
Other fellow subsidiaries of Sinopec, SPC	56,791	35,086	1,466
SPC	—	64,325	58
JAT	<u>92,529</u>	<u>15,214</u>	<u>11,141</u>
	<u>588,882</u>	<u>224,428</u>	<u>16,382</u>

Purchase of goods

	<u>2004</u> <u>RMB' 000</u> <u>(Unaudited)</u>	<u>2005</u> <u>RMB' 000</u> <u>(Unaudited)</u>	<u>2006</u> <u>RMB' 000</u>
Sinopec International	153,885	81,925	—
Sinopec Gaoqiao Branch	—	3,429,090	4,876,223
Sinopec Maoming Branch	—	—	832,050
Sinopec Guangzhou Branch	—	—	210,391
Sinopec Zhenhai	—	4,070,950	6,871,035
SPC	115,567	741,596	706,459
CIUPC	—	444,842	—
Sinopec Jinling Branch	—	259,798	—
JAT	—	62,800	17,223
Shanghai Jindi	—	75,780	344,334
Other fellow subsidiaries of Sinopec, SPC	8,235	10,432	16,282
O&D Trading Limited	—	19,621	—
BP Singapore	<u>36,152</u>	<u>711,627</u>	<u>92,268</u>
	<u>313,839</u>	<u>9,908,461</u>	<u>13,966,265</u>

Sales of goods

	2004 <u>RMB ' 000</u> <i>(Unaudited)</i>	2005 <u>RMB ' 000</u> <i>(Unaudited)</i>	2006 <u>RMB ' 000</u>
Sinopec International Industry	—	70,046	92,360
Sinopec International	—	—	59,352
Sinopec Gaoqiao Branch	—	433,045	926,397
SSCS	—	24,389	8,996
SPC	—	472,191	909,854
JAT	—	253,896	706,042
Jingyong Acrylic	—	516,808	723,803
Jinhua Industry	—	—	307
BP Singapore	—	64,996	50,361
	<u>—</u>	<u>1,835,371</u>	<u>3,477,472</u>

The Board of Directors of the Company is of the opinion that the above transactions were carried out in the normal course of business and on normal commercial terms.

- ii) The balances of related party receivables and payables are summarised as follows:

	<i>2005 (Unaudited)</i>					
	<u>Payment in advance</u>	<u>Other receivables</u>	<u>Accounts payable</u>	<u>Other payables</u>	<u>Received in advance</u>	<u>Accounts receivable</u>
	<u>RMB ' 000</u>	<u>RMB ' 000</u>	<u>RMB ' 000</u>	<u>RMB ' 000</u>	<u>RMB ' 000</u>	<u>RMB ' 000</u>
Sinopec International	—	—	—	8,213	—	—
Sinopec Zhenhai	—	—	179,029	—	—	—
Sinopec Gaoqiao Branch	—	—	198,476	—	—	42,821
SPC	614	—	26,255	9,563	—	26,272
Jingyong Acrylic	—	—	—	—	—	50,306
JAT	—	—	4,761	—	—	24,576
Other fellow subsidiaries of Sinopec SPC	—	4	3,797	700	16,664	—
BP Singapore Pte. Ltd.	—	—	100	—	—	14,044
	<u>614</u>	<u>4</u>	<u>412,418</u>	<u>18,476</u>	<u>16,664</u>	<u>158,019</u>

	<i>2006</i>					
	<u>Payment in advance</u>	<u>Other receivables</u>	<u>Accounts payable</u>	<u>Other payables</u>	<u>Received in advance</u>	<u>Accounts receivable</u>
	<u>RMB ' 000</u>	<u>RMB ' 000</u>	<u>RMB ' 000</u>	<u>RMB ' 000</u>	<u>RMB ' 000</u>	<u>RMB ' 000</u>
Sinopec International	—	537	—	1,975	2,074	—

Sinopec						
Zhenhai	—	—	366,116	—	—	—
Sinopec						
Gaoqiao						
Branch	—	—	229,365	—	—	52,275
SPC	—	—	506	—	—	52,630
Jingyong						
Acrylic	—	—	—	—	—	32,034
JAT	650	—	2,800	—	—	46,143
Other fellow						
subsidiaries						
of Sinopec						
SPC	—	—	3,297	701	—	—
	<u>650</u>	<u>537</u>	<u>602,084</u>	<u>2,676</u>	<u>2,074</u>	<u>183,082</u>

28 COMMITMENTS

(a) Capital commitments

As at December 31, capital commitments of the Company are summarised as follows:

	<u>2005</u> <u>RMB ' 000</u> <i>(Unaudited)</i>	<u>2006</u> <u>RMB ' 000</u>
Contracted for	—	15,925
Authorized but not contracted for	—	3,514
	<u>—</u>	<u>19,439</u>

(b) Operating lease commitments

As at December 31, 2006, the future minimum lease payments under non-cancellable operating leases were payable as follows:

	<u>2005</u> <u>RMB ' 000</u> <i>(Unaudited)</i>	<u>2006</u> <u>RMB ' 000</u>
Within 1 year	16,127	10,510
After 1 year but within 2 years	261	—
Total	<u>16,388</u>	<u>10,510</u>

29 SIGNIFICANT DIFFERENCES BETWEEN FINANCIAL STATEMENTS PREPARED UNDER PRC ACCOUNTING RULES AND REGULATIONS AND ACCOUNTING PRINCIPLES GENERALLY ACCEPTED IN THE UNITED STATES OF AMERICA

The Company's accounting policies conform with PRC Accounting Rules and Regulations which differ in certain significant respects from accounting principles generally accepted in the United States of America ("U.S. GAAP"). Information relating to the nature of such differences is presented below.

(a) Pre-operating expenditure

Under PRC Accounting Rules and Regulations, all expenses incurred during the start-up period are aggregated in long-term deferred expenses and then fully charged to the income statement in the month of commencement of operations.

Under U.S. GAAP, such expenditures for start-up activities generally should be expensed as they are incurred.

(b) Staff and workers' bonus and welfare fund

Under PRC Accounting Rules and Regulations, staff and workers' bonus and welfare fund should be treated as profit appropriation.

Under U.S. GAAP, staff and workers' bonus and welfare fund is recognized as an expense in the income statement.

(c) Foreign currency transaction exchange gains and losses

Under PRC Accounting Rules and regulations, foreign currency exchange differences on funds borrowed for construction are capitalized as property, plant and equipment to the extent that they are regarded as an adjustment to interest costs during the construction period.

Under U.S. GAAP, such foreign currency transaction exchange gains and losses are included in current earnings.

(d) Deferred income taxes

Under PRC Accounting Rules and Regulations, under the tax effect accounting method, a deferred tax debit resulting from timing differences should be recognized and presented as a deferred tax debit only if there will be sufficient taxable income during the period of their reversal.

Under U.S. GAAP, deferred income taxes are generally recognized for all temporary differences that exist between the carrying amounts of all assets and liabilities and their respective tax bases amounts. A valuation allowance is recognized to the extent it is more likely than not a deferred tax asset will not be realized.

(e) Land use rights

Under PRC Accounting Rules and Regulations, land use rights are classified under "intangible assets" until the development work commences. The acquisition costs are amortised over their expected useful lives, starting from the month in which the land use rights are acquired. If the land use rights are used for constructing properties for the entity's own use, the land use rights are transferred to "construction in progress" at their carry amount as soon as the construction work commences. When the properties reach a condition where they are ready for their intended use, the total costs of the properties are transferred to "fixed assets" and depreciated over their expected remaining useful lives.

Under U.S. GAAP, the costs of such land use rights are considered to be prepaid expenses and are generally classified under "Lease prepayment" in the balance sheet. Such prepaid land use rights are generally charged to expense in the income statements on a straight line basis over the term of the land use right.

(f) Presentation of financing expenses

Under PRC Accounting Rules and Regulations, financing expenses are included in the calculation of “Operating profit”.

Under U.S. GAAP, such financing expenses generally are excluded from “Operating Profit”.

Exhibit Index

<u>No.</u>	<u>Exhibit</u>
12.1	Certification of Chairman Required by Rule 13a-14(a).
12.2	Certification of Chief Financial Officer Required by Rule 13a-14(a).
13.1	Certification of Chairman Required by Rule 13a-14(b) and Section 1350 of Chapter 63 of Title 18 of the United States Code.
13.2	Certification of Chief Financial Officer Required by Rule 13a-14(b) and Section 1350 of Chapter 63 of Title 18 of the United States Code.